



TENSIONER DEVICES

Optimum tension for chain and belt drives

- Quiet and smooth running
- Best possible transfer of power
- Automatic re-tensioning
- Compensation for belt elongation
- Pressing, guiding and vibration damping

Product advantages:

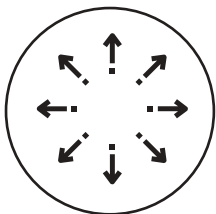

wide range
of applications

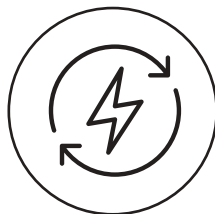

energy-saving



minimal
maintenance costs

Selection table tensioner devices

	Illustration	Type	Description	Page
Standard tensioner devices		SE	Standard component. Housing and inner part made out of steel. Rubber quality Rubmix 10. Steel parts ROSTA blue painted. Working temperature: - 40 ° to + 80 °C.	5.3
		SE-G	Oil resistant. Housing and inner part made out of steel. Rubber quality Rubmix 20. Steel parts galvanized. Marked with yellow dot. Working temperature: - 30 ° to + 90 °C.	
		SE-W	Heat resistant. Housing and inner part made out of steel. Rubber quality Rubmix 40. Steel parts ROSTA blue painted. Marked with red dot. Tension force 40% less than SE. Working temperature: - 35 ° to + 120 °C max.	
Additional tensioner devices		SE-R	Reinforced lever arm. Housing and inner part made out of steel. Rubber quality Rubmix 10. Arm and inner core especially welded for use on combustion engines and compressors. Steel parts ROSTA blue painted. Marked with white ring. Working temperature: - 40 ° to + 80 °C.	5.3
		SE-I	Housing and inner part made out of stainless steel. Rubber quality Rubmix 10. For the use in food- and pharmaceutical industries. Material: GX5CrNi19-10. Working temperature: - 40 ° to + 80 °C.	5.4
		SE-B	Boomerang®. Housing and inner part made out of steel. Rubber quality Rubmix 10. For the tensioning of very long chain and belt drives (triple compensation). Steel parts ROSTA blue painted. Working temperature: - 40 ° to + 80 °C.	5.5
		SE-F	Front mounting device. Housing and inner part made out of steel. Rubber quality Rubmix 10. As example for installations on blind-hole frames (fixation from the front only). Steel parts ROSTA blue painted. Hex socket screw quality 12.9. Working temperature: - 40 ° to + 80 °C.	5.6
		SE-FE	Front mounting. For installations on blind-hole frames (fixation from the front only). Steel parts painted black. Hex socket screw quality 12.9. Especially designed for engine applications. Working temperature: see page 5.7.	5.7

Note about accessories on pages 5.8–5.15.

Tensioner Device

SE/SE-G/SE-W/SE-R

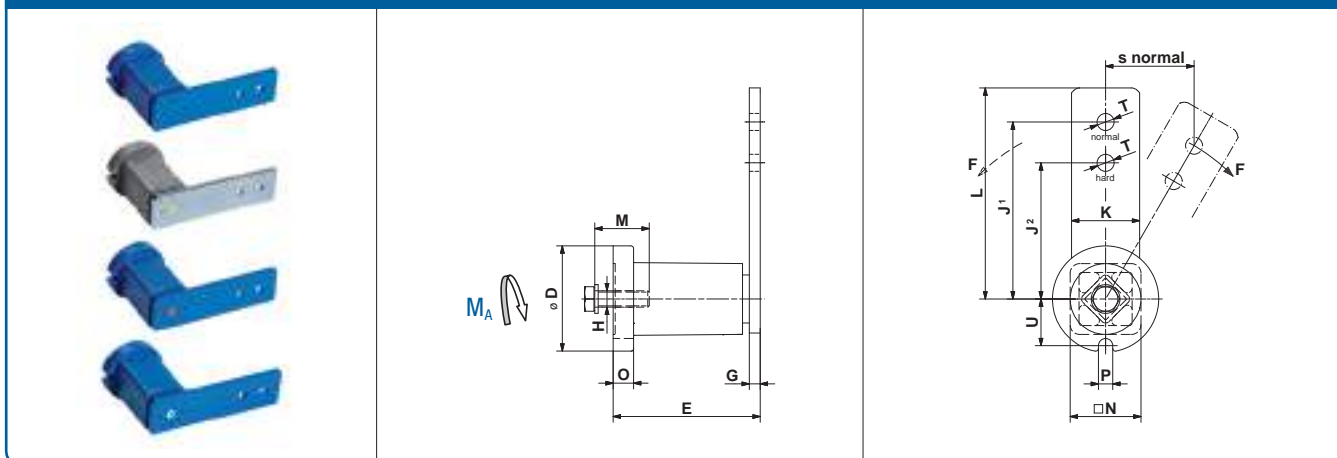

Part no.	Type	D	E	G	H	J ¹	J ²	K	L	M	N	O	P	T	U	Weight [kg]
06 011 001	SE 11	35	51 ⁺¹ _{-0.5}	5	M6	80	60	20	90	20	22	6	8	8.5	16.5	0.2
06 013 201	SE 11-G	35	51 ⁺¹ _{-0.5}	5	M6	80	60	20	90	20	22	6	8	8.5	16.5	0.2
06 011 002	SE 15	45	64 ⁺¹ _{-0.5}	5	M8	100	80	25	112.5	25	30	8	8.5	10.5	20.8	0.4
06 013 202	SE 15-G	45	64 ⁺¹ _{-0.5}	5	M8	100	80	25	112.5	25	30	8	8.5	10.5	20.8	0.4
06 015 002	SE 15-W	45	64 ⁺¹ _{-0.5}	5	M8	100	80	25	112.5	25	30	8	8.5	10.5	20.8	0.4
06 011 702	SE-R 15	45	64 ⁺¹ _{-0.5}	5	M8	100	80	25	112.5	25	30	8	8.5	10.5	20.8	0.4
06 011 003	SE 18	58	79 ⁺¹ _{-0.5}	7	M10	100	80	30	115	30	35	10.5	8.5	10.5	25.3	0.7
06 013 203	SE 18-G	58	79 ⁺¹ _{-0.5}	7	M10	100	80	30	115	30	35	10.5	8.5	10.5	25.3	0.7
06 015 003	SE 18-W	58	79 ⁺¹ _{-0.5}	7	M10	100	80	30	115	30	35	10.5	8.5	10.5	25.3	0.7
06 011 703	SE-R 18	58	79 ^{+1.5} _{-0.5}	7	M10	100	80	30	115	30	35	10.5	8.5	10.5	25.3	0.7
06 011 004	SE 27	78	108 ^{+1.5} _{-0.5}	8	M12	130	100	50	155	40	52	15	10.5	12.5	34.3	1.8
06 013 204	SE 27-G	78	108 ^{+1.5} _{-0.5}	8	M12	130	100	50	155	40	52	15	10.5	12.5	34.3	1.9
06 015 004	SE 27-W	78	108 ^{+1.5} _{-0.5}	8	M12	130	100	50	155	40	52	15	10.5	12.5	34.3	1.8
06 011 005	SE 38	95	140 ⁺² _{-0.5}	10	M16	175	140	60	205	40	66	15	12.5	20.5	42.0	3.3
06 013 205	SE 38-G	95	140 ⁺² _{-0.5}	10	M16	175	140	60	205	40	66	15	12.5	20.5	42.0	3.3
06 015 005	SE 38-W	95	140 ⁺² _{-0.5}	10	M16	175	140	60	205	40	66	15	12.5	20.5	42.0	3.3
06 011 006	SE 45	115	200 ⁺² ₋₁	12	M20	225	180	70	260	50	80	18	12.5	20.5	52.0	6.4
06 013 206	SE 45-G	115	200 ⁺² ₋₁	12	M20	225	180	70	260	50	80	18	12.5	20.5	52.0	6.5
06 015 006	SE 45-W	115	200 ⁺² ₋₁	12	M20	225	180	70	260	50	80	18	12.5	20.5	52.0	6.4
06 011 007	SE 50	130	210 ⁺³ ₋₁	20	M24	250	200	80	290	60	87	20	17	20.5	57.5	10.4
06 013 207	SE 50-G	130	210 ⁺³ ₋₁	20	M24	250	200	80	290	60	87	20	17	20.5	57.5	10.3
06 015 007	SE 50-W	130	210 ⁺³ ₋₁	20	M24	250	200	80	290	60	87	20	17	20.5	57.5	10.3

Further product and performance data in chapter 7 «Technology».

SE-R: Tensioning element with strengthened tensioning arm

If no other units are specified, the numbers given are in mm.

Tensioner Device

SE-I

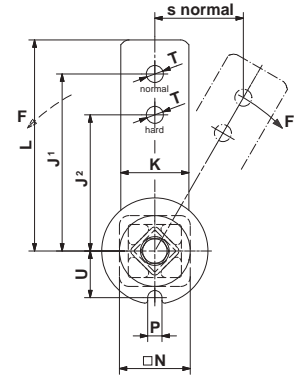
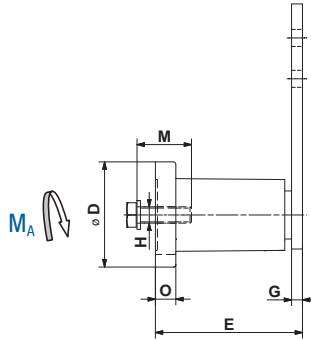

Part no.	Type	D	E	G	H	J ¹	J ²	K	L	M	N	O	P	T	U	Weight [kg]
06 071 111	SE-I 15	45	64 ⁺¹ _{-0.5}	5	M8	100	80	25	112.5	25	30	8	8.5	10.5	20.8	0.4
06 071 112	SE-I 18	58	79 ^{+1.5} _{-0.5}	7	M10	100	80	30	115	30	35	10.5	8.5	10.5	25.3	0.8
06 071 113	SE-I 27	78	108 ⁺² _{-0.5}	8	M12	130	100	50	155	40	52	15	10.5	12.5	34.3	2.3
06 071 114	SE-I 38	95	140 ⁺² _{-0.5}	10	M16	175	140	60	205	40	66	15	12.5	20.5	42.0	4.1

Further product and performance data in chapter 7 «Technology».

Tensioning element made out of stainless steel, INOX

If no other units are specified, the numbers given are in mm.

Tensioner Device

SE-B Boomerang®

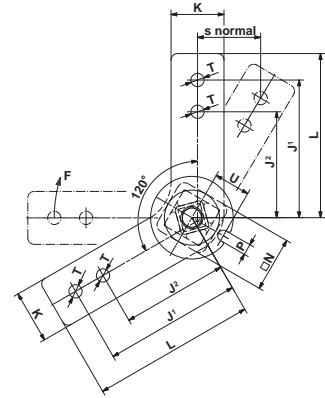
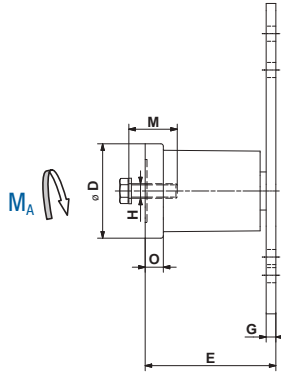

Part no.	Type	D	E	G	H	J ¹	J ²	K	L	M	N	O	P	T	U	Weight [kg]
06 021 003	SE-B 18	58	78 ^{+1.5} _{-0.5}	6	M10	100	80	30	115	30	35	10.5	8.5	10.5	25.3	0.8
06 021 004	SE-B 27	78	108 ⁺² _{-0.5}	8	M12	130	100	50	155	40	52	15	10.5	12.5	34.3	2.2

Further product and performance data in chapter 7 «Technology».
If no other units are specified, the numbers given are in mm.

Tensioner Device

SE-F

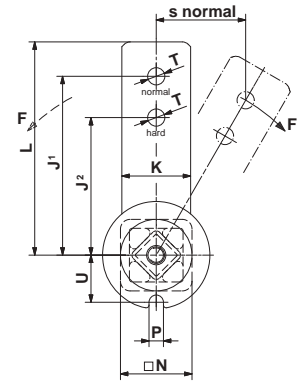
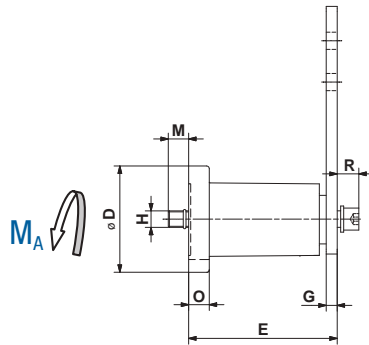

Part no.	Type	D	E	G	H	J ¹	J ²	K	L	M	N	O	P	R	T	U	Weight [kg]
06 061 002	SE-F 15	45	64 ⁺¹ _{-0.5}	5	M6	100	80	25	112.5	12	30	8	8.5	10	10.5	20.8	0.4
06 061 003	SE-F 18	58	79 ^{+1.5} _{-0.5}	7	M8	100	80	30	115	18	35	10.5	8.5	11	10.5	25.3	0.7
06 061 004	SE-F 27	78	108 ⁺² _{-0.5}	8	M10	130	100	50	155	17	52	15	10.5	15	12.5	34.3	1.9
06 061 005	SE-F 38	95	140 ⁺² _{-0.5}	10	M12	175	140	60	205	16	66	15	12.5	17	20.5	42.0	3.5
06 061 006	SE-F 45	115	200 ⁺³ ₋₁	12	M16	225	180	70	260	32	80	18	12.5	24	20.5	52.0	7.2
06 061 007	SE-F 50	130	210 ⁺³ ₋₁	20	M20	250	200	80	290	23	87	20	17	27	20.5	57.5	11.6

Further product and performance data in chapter 7 «Technology».

Tensioning element with front mounting.

Screw quality 12.9

If no other units are specified, the numbers given are in mm.

Tensioner Device

SE-FE

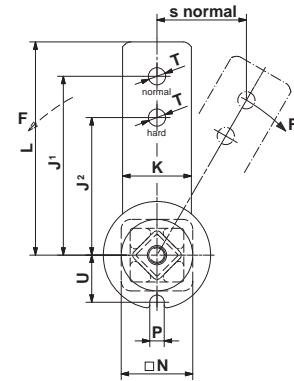
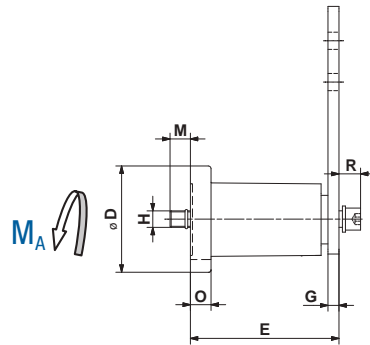

Part no.	Type	D	E	G	H	J ¹	J ²	K	L	M	N	O	P	R	T	U	Weight [kg]
06 093 904	SE-FE 27	78	110 ⁺² _{-0.5}	10	M10	130	100	50	155	16	52	15	10.5	15	12.5	34.3	2.1
06 095 905	SE-FE 38	95	120 ⁺² _{-0.5}	10	M12	145	110	60	175	35	66	15	12.5	17	22.0	42.0	3.1

Part no.	Type	Rubber type	Working temperature	Marked with	Pre-tension $\leq 10^\circ$ (J ¹)		Pre-tension $\leq 20^\circ$ (J ¹)		Pre-tension $\leq 30^\circ$ (J ¹)		Coating
					F [N]	s [mm]	F [N]	s [mm]	F [N]	s [mm]	
06 093 904	SE-FE 27	Rubmix 20	-30° to +90°C	yellow dot	150	23	380	44	810	65	RAL 9005 (black)
06 095 905	SE-FE 38	Rubmix 40	-35° to +120°C	red dot	170	25	425	50	870	73	RAL 9005 (black)

Further product and performance data in chapter 7 «Technology».

Tensioning element with front mounting in special design.

Screw quality 12.9

If no other units are specified, the numbers given are in mm.

Tensioner Device

Sprocket wheel set N

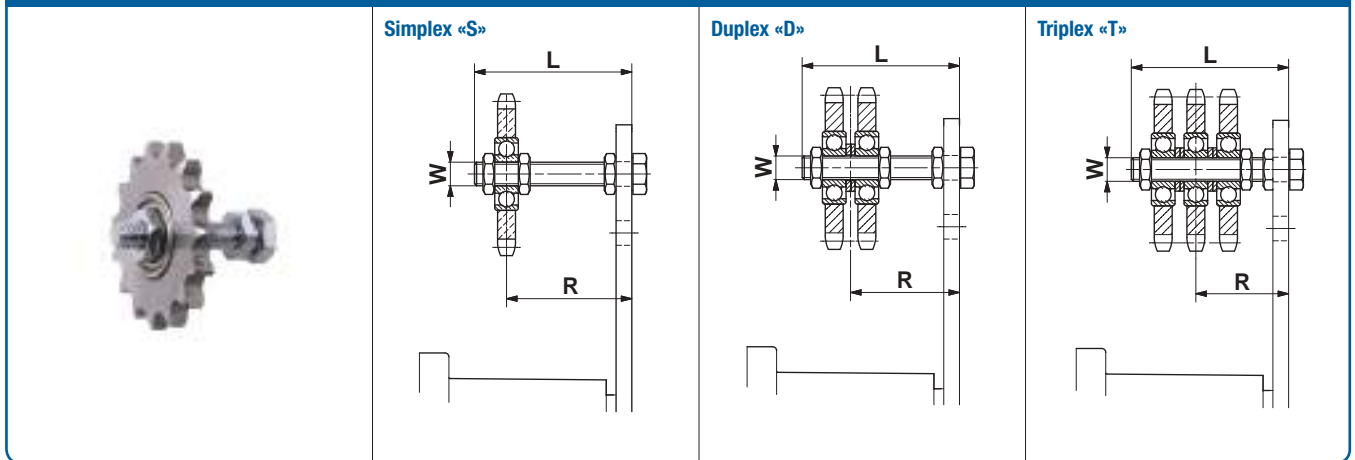

Part no.	Type	Roller chain		Number of teeth	W	L	Torque hex nut 0.5 d [Nm]	suitable for size SE	Adjusting range R with SE	Weight [kg]
		ANSI	DIN 8187							
Simplex «S»										
06 510 001	N $\frac{3}{8}$ " – 10 S	35	ISO 06 B-1	15	M10	55	20	15/18	22–43/23–43	0.15
06 510 002	N $\frac{1}{2}$ " – 10 S	40	ISO 08 B-1	15	M10	55	20	18	23–44	0.20
06 510 003	N $\frac{5}{8}$ " – 12 S	50	ISO 10 B-1	15	M12	80	35	27	27–65	0.35
06 510 004	N $\frac{3}{4}$ " – 12 S	60	ISO 12 B-1	15	M12	80	35	27	27–65	0.55
06 510 005	N $\frac{3}{4}$ " – 20 S	60	ISO 12 B-1	15	M20	100	165	38	40–80	0.85
06 510 006	N1" – 20 S	80	ISO 16 B-1	13	M20	100	165	38	40–80	1.25
06 510 007	N1 $\frac{1}{4}$ " – 20 S	100	ISO 20 B-1	13	M20	100	165	45/50	40–80/48–80	2.00
06 510 008	N1 $\frac{1}{2}$ " – 20 S	120	ISO 24 B-1	11	M20	140	165	45/50	40–120/48–120	2.35
Duplex «D»										
06 520 001	N $\frac{3}{8}$ " – 10 D	35	ISO 06 B-2	15	M10	55	20	15/18	27–39/28–39	2.00
06 520 002	N $\frac{1}{2}$ " – 10 D	40	ISO 08 B-2	15	M10	55	20	18	30–37	0.35
06 520 003	N $\frac{5}{8}$ " – 12 D	50	ISO 10 B-2	15	M12	80	35	27	36–57	0.60
06 520 004	N $\frac{3}{4}$ " – 12 D	60	ISO 12 B-2	15	M12	80	35	27	37–56	1.05
06 520 005	N $\frac{3}{4}$ " – 20 D	60	ISO 12 B-2	15	M20	120	165	38	50–90	1.35
06 520 006	N1" – 20 D	80	ISO 16 B-2	13	M20	120	165	38	55–84	2.10
06 520 007	N1 $\frac{1}{4}$ " – 20 D	100	ISO 20 B-2	13	M20	140	165	45/50	60–102/68–102	3.60
06 520 008	N1 $\frac{1}{2}$ " – 20 D	120	ISO 24 B-2	11	M20	140	165	45/50	65–97/73–97	4.25
Triplex «T»										
06 530 001	N $\frac{3}{8}$ " – 10 T	35	ISO 06 B-3	15	M10	70	20	18	33–48	0.25
06 530 002	N $\frac{1}{2}$ " – 12 T	40	ISO 08 B-3	15	M12	80	35	27	41–51	0.50
06 530 003	N $\frac{5}{8}$ " – 12 T	50	ISO 10 B-3	15	M12	80	35	27	43–50	0.95
06 530 004	N $\frac{5}{8}$ " – 20 T	50	ISO 10 B-3	15	M20	120	165	38	56–84	1.25
06 530 005	N $\frac{3}{4}$ " – 20 T	60	ISO 12 B-3	15	M20	120	165	38	59–80	1.50
06 530 006	N1" – 20 T	80	ISO 16 B-3	13	M20	160	165	45	74–108	2.90
06 530 007	N1 $\frac{1}{4}$ " – 20 T	100	ISO 20 B-3	13	M20	160	165	45/50	78–105/86–105	5.20
06 530 008	N1 $\frac{1}{2}$ " – 20 T	120	ISO 24 B-3	11	M20	180	165	45/50	90–111/98–111	6.20

Allows accurate positioning of relevant chain track.
 Ball-bearings 2Z/C3, permanently lubricated.
 Working temperature: –40° bis +100 °C.
 If no other units are specified, the numbers given are in mm.

Tensioner Device

Sprocket wheel N

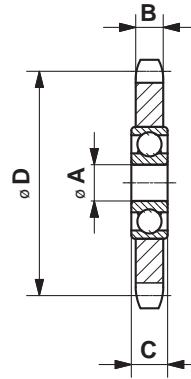

Part no.	Type	Roller chain		Number of teeth	A	B	C	D	Weight [kg]
		ANSI	DIN 8187						
06 500 001	N$\frac{3}{8}$"-10	35	ISO 06 B	15	10	5.3	9	45.81	0.06
06 500 002	N$\frac{1}{2}$"-10	40	ISO 08 B	15	10	7.2	9	61.08	0.15
06 500 003	N$\frac{1}{2}$"-12	40	ISO 08 B	15	12	7.2	12	61.08	0.15
06 500 004	N$\frac{5}{8}$"-12	50	ISO 10 B	15	12	9.1	12	76.36	0.27
06 500 005	N$\frac{5}{8}$"-20	50	ISO 10 B	15	20	9.1	15	76.36	0.29
06 500 006	N$\frac{3}{4}$"-12	60	ISO 12 B	15	12	11.1	12	91.63	0.47
06 500 007	N$\frac{3}{4}$"-20	60	ISO 12 B	15	20	11.1	15	91.63	0.47
06 500 008	N1"-20	80	ISO 16 B	13	20	16.1	15	106.14	0.88
06 500 009	N1$\frac{1}{4}$"-20	100	ISO 20 B	13	20	18.5	15	132.67	1.60
06 500 010	N1$\frac{1}{2}$"-20	120	ISO 24 B	11	20	24.1	15	135.23	1.93

Allows accurate positioning of relevant chain track.

Ball-bearings 2Z/C3, permanently lubricated.

Working temperature: -40° bis $+100^{\circ}\text{C}$.

If no other units are specified, the numbers given are in mm.

Tensioner Device

Chain rider set P

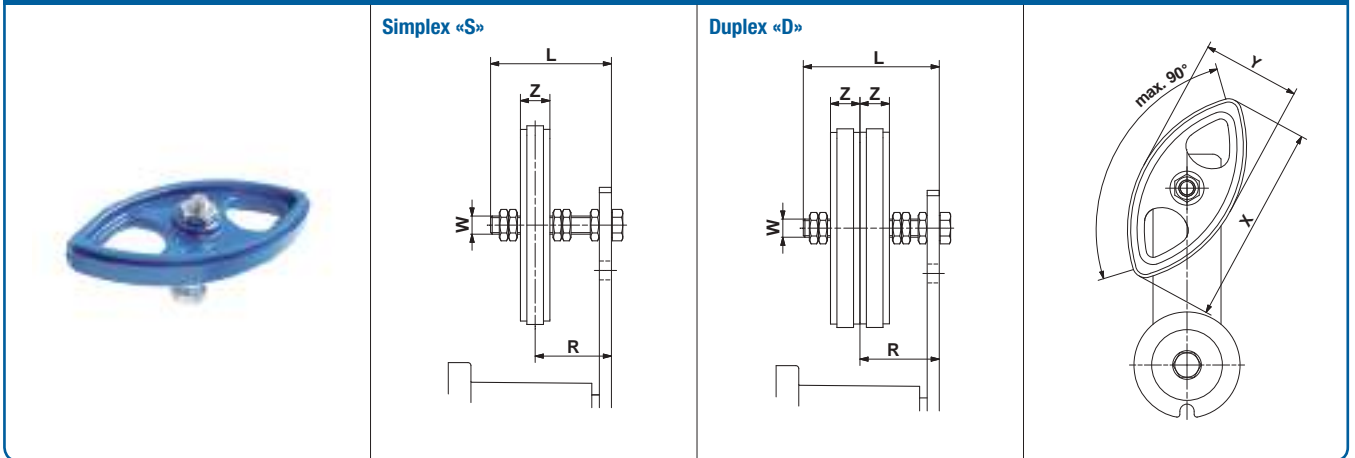

Part no.	Type	Roller chain		W	L	X	Y	Z	Torque hex nut 0.5 d [Nm]	suitable for size SE	Adjusting range R with SE	Weight [kg]
		ANSI	DIN 8187									
Simplex «S»												
06 550 001	P$\frac{3}{8}$"-8 S	35	ISO 06 B-1	M8	45	74	37	10.2	11	11	19-34	0.05
06 550 002	P$\frac{1}{2}$"-10 S	40	ISO 08 B-1	M10	55	96	48	13.9	20	15/18	23-41	0.10
06 550 003	P$\frac{5}{8}$"-10 S	50	ISO 10 B-1	M10	55	126	63	16.6	20	18	24-39	0.12
06 550 004	P$\frac{3}{4}$"-12 S	60	ISO 12 B-1	M12	80	148	72	19.5	35	27	30-61	0.18
Duplex «D»												
06 560 001	P$\frac{3}{8}$"-8 D	35	ISO 06 B-2	M8	45	74	37	10.2	11	11	25-30	0.07
06 560 002	P$\frac{1}{2}$"-10 D	40	ISO 08 B-2	M10	55	96	48	13.9	20	15/18	30-34	0.12
06 560 003	P$\frac{5}{8}$"-10 D	50	ISO 10 B-2	M10	70	126	63	16.6	20	18	34-46	0.17
06 560 004	P$\frac{3}{4}$"-12 D	60	ISO 12 B-2	M12	80	148	72	19.5	35	27	40-52	0.26

For double sided use. Max. allowed chain speed 1.5 m/sec.

Material: POM-H.

Working temperature: -40 ° bis +100 °C.

If no other units are specified, the numbers given are in mm.

Tensioner Device

Chain rider P

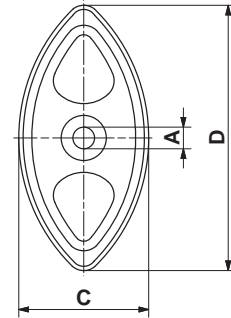

Part no.	Type	Roller chain		A	B	C	D	Weight [kg]
		ANSI	DIN 8187					
06 540 001	P $\frac{3}{8}$ "	35	ISO 06 B	$8^{+0.2}_0$	10.2	37	74	0.02
06 540 002	P $\frac{1}{2}$ "	40	ISO 08 B	$10^{+0.2}_0$	13.9	48	96	0.03
06 540 003	P $\frac{5}{8}$ "	50	ISO 10 B	$10^{+0.2}_0$	16.6	63	126	0.05
06 540 004	P $\frac{3}{4}$ "	60	ISO 12 B	$12^{+0.2}_0$	19.5	72	148	0.07

For double sided use. Max. allowed chain speed 1.5 m/sec.

Material: POM-H.

Working temperature: -40° bis $+100^{\circ}\text{C}$.

If no other units are specified, the numbers given are in mm.

Tensioner Device

Tensioning roller standard R

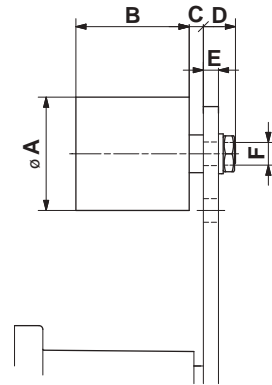

Part no.	Type	Max. speed [rpm]	Max. belt width	A	B	C	D	E	F	Torque hex nut 0.5 d [Nm]	suitable for size SE	Weight [kg]
06 580 001	R 11	8000	30	30	35	2	14	≤5	M8	25	11	0.08
06 580 002	R 15/18	8000	40	40	45	6	16	≤7	M10	20	15/18	0.17
06 580 003	R 27	6000	55	60	60	8	17	≤8	M12	35	27	0.40
06 580 004	R 38	5000	85	80	90	8	25	≤10	M20	165	38	1.15
06 580 005	R 45	4500	130	90	135	10	27	≤12	M20	165	45	1.75

Customer-specific $\varnothing A$ or outer contours on request.

Material: PA 6. Ball-bearings 2Z/C3, permanently lubricated.

Working temperature: -35° bis $+100^{\circ}\text{C}$.

If no other units are specified, the numbers given are in mm.

Tensioner Device

Tensioning roller light RL

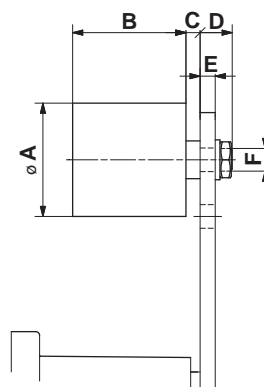

Part no.	Type	Max. speed [rpm]	Max. belt width	A	B	C	D	E	F	Torque hex nut 0.5 d [Nm]	suitable for size SE	Weight [kg]
06 580 901	RL 11	6 000	30	30	35	3	19	≤10	M8	25	11	0.08
06 580 902	RL 15/18	6 000	40	40	45	6	21	≤9	M10	49	15/18	0.17
06 580 903	RL 27	4 500	55	60	60	8	22	≤8	M12	86	27	0.50

Designed for light belt drive loads.

Material: PA 6. Ball-bearings 2Z/C3, permanently lubricated.

Working temperature: -35 ° bis +80 °C.

If no other units are specified, the numbers given are in mm.

Tensioner Device

Bracket WS

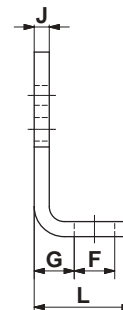
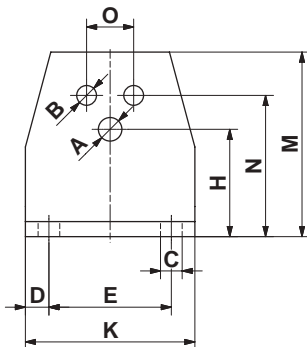

Part no.	Type	A	B	C	D	E	F	G	H	J	K	L	M	N	O	suitable for size SE	Weight [kg]
06 590 001	WS 11	6.5	5.5	7	7.5	30	13	11.5	27	4	45	30	46	35	10	11	0.08
06 590 002	WS 15	8.5	6.5	7	7.5	40	13	13.5	34	5	55	32	58	44	12	15	0.15
06 590 003	WS 18	10.5	8.5	9.5	10	50	15.5	16.5	43	6	70	38	74	55	20	18	0.28
06 590 004	WS 27	12.5	10.5	11.5	12.5	65	21.5	21	57	8	90	52	98	75	25	27	0.70
06 590 005	WS 38	16.5	12.5	14	15	80	24	21	66	8	110	55	116	85	35	38	0.90
06 590 006	WS 45	20.5	12.5	18	20	100	30	26	80	10	140	66	140	110	40	45	1.80

For the easy mounting of tensioners on the standard support (except SE 50).
If no other units are specified, the numbers given are in mm.

Tensioner Device

Safety Sockets

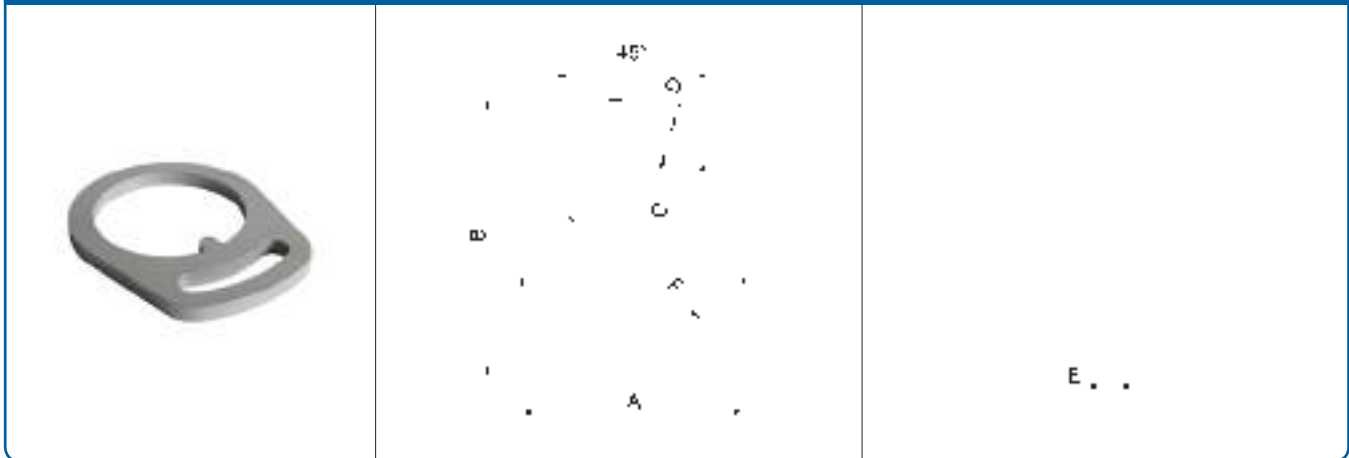

Part no.	Type	A	B	C	D	E	F	suitable for size SE	Weight [kg]
06 618 400	SS 27	104	130	60	13	8	79	27	0.35
06 618 394	SS 38	128	161	75	17	10	96.5	38	0.65

In case of uneven surfaces or coatings that give inadequate frictional locking, additional tensioning can be made with this safety clamp. If no other units are specified, the numbers given are in mm.