



## METRIC DESIGN TAPERED ROLLER BEARINGS

Bore Dia.	Page
15 - 95 mm.....	B142
100 - 220 mm.....	B154
240 - 440 mm.....	B160

## INCH DESIGN TAPERED ROLLER BEARINGS

Bore Dia.	Page
12.000 - 47.625 mm .....	B162
48.412 - 69.850 mm .....	B176
70.000 - 206.375 mm .....	B184

The index for inch design tapered roller bearings is in Appendix 14 (Page C20).

## DOUBLE-ROW TAPERED ROLLER BEARINGS

Bore Dia.	Page
40 - 260 mm.....	B198

**Four-Row Tapered Roller Bearings** are described on pages B322 to B327.

## DESIGN, TYPES AND FEATURES

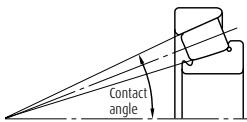

Tapered roller bearings are designed so the apices of the cones formed by the raceways of the cone and cup and the conical rollers all coincide at one point on the axis of the bearing. When a radial load is imposed, an axial force component occurs; therefore, it is necessary to use two bearings in opposition or some other multiple arrangement.

For metric-design medium-angle and steep-angle tapered roller bearings, the respective contact angle symbol C or D is added after the bore number. For normal-angle tapered roller bearings, no contact angle symbol is used.

Medium-angle tapered roller bearings are primarily used for the pinion shafts of differential gears of automobiles.

Among those with high load capacity (HR series), some bearings have the basic number suffixed by J to conform to the specifications of ISO for the cup back face raceway diameter, cup width, and contact angle. Therefore, the cone assembly and cup of bearings with the same basic number suffixed by J are internationally interchangeable.

Among metric-design tapered roller bearings specified by ISO 355, there are those having new dimensions that are different from the dimension series 3XX used in the past. Part of them are listed in the bearing tables. They conform to the specifications of ISO for the smaller end diameter of the cup and contact angle. The cone and cup assemblies are internationally interchangeable. The bearing number formulation, which is different from that for past metric design, is as follows:

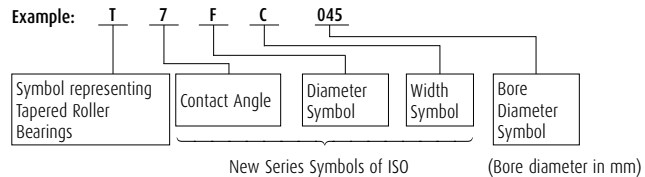

# Tapered Roller Bearings

Besides metric design tapered roller bearings, there are also inch design bearings. For the cone assemblies and cups of inch design bearings, except four-row tapered roller bearings, the bearing numbers are approximately formulated as follows:

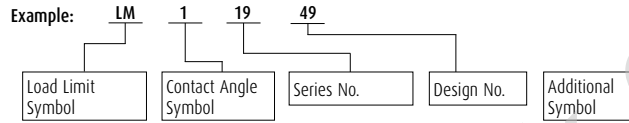

For tapered roller bearings, besides single-row bearings, there are also various combinations of bearings.

The cages of tapered roller bearings are usually pressed steel.

**Table 1 Design and Features of Combinations of Tapered Roller Bearings**

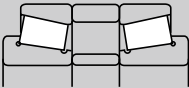
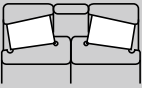
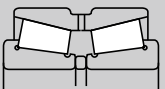
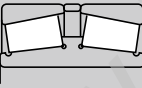
Figure	Arrangement	Examples of Bearing No.	Features
	Back-to-back	HR30210JDB+KLR10	Two standard bearings are combined. The bearing clearance are adjusted by cone spacers or cup spacers. The cones and cups and spacers are marked with serial numbers and mating marks. Components with the same serial number can be assembled referring to the matching symbols.
	Face-to-face	HR30210JDF+KR	
	KBE Type	100KBE31+L	The KBE type is a back-to-back arrangement of bearings with the cup and spacer integrated, and the KH type is a face-to-face arrangement in which the cones are integrated. Since the bearing clearance is adjusted using spacers, it is necessary for components to have the same serial number for assembly with reference to matching symbols.
	KH Type	110KH31+K	

## TOLERANCES AND RUNNING ACCURACY

Metric Design Tapered Roller Bearings

Inch Design Tapered Roller Bearings

Among inch design tapered roller bearings, there are those to which the following precision classes apply. For more details, please consult with NSK.

Table

Pages

8.3 ..... A66 to A69

8.4 ..... A70 and A71

1. J line bearings (in the bearing tables, bearings preceded by ▲)

**Table 2 Tolerances of Cones (CLASS K)**

Units :  $\mu\text{m}$

Nominal Bore Diameter d (mm)		$\Delta_{dmp}$		$V_{dp}$	$V_{dmp}$	$K_{fa}$
over	incl.	high	low	max.	max.	max.
10	18	0	-12	12	9	15
18	30	0	-12	12	9	18
30	50	0	-12	12	9	20
50	80	0	-15	15	11	25
80	120	0	-20	20	15	30
120	180	0	-25	25	19	35
180	250	0	-30	30	23	50
250	315	0	-35	35	26	60
315	400	0	-40	40	30	70

**Table 3 Tolerances of Cups (CLASS K)**

Units :  $\mu\text{m}$

Nominal Outside Diameter D (mm)		$\Delta_{Dmp}$		$V_{Dp}$	$V_{Dmp}$	$K_{ea}$
over	incl.	high	low	max.	max.	max.
18	30	0	-12	12	9	18
30	50	0	-14	14	11	20
50	80	0	-16	16	12	25
80	120	0	-18	18	14	35
120	150	0	-20	20	15	40
150	180	0	-25	25	19	45
180	250	0	-30	30	23	50
250	315	0	-35	35	26	60
315	400	0	-40	40	30	70
400	500	0	-45	45	34	80

# Tapered Roller Bearings

**Table 4 Tolerances of Effective Widths of Cone Assemblies and Cups and Overall Width (CLASS K)**

Units :  $\mu\text{m}$

Nominal Bore Diameter d (mm)		Effective Width Deviation of Cone Assembly $\Delta T_{1s}$		Effective Width Deviation of Cup $\Delta T_{2s}$		Overall Width Deviation $\Delta T_s$	
over	incl.	high	low	high	low	high	low
10	80	+100	0	+100	0	+200	0
80	120	+100	-100	+100	-100	+200	-200
120	315	+150	-150	+200	-100	+350	-250
315	400	+200	-200	+200	-200	+400	-400

2. Bearings for Front Axles of Automobiles (In the bearing tables, those preceded by t)

**Table 5 Tolerances of Bore Diameter and Overall Width**

Units :  $\mu\text{m}$

Nominal Bore Diameter d				Bore Diameter Deviation $\Delta d_s$		Overall Width Deviation $\Delta T_s$	
over (mm)	1/25.4	incl. (mm)	1/25.4	high	low	high	low
—		76.200	3.0000	+20	0	+356	0

The tolerances for outside diameter and those for radial runout of the cones and cups conform to Table 8.4.2 (Pages A70 and A71).

3. Special Chamfer Dimensions

For bearings marked "spec." in the column of r in the bearing tables, the chamfer dimension of the cone back-face side is as shown on the following figure.

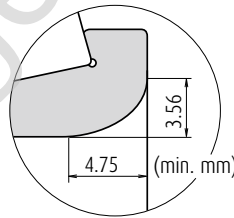

## RECOMMENDED FITS

Metric Design Tapered Roller Bearings

Inch Design Tapered Roller Bearings

Table	Page
9.2 .....	A86
9.4 .....	A87
9.6 .....	A88
9.7 .....	A89

## INTERNAL CLEARANCE

	Table	Page
Metric Design Tapered Roller Bearings (Matched and Double-Row)	9.16 .....	A95
Inch Design Tapered Roller Bearings (Matched and Double-Row)	9.16 .....	A95

## DIMENSIONS RELATED TO MOUNTING

The dimensions related to mounting tapered roller bearings are listed in the bearing tables. Since the cages protrude from the ring faces of tapered roller bearings, please use care when designing shafts and housings.

When heavy axial loads are imposed, the shaft shoulder dimensions and strength must be sufficient to support the cone rib.

## PERMISSIBLE MISALIGNMENT

The permissible misalignment angle for tapered roller bearings is approximately 0.0009 radian (3').

## LIMITING SPEEDS

The limiting speeds listed in the bearing tables should be adjusted depending on the bearing load conditions. Also, higher speeds are attainable by making changes in the lubrication method, cage design, etc. Refer to Page A39 for detailed information.

## PRECAUTIONS FOR USE OF TAPERED ROLLER BEARINGS

1. If the load on tapered roller bearings becomes too small, or if the ratio of the axial and radial loads for matched bearings exceeds 'e' (e is listed in the bearing tables) during operation, slippage between the rollers and raceways occurs, which may result in smearing. Especially with large bearings since the weight of the rollers and cage is high. If such load conditions are expected, please contact NSK for selection of the bearings.
2. Confirm the dimension of "Abutment and Fillet Dimensions" of  $D_a$ ,  $D_b$ ,  $S_a$ ,  $S_b$  at the time of the HR series adoption.



# Single-Row Tapered Roller Bearings

Bore Diameter 15 – 28 mm

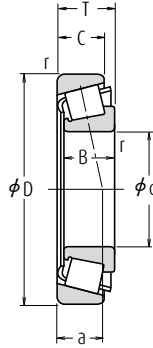

d	Boundary Dimensions (mm)					Basic Load Ratings (N) {kgf}				Limiting Speeds (min <sup>-1</sup> )		
	D	T	B	C	r min.	C <sub>r</sub>	C <sub>0r</sub>	C <sub>r</sub>	C <sub>0r</sub>	Grease	Oil	
15	35	11.75	11	10	0.6	14 800	13 200	1 510	1 350	11 000	15 000	
	42	14.25	13	11	1	23 600	21 100	2 400	2 160	9 500	13 000	
17	40	13.25	12	11	1	20 100	19 900	2 050	2 030	9 500	13 000	
	40	17.25	16	14	1	27 100	28 000	2 770	2 860	9 500	13 000	
47	15.25	14	12	1	1	29 200	26 700	2 980	2 720	8 500	12 000	
47	15.25	14	10.5	1	1	22 000	20 300	2 240	2 070	8 000	11 000	
47	20.25	19	16	1	1	37 500	36 500	3 800	3 750	8 500	11 000	
20	42	15	15	12	0.6	0.6	24 600	27 400	2 510	2 800	9 000	12 000
	47	15.25	14	12	1	1	27 900	28 500	2 850	2 900	8 000	11 000
47	15.25	14	12	0.3	1	23 900	24 000	2 430	2 450	8 000	11 000	
47	19.25	18	15	1	1	35 500	37 500	3 650	3 850	8 500	11 000	
47	19.25	18	15	1	1	31 500	33 500	3 200	3 400	8 000	11 000	
52	16.25	15	13	1.5	1.5	35 000	33 500	3 550	3 400	7 500	10 000	
52	16.25	15	12	1.5	1.5	25 300	24 500	2 580	2 490	7 100	10 000	
52	22.25	21	18	1.5	1.5	45 500	47 500	4 650	4 850	8 000	11 000	
22	44	15	15	11.5	0.6	0.6	25 600	29 400	2 610	3 000	8 500	11 000
	50	15.25	14	12	1	1	29 200	30 500	2 980	3 150	7 500	10 000
50	15.25	14	12	1	1	27 200	29 500	2 780	3 000	7 500	10 000	
50	19.25	18	15	1	1	36 500	40 500	3 750	4 100	7 500	11 000	
50	19.25	18	15	1	1	33 500	39 500	3 400	4 000	7 500	10 000	
56	17.25	16	14	1.5	1.5	37 000	36 500	3 750	3 750	7 100	9 500	
56	17.25	16	13	1.5	1.5	34 500	34 000	3 500	3 500	6 700	9 500	
25	47	15	15	11.5	0.6	0.6	27 400	33 000	2 800	3 400	8 000	11 000
	47	17	17	14	0.6	0.6	31 000	38 000	3 150	3 900	8 000	11 000
52	16.25	15	13	1	1	32 000	35 000	3 300	3 550	7 100	10 000	
52	16.25	15	12	1	1	28 100	31 500	2 860	3 200	9 700	9 500	
52	19.25	18	16	1	1	40 000	45 000	4 050	4 600	7 100	10 000	
52	19.25	18	15	1	1	35 000	42 000	3 550	4 250	7 100	9 500	
52	22	22	18	1	1	47 500	56 500	4 850	5 750	7 500	10 000	
62	18.25	17	15	1.5	1.5	47 500	46 000	4 850	4 700	6 300	8 500	
62	18.25	17	14	1.5	1.5	42 000	45 000	4 300	4 550	6 000	8 500	
62	18.25	17	13	1.5	1.5	38 000	40 500	3 900	4 100	5 600	8 000	
62	18.25	17	13	1.5	1.5	38 000	40 500	3 900	4 100	5 600	8 000	
62	25.25	24	20	1.5	1.5	62 500	66 000	6 400	6 750	6 300	8 500	
28	52	16	16	12	1	1	32 000	39 000	3 300	3 950	7 100	9 500
	58	17.25	16	14	1	1	39 500	41 500	4 050	4 200	6 300	9 000
58	17.25	16	12	1	1	34 000	38 500	3 450	3 900	6 300	8 500	
58	20.25	19	16	1	1	47 500	54 000	4 850	5 500	6 300	9 000	
58	20.25	19	16	1	1	42 000	49 500	4 300	5 050	6 300	9 000	
68	19.75	18	15	1.5	1.5	55 000	55 500	5 650	5 650	6 000	8 000	
68	19.75	18	14	1.5	1.5	49 500	50 500	5 000	5 150	5 600	7 500	

**Remarks** The suffix C represents medium-angle tapered roller bearings. Since they are designed for specific applications, please consult NSK when using bearings with suffix C.

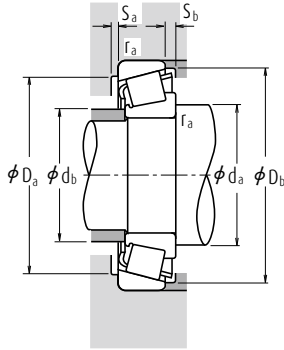

### Dynamic Equivalent Load $P = X F_r + Y F_a$

$F_a/F_r \leq e$		$F_a/F_r > e$	
X	Y	X	Y
1	0	0.4	$Y_1$

### Static Equivalent Load

$$P_0 = 0.5 F_r + Y_0 F_a$$

When  $F_r > 0.5 F_r + Y_0 F_a$ , use  $P_0 = F_r$

The values of  $e$ ,  $Y_1$  and  $Y_0$  are given in the table below.

Bearing Numbers	ISO355 Dimension Series	Abutment and Fillet Dimensions (mm)									Eff. Load Centers (mm)	Constant	Axial Load Factors		Mass (kg)			
		approx.	$d_a$	$d_b$	$D_a$	$D_b$	$S_a$	$S_b$	Cone Cup				a	e		$Y_1$	$Y_0$	approx.
			min.	max.	max.	min.	min.	min.	min.	$r_a$								
30202	—	23	19	30	30	33	2	1.5	0.6	0.6	8.2	0.32	1.9	1.0	0.053			
HR 30302 J	2FB	24	22	36	36	38.5	2	3	1	1	9.5	0.29	2.1	1.2	0.098			
HR 30203 J	2DB	26	23	34	34	37.5	2	2	1	1	9.7	0.35	1.7	0.96	0.079			
HR 32203 J	2DD	26	22	34	34	37	2	3	1	1	11.2	0.31	1.9	1.1	0.103			
HR 30303 J	2FB	26	24	41	40	43	2	3	1	1	10.4	0.29	2.1	1.2	0.134			
30303 D	—	29	23	41	34	44	2	4.5	1	1	15.4	0.81	0.74	0.41	0.129			
HR 32303 J	2FD	28	23	41	39	43	2	4	1	1	12.5	0.29	2.1	1.2	0.178			
HR 32004 XJ	3CC	28	24	37	35	40	3	3	0.6	0.6	10.6	0.37	1.6	0.88	0.097			
HR 30204 J	2DB	29	27	41	40	44	2	3	1	1	11.0	0.35	1.7	0.96	0.127			
HR 30204 C-A	—	29	26	41	37	44	2	3	0.3	1	13.0	0.55	1.1	0.60	0.126			
HR 32204 J	2DD	29	25	41	38	44.5	3	4	1	1	12.6	0.33	1.8	1.0	0.161			
HR 32204 CJ	5DD	29	25	41	36	44	2	4	1	1	14.5	0.52	1.2	0.64	0.166			
HR 30304 J	2FB	31	27	44	44	47.5	2	3	1.5	1.5	11.6	0.30	2.0	1.1	0.172			
30304 D	—	34	26	43	37	49	2	4	1.5	1.5	16.7	0.81	0.74	0.41	0.168			
HR 32304 J	2FD	33	26	43	42	48	3	4	1.5	1.5	13.9	0.30	2.0	1.1	0.241			
HR 320/22 XJ	3CC	30	27	39	37	42	3	3.5	0.6	0.6	11.1	0.40	1.5	0.83	0.103			
HR 302/22	—	31	29	44	42	47	2	3	1	1	11.6	0.37	1.6	0.90	0.139			
HR 302/22 C	—	31	29	44	40	47	2	3	1	1	13.0	0.49	1.2	0.67	0.144			
HR 322/22	—	31	28	44	41	47	2	4	1	1	13.5	0.37	1.6	0.89	0.18			
HR 322/22 C	—	31	29	44	39	48	2	4	1	1	15.2	0.51	1.2	0.65	0.185			
HR 303/22	—	33	30	47	46	50	2	3	1.5	1.5	12.4	0.32	1.9	1.0	0.208			
HR 303/22 C	—	33	30	47	44	52.5	3	4	1.5	1.5	15.9	0.59	1.0	0.56	0.207			
HR 32005 XJ	4CC	33	30	42	40	45	3	3.5	0.6	0.6	11.8	0.43	1.4	0.77	0.116			
HR 33005 J	2CE	33	29	42	41	44	3	3	0.6	0.6	11.0	0.29	2.1	1.1	0.131			
HR 30205 J	3CC	34	31	46	44	48.5	2	3	1	1	12.7	0.37	1.6	0.88	0.157			
HR 30205 C	—	34	32	46	43	49.5	2	4	1	1	14.4	0.53	1.1	0.62	0.155			
HR 32205 J	2CD	34	30	46	44	50	2	3	1	1	13.5	0.36	1.7	0.92	0.189			
HR 32205 C	—	34	30	46	40	50	2	4	1	1	15.8	0.53	1.1	0.62	0.19			
HR 33205 J	2DE	34	29	46	43	49.5	4	4	1	1	14.1	0.35	1.7	0.94	0.221			
HR 30305 J	2FB	36	34	54	54	57	2	3	1.5	1.5	13.2	0.30	2.0	1.1	0.27			
HR 30305 C	—	36	35	53	49	58.5	3	4	1.5	1.5	16.4	0.55	1.1	0.60	0.276			
HR 30305 DJ	(7FB)	39	34	53	47	59	2	5	1.5	1.5	19.9	0.83	0.73	0.40	0.265			
HR 31305 J	7FB	39	33	53	47	59	3	5	1.5	1.5	19.9	0.83	0.73	0.40	0.265			
HR 32305 J	2FD	38	32	53	51	57	3	5	1.5	1.5	15.6	0.30	2.0	1.1	0.376			
HR 320/28 XJ	4CC	37	33	46	44	50	3	4	1	1	12.8	0.43	1.4	0.77	0.146			
HR 302/28	—	37	34	52	50	55	2	3	1	1	13.2	0.35	1.7	0.93	0.203			
HR 302/28 C	—	37	34	52	48	54	2	5	1	1	16.9	0.64	0.94	0.52	0.198			
HR 322/28	—	37	34	52	49	55	2	4	1	1	14.6	0.37	1.6	0.89	0.243			
HR 322/28 CJ	5DD	37	33	52	45	55	2	4	1	1	16.8	0.56	1.1	0.59	0.251			
HR 303/28	—	39	37	59	58	61	2	4.5	1.5	1.5	14.5	0.31	1.9	1.1	0.341			
HR 303/28 C	—	39	38	59	57	63	3	5.5	1.5	1.5	17.4	0.52	1.2	0.64	0.335			



# Single-Row Tapered Roller Bearings

Bore Diameter 30 – 35 mm

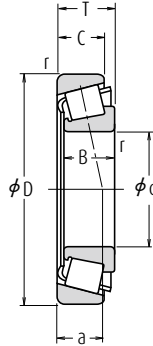

d	Boundary Dimensions (mm)					Cone		Basic Load Ratings (N)				Limiting Speeds (min <sup>-1</sup> )	
	D	T	B	C	r min.	Cup	C <sub>r</sub>	C <sub>0r</sub>	C <sub>r</sub>	C <sub>0r</sub>	Grease	Oil	
30	47	12	12	9	0.3	0.3	17 600	24 400	1 800	2 490	7 500	10 000	
	55	17	17	13	1	1	36 000	44 500	3 700	4 550	6 700	9 000	
	55	20	20	16	1	1	42 000	54 000	4 250	5 500	6 700	9 000	
	62	17.25	16	14	1	1	43 000	47 500	4 400	4 850	6 000	8 000	
	62	17.25	16	12	1	1	35 500	37 000	3 650	3 800	5 600	7 500	
	62	21.25	20	17	1	1	52 000	60 000	5 300	6 150	6 000	8 500	
	62	21.25	20	16	1	1	48 000	56 000	4 900	5 750	6 000	8 000	
	62	25	25	19.5	1	1	66 500	79 500	6 800	8 100	6 000	8 000	
	72	20.75	19	16	1.5	1.5	59 500	60 000	6 050	6 100	5 300	7 500	
	72	20.75	19	14	1.5	1.5	56 500	55 500	5 800	5 650	5 300	7 100	
	72	20.75	19	14	1.5	1.5	49 000	52 500	5 000	5 350	4 800	6 700	
	72	20.75	19	14	1.5	1.5	49 000	52 500	5 000	5 350	4 800	6 800	
	72	28.75	27	23	1.5	1.5	80 000	88 500	8 150	9 000	5 600	7 500	
	72	28.75	27	23	1.5	1.5	76 000	86 500	7 750	8 800	5 600	7 500	
32	58	17	17	13	1	1	37 500	47 000	3 800	4 800	6 300	8 500	
	58	21	20	16	1	1	41 000	50 000	4 150	5 100	6 300	8 500	
	65	18.25	17	15	1	1	48 500	54 000	4 950	5 500	5 600	8 000	
	65	18.25	17	14	1	1	45 500	52 500	4 650	5 350	5 600	7 500	
	65	22.25	21	18	1	1	56 000	65 000	5 700	6 650	6 000	8 000	
	65	22.25	21	17	1	1	49 500	60 000	5 050	6 100	5 600	7 500	
	65	26	26	20.5	1	1	70 000	86 500	7 150	8 850	5 600	8 000	
	75	21.75	20	17	1.5	1.5	56 000	56 000	5 700	5 700	5 300	7 100	
35	55	14	14	11.5	0.6	0.6	27 400	39 000	2 790	3 950	6 300	8 500	
	62	18	18	14	1	1	43 500	55 500	4 400	5 650	5 600	8 000	
	62	21	21	17	1	1	49 000	65 000	4 950	6 650	5 600	8 000	
	72	18.25	17	15	1.5	1.5	54 000	59 500	5 500	6 050	5 300	7 100	
	72	18.25	17	13	1.5	1.5	47 000	54 500	4 750	5 550	5 000	6 700	
	72	24.25	23	19	1.5	1.5	70 500	83 500	7 150	8 550	5 300	7 100	
	72	24.25	23	18	1.5	1.5	60 500	71 500	6 200	7 300	5 000	7 100	
	72	28	28	22	1.5	1.5	86 500	108 000	8 850	11 100	5 300	7 100	
	80	22.75	21	18	2	1.5	76 000	79 000	7 750	8 050	4 800	6 700	
	80	22.75	21	16	2	1.5	68 000	70 500	6 900	7 200	4 800	6 300	
	80	22.75	21	15	2	1.5	62 000	68 000	6 350	6 950	4 300	6 000	
	80	22.75	21	15	2	1.5	62 000	68 000	6 350	6 950	4 300	6 000	
	80	32.75	31	25	2	1.5	99 000	111 000	10 100	11 300	5 000	6 700	

**Remarks** The suffix C represents medium-angle tapered roller bearings. Since they are designed for specific applications, please consult NSK when using bearings with suffix C.

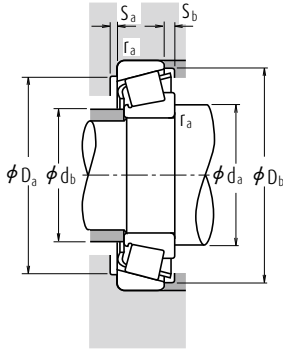

### Dynamic Equivalent Load $P = X F_r + Y F_a$

$F_a/F_r \leq e$		$F_a/F_r > e$	
X	Y	X	Y
1	0	0.4	$Y_1$

### Static Equivalent Load

$$P_0 = 0.5 F_r + Y_0 F_a$$

When  $F_r > 0.5 F_r + Y_0 F_a$ , use  $P_0 = F_r$

The values of  $e$ ,  $Y_1$  and  $Y_0$  are given in the table below.

Bearing Numbers	ISO355 Dimension Series	Abutment and Fillet Dimensions (mm)										Eff. Load Centers (mm)	Constant	Axial Load Factors		Mass (kg)			
		$d_a$ approx.	$d_b$ min.	$d_b$ max.	$D_a$ max.	$d_b$ min.	$d_b$ max.	$S_a$ min.	$S_b$ min.	Cone Cup				a	e		$Y_1$	$Y_0$	approx.
										$r_a$ max.	$r_a$ max.								
HR 32906 J	2BD	34	34	44	42	44	3	3	0.3	0.3	9.2	0.32	1.9	1.0	0.074				
HR 32006 XJ	4CC	39	35	49	47	53	3	4	1	1	13.5	0.43	1.4	0.77	0.172				
HR 33006 J	2CE	39	35	49	48	52	3	4	1	1	13.1	0.29	2.1	1.1	0.208				
HR 32026 J	3DB	39	37	56	52	58	2	3	1	1	13.9	0.37	1.6	0.88	0.238				
HR 32026 C	—	39	36	56	49	59	2	5	1	1	17.8	0.68	0.88	0.49	0.221				
HR 32206 J	3DC	39	36	56	51	58.5	2	4	1	1	15.4	0.37	1.6	0.88	0.297				
HR 32206 C	—	39	35	56	48	59	2	5	1	1	17.8	0.55	1.1	0.60	0.293				
HR 33206 J	2DE	39	35	56	52	59.5	5	5.5	1	1	16.1	0.34	1.8	0.97	0.355				
HR 30306 J	2FB	41	40	63	62	66	3	4.5	1.5	1.5	15.1	0.32	1.9	1.1	0.403				
HR 30306 C	—	41	38	63	59	67	3	6.5	1.5	1.5	18.5	0.55	1.1	0.60	0.383				
HR 30306 DJ	(7FB)	44	40	63	55	68	3	6.5	1.5	1.5	23.1	0.83	0.73	0.40	0.393				
HR 31306 J	7FB	44	40	63	55	68	3	6.5	1.5	1.5	23.1	0.83	0.73	0.40	0.393				
HR 32306 J	2FD	43	38	63	59	66	3	5.5	1.5	1.5	18.0	0.32	1.9	1.1	0.57				
HR 32306 CJ	5FD	43	36	63	54	68	3	5.5	1.5	1.5	22.0	0.55	1.1	0.60	0.583				
HR 320/32 XJ	4CC	41	37	52	49	55	3	4	1	1	14.2	0.45	1.3	0.73	0.191				
330/32	—	41	37	52	50	55	2	4	1	1	13.8	0.31	1.9	1.1	0.225				
HR 302/32	—	41	39	59	56	61	3	3	1	1	14.7	0.37	1.6	0.88	0.277				
HR 302/32 C	—	41	39	59	54	62	3	4	1	1	16.9	0.55	1.1	0.60	0.273				
HR 322/32	—	41	38	59	54	61	3	4	1	1	15.9	0.37	1.6	0.88	0.336				
HR 322/32 C	—	41	39	59	51	62	3	5	1	1	20.2	0.59	1.0	0.56	0.335				
HR 332/32 J	2DE	41	38	59	55	62	5	5.5	1	1	17.0	0.35	1.7	0.95	0.40				
303/32	—	44	42	66	64	68	3	4.5	1.5	1.5	15.9	0.33	1.8	1.0	0.435				
HR 32907 J	2BD	43	40	50	50	52.5	3	2.5	0.6	0.6	10.7	0.29	2.1	1.1	0.123				
HR 32007 XJ	4CC	44	40	56	54	60	4	4	1	1	15.0	0.45	1.3	0.73	0.229				
HR 33007 J	2CE	44	40	56	55	59	4	4	1	1	14.1	0.31	2.0	1.1	0.267				
HR 30207 J	3DB	46	43	63	62	67	3	3	1.5	1.5	15.0	0.37	1.6	0.88	0.34				
HR 30207 C	—	46	44	63	59	68	3	5	1.5	1.5	19.6	0.66	0.91	0.50	0.331				
HR 32207 J	3DC	46	42	63	61	67.5	3	5	1.5	1.5	17.9	0.37	1.6	0.88	0.456				
HR 32207 C	—	46	42	63	58	68.5	3	6	1.5	1.5	20.6	0.55	1.1	0.60	0.442				
HR 33207 J	2DE	46	41	63	61	68	5	6	1.5	1.5	18.3	0.35	1.7	0.93	0.54				
HR 30307 J	2FB	47	45	71	69	74	3	4.5	2	1.5	16.7	0.32	1.9	1.1	0.538				
HR 30307 C	—	47	44	71	65	74	3	6.5	2	1.5	20.3	0.55	1.1	0.60	0.518				
HR 30307 DJ	7FB	51	44	71	62	77	3	7.5	2	1.5	25.2	0.83	0.73	0.40	0.519				
HR 31307 J	7FB	51	44	71	62	77	3	7.5	2	1.5	25.2	0.83	0.73	0.40	0.52				
HR 32307 J	2FE	49	43	71	66	74	3	7.5	2	1.5	20.7	0.32	1.9	1.1	0.765				

# Single-Row Tapered Roller Bearings

Bore Diameter 40 - 50 mm

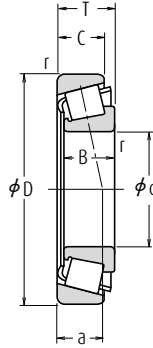

d	Boundary Dimensions (mm)					Basic Load Ratings (N)				Limiting Speeds (min <sup>-1</sup> )	
	D	T	B	C	r min.	C <sub>r</sub>	C <sub>0r</sub>	C <sub>r</sub>	C <sub>0r</sub>	Grease	Oil
40	62	15	15	12	0.6	34 000	47 000	3 450	4 800	5 600	7 500
	68	19	19	14.5	1	53 000	71 000	5 400	7 250	5 300	7 100
	68	22	22	18	1	59 000	81 500	6 000	8 300	5 300	7 100
	75	26	26	20.5	1.5	78 500	101 000	8 000	10 300	4 800	6 700
	80	19.75	18	16	1.5	63 500	70 000	6 450	7 150	4 800	6 300
	80	24.75	23	19	1.5	77 000	90 500	7 900	9 200	4 800	6 300
	80	24.75	23	19	1.5	74 000	90 500	7 550	9 200	4 500	6 300
	80	32	32	25	1.5	107 000	137 000	10 900	14 000	4 800	6 300
	90	25.25	23	20	2	90 500	101 000	9 250	10 300	4 300	5 600
	90	25.25	23	18	2	84 500	93 500	8 600	9 500	4 300	5 600
	90	25.25	23	17	2	80 000	89 500	8 150	9 150	3 800	5 300
	90	25.25	23	17	2	80 000	89 500	8 150	9 150	3 800	5 300
90	35.25	33	27	2	120 000	145 000	12 200	14 800	4 300	6 000	
45	68	15	15	12	0.6	34 500	50 500	3 550	5 150	5 000	6 700
	75	20	20	15.5	1	60 000	83 000	6 150	8 450	4 500	6 300
	75	24	24	19	1	69 000	99 000	7 050	10 100	4 800	6 300
	80	26	26	20.5	1.5	84 000	113 000	8 550	11 600	4 500	6 000
	85	20.75	19	16	1.5	68 500	79 500	6 950	8 100	4 300	6 000
	85	24.75	23	19	1.5	83 000	102 000	8 500	10 400	4 300	6 000
	85	24.75	23	19	1.5	75 500	95 500	7 700	9 750	4 300	5 600
	85	32	32	25	1.5	111 000	147 000	11 300	15 000	4 300	6 000
	95	29	26.5	20	2.5	88 500	109 000	9 050	11 100	3 600	5 000
	95	36	35	30	2.5	139 000	174 000	14 200	17 800	4 000	5 300
	100	27.25	25	22	2	112 000	127 000	11 400	12 900	3 800	5 300
	100	27.25	25	18	2	95 500	109 000	9 750	11 100	3 400	4 800
100	27.25	25	18	2	95 500	109 000	9 750	11 100	3 400	4 800	
100	38.25	36	30	2	144 000	177 000	14 700	18 000	3 800	5 300	
50	100	36	35	30	2.5	144 000	185 000	14 600	18 800	3 800	5 000
	72	15	15	12	0.6	36 000	54 000	3 650	5 500	4 500	6 300
	80	20	20	15.5	1	61 000	87 000	6 250	8 900	4 300	6 000
	80	24	24	19	1	70 500	104 000	7 150	10 600	4 300	6 000
	85	26	26	20	1.5	89 000	126 000	9 100	12 800	4 300	5 600
	90	21.75	20	17	1.5	76 000	91 500	7 750	9 300	4 000	5 300
	90	24.75	23	19	1.5	87 500	109 000	8 900	11 100	4 000	5 300
	90	24.75	23	18	1.5	77 500	102 000	7 900	10 400	3 800	5 300
	90	32	32	24.5	1.5	118 000	165 000	12 100	16 800	4 000	5 300
	105	32	29	22	3	109 000	133 000	11 100	13 600	3 200	4 500
	110	29.25	27	23	2.5	130 000	148 000	13 300	15 100	3 400	4 800
	110	29.25	27	19	2.5	114 000	132 000	11 700	13 400	3 200	4 300
110	29.25	27	19	2.5	114 000	132 000	11 700	13 400	3 200	4 300	
110	42.25	40	33	2.5	176 000	220 000	17 900	22 400	3 600	4 800	
110	42.25	40	33	2.5	164 000	218 000	16 800	22 200	3 400	4 800	

**Remarks** The suffix C represents medium-angle tapered roller bearings. Since they are designed for specific applications, please consult NSK when using bearings with suffix C.

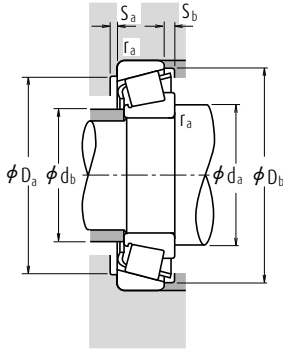

### Dynamic Equivalent Load $P = X F_r + Y F_a$

$F_a/F_r \leq e$		$F_a/F_r > e$	
X	Y	X	Y
1	0	0.4	$Y_1$

### Static Equivalent Load

$$P_0 = 0.5 F_r + Y_0 F_a$$

When  $F_r > 0.5 F_r + Y_0 F_a$ , use  $P_0 = F_r$

The values of  $e$ ,  $Y_1$  and  $Y_0$  are given in the table below.

Bearing Numbers	ISO355 Dimension Series	Abutment and Fillet Dimensions (mm)								Eff. Load Centers (mm)	Constant	Axial Load Factors		Mass (kg)		
		$d_a$		$d_b$		$D_a$		$D_b$				Cone	Cup		$Y_1$	$Y_0$
		approx.	min.	max.	min.	max.	min.	max.	min.							
HR 32908 J	2BC	48	44	57	57	59	3	3	0.6	0.6	11.5	0.29	2.1	1.1	0.161	
HR 32008 XJ	3CD	49	45	62	60	65.5	4	4.5	1	1	15.0	0.38	1.6	0.87	0.28	
HR 33008 J	2BE	49	45	62	61	65	4	4	1	1	14.6	0.28	2.1	1.2	0.322	
HR 33108 J	2CE	51	46	66	65	71	4	5.5	1.5	1.5	18.0	0.36	1.7	0.93	0.503	
HR 30208 J	3DB	51	48	71	69	75	3	3.5	1.5	1.5	16.6	0.37	1.6	0.88	0.437	
HR 32208 J	3DC	51	48	71	68	75	3	5.5	1.5	1.5	18.9	0.37	1.6	0.88	0.548	
HR 32208 CJ	5DC	51	47	71	65	76	3	5.5	1.5	1.5	21.9	0.55	1.1	0.60	0.558	
HR 33208 J	2DE	51	46	71	67	76	5	7	1.5	1.5	20.8	0.36	1.7	0.92	0.744	
HR 30308 J	2FB	52	52	81	76	82	3	5	2	1.5	19.5	0.35	1.7	0.96	0.758	
HR 30308 C	—	52	50	81	72	84	3	7	2	1.5	22.8	0.53	1.1	0.62	0.735	
HR 30308 DJ	7FB	56	50	81	70	87	3	8	2	1.5	28.7	0.83	0.73	0.40	0.728	
HR 31308 J	7FB	56	50	81	70	87	3	8	2	1.5	28.7	0.83	0.73	0.40	0.728	
HR 32308 J	2FD	54	50	81	73	82	3	8	2	1.5	23.4	0.35	1.7	0.96	1.05	
HR 32909 J	2BC	53	50	63	62	64	3	3	0.6	0.6	12.3	0.32	1.9	1.0	0.187	
HR 32009 XJ	3CC	54	51	69	67	72	4	4.5	1	1	16.6	0.39	1.5	0.84	0.354	
HR 33009 J	2CE	54	51	69	67	71	4	5	1	1	16.3	0.29	2.0	1.1	0.414	
HR 33109 J	3CE	56	51	71	69	77	4	5.5	1.5	1.5	19.1	0.38	1.6	0.86	0.552	
HR 30209 J	3DB	56	53	76	74	80	3	4.5	1.5	1.5	18.3	0.41	1.5	0.81	0.488	
HR 32209 J	3DC	56	53	76	73	81	3	5.5	1.5	1.5	20.1	0.41	1.5	0.81	0.602	
HR 32209 CJ	5DC	56	52	76	70	82	3	5.5	1.5	1.5	23.6	0.59	1.0	0.56	0.603	
HR 33209 J	3DE	56	51	76	72	81	5	7	1.5	1.5	22.0	0.39	1.6	0.86	0.817	
T7 FC045	7FC	60	53	83	71	91	3	9	2	2	32.1	0.87	0.69	0.38	0.918	
T2 ED045	2ED	60	54	83	79	89	5	6	2	2	23.5	0.32	1.9	1.02	1.22	
HR 30309 J	2FB	57	58	91	86	93	3	5	2	1.5	21.1	0.35	1.7	0.96	1.01	
HR 30309 DJ	7FB	61	57	91	79	96	3	9	2	1.5	31.5	0.83	0.73	0.40	0.957	
HR 31309 J	7FB	61	57	91	79	96	3	9	2	1.5	31.5	0.83	0.73	0.40	0.947	
HR 32309 J	2FD	59	56	91	82	93	3	8	2	1.5	25.0	0.35	1.7	0.96	1.42	
T2 ED050	2ED	65	59	88	83	94	6	6	2	2	24.2	0.34	1.8	0.96	1.3	
HR 32910 J	2BC	58	54	67	66	69	3	3	0.6	0.6	13.5	0.34	1.8	0.97	0.193	
HR 32010 XJ	3CC	59	56	74	71	77	4	4.5	1	1	17.9	0.42	1.4	0.78	0.38	
HR 33010 J	2CE	59	55	74	71	76	4	5	1	1	17.4	0.32	1.9	1.0	0.452	
HR 33110 J	3CE	61	56	76	74	82	4	6	1.5	1.5	20.3	0.41	1.5	0.8	0.597	
HR 30210 J	3DB	61	58	81	79	85	3	4.5	1.5	1.5	19.6	0.42	1.4	0.79	0.557	
HR 32210 J	3DC	61	57	81	78	86	3	5.5	1.5	1.5	21.0	0.42	1.4	0.79	0.642	
HR 32210 CJ	5DC	61	58	81	76	87	3	6.5	1.5	1.5	24.6	0.59	1.0	0.56	0.655	
HR 33210 J	3DE	61	56	81	76	87	5	7.5	1.5	1.5	23.2	0.41	1.5	0.80	0.867	
T7 FC050	7FC	74	59	91	78	100	5	10	2.5	2.5	36.4	0.87	0.69	0.38	1.22	
HR 30310 J	2FB	65	65	100	95	102	3	6	2	2	23.1	0.35	1.7	0.96	1.28	
HR 30310 DJ	7FB	70	62	100	87	105	3	10	2	2	34.3	0.83	0.73	0.40	1.26	
HR 31310 J	7FB	70	62	100	87	105	3	10	2	2	34.3	0.83	0.73	0.40	1.26	
HR 32310 J	2FD	68	62	100	91	102	3	9	2	2	28.0	0.35	1.7	0.96	1.88	
HR 32310 CJ	5FD	68	59	100	82	103	3	9	2	2	32.8	0.55	1.1	0.60	1.93	

# Single-Row Tapered Roller Bearings

Bore Diameter 55 – 65 mm

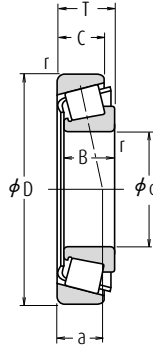

d	Boundary Dimensions (mm)					Cone		Basic Load Ratings (N)				Limiting Speeds (min <sup>-1</sup> )	
	D	T	B	C	r	Cup	C <sub>r</sub>	C <sub>0r</sub>	C <sub>r</sub>	C <sub>0r</sub>	Grease	Oil	
55	80	17	17	14	1	1	45 500	74 500	4 600	7 600	4 300	5 600	
	90	23	23	17.5	1.5	1.5	81 500	117 000	8 300	11 900	3 800	5 300	
	90	27	27	21	1.5	1.5	91 500	138 000	9 300	14 000	3 800	5 300	
	95	30	30	23	1.5	1.5	112 000	158 000	11 500	16 100	3 800	5 000	
	100	22.75	21	18	2	1.5	94 500	113 000	9 650	11 500	3 600	5 000	
	100	26.75	25	21	2	1.5	110 000	137 000	11 200	14 000	3 600	5 000	
	100	35	35	27	2	1.5	141 000	193 000	14 400	19 700	3 600	5 000	
	115	34	31	23.5	3	3	126 000	164 000	12 800	16 700	3 000	4 300	
	120	31.5	29	25	2.5	2	150 000	171 000	15 200	17 500	3 200	4 300	
	120	31.5	29	21	2.5	2	131 000	153 000	13 400	15 600	2 800	4 000	
	120	31.5	29	21	2.5	2	131 000	153 000	13 400	15 600	2 800	4 000	
	120	45.5	43	35	2.5	2	204 000	258 000	20 800	26 300	3 200	4 300	
120	45.5	43	35	2.5	2	195 000	262 000	19 900	26 700	3 200	4 300		
60	85	17	17	14	1	1	49 000	84 500	5 000	8 650	3 800	5 300	
	95	23	23	17.5	1.5	1.5	85 500	127 000	8 700	12 900	3 600	5 000	
	95	27	27	21	1.5	1.5	96 000	150 000	9 800	15 300	3 600	5 000	
	100	30	30	23	1.5	1.5	115 000	166 000	11 700	16 900	3 400	4 800	
	110	23.75	22	19	2	1.5	104 000	123 000	10 600	12 500	3 400	4 500	
	110	29.75	28	24	2	1.5	131 000	167 000	13 400	17 000	3 400	4 500	
	110	38	38	29	2	1.5	166 000	231 000	16 900	23 600	3 400	4 500	
	125	37	33.5	26	3	3	151 000	197 000	15 400	20 100	2 800	3 800	
	130	33.5	31	26	3	2.5	174 000	201 000	17 700	20 500	3 000	4 000	
	130	33.5	31	22	3	2.5	151 000	177 000	15 400	18 100	2 600	3 800	
	130	33.5	31	22	3	2.5	151 000	177 000	15 400	18 100	2 600	3 800	
	130	48.5	46	37	3	2.5	233 000	295 000	23 700	30 000	3 000	4 000	
130	48.5	46	35	3	2.5	196 000	249 000	20 000	25 400	2 800	3 800		
65	90	17	17	14	1	1	49 000	86 500	5 000	8 800	3 600	5 000	
	100	23	23	17.5	1.5	1.5	86 500	132 000	8 800	13 500	3 400	4 500	
	100	27	27	21	1.5	1.5	97 500	156 000	9 950	15 900	3 400	4 500	
	110	34	34	26.5	1.5	1.5	148 000	218 000	15 100	22 200	3 200	4 300	
	120	24.75	23	20	2	1.5	122 000	151 000	12 500	15 400	3 000	4 000	
	120	32.75	31	27	2	1.5	157 000	202 000	16 000	20 600	3 000	4 000	
	120	41	41	32	2	1.5	202 000	282 000	20 600	28 800	3 000	4 000	
	140	36	33	28	3	2.5	200 000	233 000	20 400	23 800	2 600	3 600	
	140	36	33	23	3	2.5	173 000	205 000	17 700	20 900	2 400	3 400	
	140	36	33	23	3	2.5	173 000	205 000	17 700	20 900	2 400	3 400	
	140	51	48	39	3	2.5	267 000	340 000	27 300	35 000	2 800	3 800	

**Remarks** The suffix C represents medium-angle tapered roller bearings. Since they are designed for specific applications, please consult NSK when using bearings with suffix C.

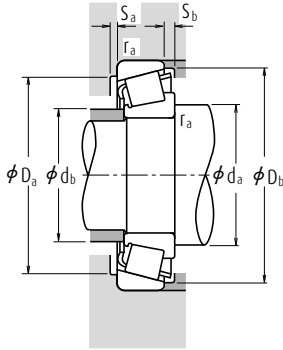

### Dynamic Equivalent Load $P = X F_r + Y F_a$

$F_a/F_r \leq e$		$F_a/F_r > e$	
X	Y	X	Y
1	0	0.4	$Y_1$

### Static Equivalent Load

$P_0 = 0.5 F_r + Y_0 F_a$   
 When  $F_r > 0.5 F_r + Y_0 F_a$ , use  $P_0 = F_r$

The values of  $e$ ,  $Y_1$  and  $Y_0$  are given in the table below.

Bearing Numbers	ISO355 Dimension Series	Abutment and Fillet Dimensions (mm)										Eff. Load Centers (mm)	Constant	Axial Load Factors		Mass (kg)		
		$d_a$		$d_b$		$D_a$		$D_b$		Cone Cup				a	e		$Y_1$	$Y_0$
		approx.	min.	max.	min.	max.	min.	max.	min.	max.	max.							
HR 32911 J	2BC	64	60	74	73	76	4	3	1	1	14.6	0.31	1.9	1.1	0.282			
HR 32011 Xj	3CC	66	62	81	80	86	4	5.5	1.5	1.5	19.7	0.41	1.5	0.81	0.568			
HR 33011 J	2CE	66	62	81	80	86	5	6	1.5	1.5	19.2	0.31	1.9	1.1	0.657			
HR 33111 J	3CE	66	62	86	82	91	5	7	1.5	1.5	22.4	0.37	1.6	0.88	0.877			
HR 30211 J	3DB	67	64	91	89	94	4	4.5	2	1.5	20.9	0.41	1.5	0.81	0.736			
HR 32211 J	3DC	67	63	91	87	95	4	5.5	2	1.5	22.7	0.41	1.5	0.81	0.859			
HR 33211 J	3DE	67	62	91	86	96	6	8	2	1.5	25.2	0.40	1.5	0.83	1.18			
T7 FC055	7FC	73	66	101	86	109	4	10.5	2.5	2.5	39.0	0.87	0.69	0.38	1.58			
HR 30311 J	2FB	70	71	110	104	111	4	6.5	2	2	24.6	0.35	1.7	0.96	1.63			
HR 30311 DJ	7FB	75	67	110	94	114	4	10.5	2	2	37.0	0.83	0.73	0.40	1.58			
HR 31311 J	7FB	75	67	110	94	114	4	10.5	2	2	37.0	0.83	0.73	0.40	1.58			
HR 32311 J	2FD	73	67	110	99	111	4	10.5	2	2	29.9	0.35	1.7	0.96	2.39			
HR 32311 CJ	5FD	73	65	110	91	112	4	10.5	2	2	35.8	0.55	1.1	0.60	2.47			
HR 32912 J	2BC	69	65	79	78	81	4	3	1	1	15.5	0.33	1.8	1.0	0.306			
HR 32012 Xj	4CC	71	66	86	85	91	4	5.5	1.5	1.5	20.9	0.43	1.4	0.77	0.608			
HR 33012 J	2CE	71	66	86	85	90	5	6	1.5	1.5	20.0	0.33	1.8	1.0	0.713			
HR 33112 J	3CE	71	68	91	88	96	5	7	1.5	1.5	23.6	0.40	1.5	0.83	0.91			
HR 30212 J	3EB	72	69	101	96	103	4	4.5	2	1.5	22.0	0.41	1.5	0.81	0.930			
HR 32212 J	3EC	72	68	101	95	104	4	5.5	2	1.5	24.1	0.41	1.5	0.81	1.18			
HR 33212 J	3EE	72	68	101	94	105	6	9	2	1.5	27.6	0.40	1.5	0.82	1.56			
T7 FC060	7FC	78	72	111	94	119	4	11	2.5	2.5	41.4	0.82	0.73	0.40	2.03			
HR 30312 J	2FB	78	77	118	112	120	4	7.5	2.5	2	26.0	0.35	1.7	0.96	2.03			
HR 30312 DJ	7FB	84	74	118	103	125	4	11.5	2.5	2	40.3	0.83	0.73	0.40	1.98			
HR 31312 J	7FB	84	74	118	103	125	4	11.5	2.5	2	40.3	0.83	0.73	0.40	1.98			
HR 32312 J	2FD	81	74	118	107	120	4	11.5	2.5	2	31.4	0.35	1.7	0.96	2.96			
32312 C	—	81	74	116	102	125	4	13.5	2.5	2	39.9	0.58	1.0	0.57	2.86			
HR 32913 J	2BC	74	70	84	82	86	4	3	1	1	16.8	0.35	1.7	0.93	0.323			
HR 32013 Xj	4CC	76	71	91	90	97	4	5.5	1.5	1.5	22.4	0.46	1.3	0.72	0.646			
HR 33013 J	2CE	76	71	91	90	96	5	6	1.5	1.5	21.1	0.35	1.7	0.95	0.76			
HR 33113 J	3DE	76	73	101	96	106	6	7.5	1.5	1.5	26.0	0.39	1.5	0.85	1.32			
HR 30213 J	3EB	77	78	111	106	113	4	4.5	2	1.5	23.8	0.41	1.5	0.81	1.18			
HR 32213 J	3EC	77	75	111	104	115	4	5.5	2	1.5	27.1	0.41	1.5	0.81	1.55			
HR 33213 J	3EE	77	74	111	102	115	6	9	2	1.5	29.2	0.39	1.5	0.85	2.04			
HR 30313 J	2GB	83	83	128	121	130	4	8	2.5	2	27.9	0.35	1.7	0.96	2.51			
HR 30313 DJ	7GB	89	80	128	111	133	4	13	2.5	2	43.2	0.83	0.73	0.40	2.43			
HR 31313 J	7GB	89	80	128	111	133	4	13	2.5	2	43.2	0.83	0.73	0.40	2.43			
HR 32313 J	2GD	86	80	128	116	130	4	12	2.5	2	34.0	0.35	1.7	0.96	3.6			

# Single-Row Tapered Roller Bearings

Bore Diameter 70 – 80 mm

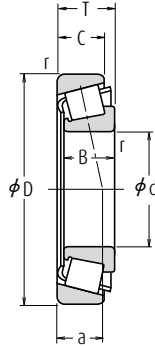

Boundary Dimensions (mm)							Basic Load Ratings (N) {kgf}				Limiting Speeds (min <sup>-1</sup> )		
d	D	T	B	C	Cone Cup		C <sub>r</sub>	C <sub>0r</sub>	C <sub>r</sub>	C <sub>0r</sub>	Grease	Oil	
					r	r min.							
70	100	20	20	16	1	1	70 000	113 000	7 150	11 500	3 200	4 500	
	110	25	25	19	1.5	1.5	104 000	158 000	10 600	16 100	3 200	4 300	
	110	31	31	25.5	1.5	1.5	127 000	204 000	12 900	20 800	3 000	4 300	
	120	37	37	29	2	1.5	177 000	262 000	18 100	26 700	3 000	4 000	
	125	26.25	24	21	2	1.5	132 000	163 000	13 500	16 700	2 800	4 000	
	125	33.25	31	27	2	1.5	157 000	205 000	16 100	20 900	2 800	4 000	
	125	41	41	32	2	1.5	209 000	299 000	21 300	30 500	2 800	4 000	
	140	39	35.5	27	3	3	177 000	229 000	18 000	23 400	2 400	3 400	
	150	38	35	30	3	2.5	227 000	268 000	23 200	27 400	2 400	3 400	
	150	38	35	25	3	2.5	192 000	229 000	19 600	23 300	2 200	3 200	
	150	38	35	25	3	2.5	192 000	229 000	19 600	23 300	2 200	3 200	
	150	54	51	42	3	2.5	300 000	390 000	30 500	39 500	2 600	3 400	
	150	54	51	42	3	2.5	280 000	390 000	28 600	39 500	2 400	3 400	
	75	105	20	20	16	1	1	72 500	120 000	7 400	12 300	3 200	4 300
115		25	25	19	1.5	1.5	109 000	171 000	11 100	17 400	3 000	4 000	
115		31	31	25.5	1.5	1.5	133 000	220 000	13 500	22 500	3 000	4 000	
125		37	37	29	2	2	182 000	275 000	18 600	28 100	2 800	3 800	
130		27.25	25	22	2	1.5	143 000	182 000	14 600	18 500	2 800	3 800	
130		33.25	31	27	2	1.5	165 000	219 000	16 900	22 400	2 800	3 800	
130		41	41	31	2	1.5	215 000	315 000	21 900	32 000	2 800	3 800	
160		40	37	31	3	2.5	253 000	300 000	25 800	30 500	2 400	3 200	
160		40	37	26	3	2.5	211 000	251 000	21 500	25 600	2 200	3 000	
160		40	37	26	3	2.5	211 000	251 000	21 500	25 600	2 200	3 000	
160		58	55	45	3	2.5	340 000	445 000	35 000	45 500	2 400	3 200	
160		58	55	43	3	2.5	310 000	420 000	32 000	43 000	2 200	3 200	
80		110	20	20	16	1	1	75 000	128 000	7 650	13 100	3 000	4 000
		125	29	29	22	1.5	1.5	140 000	222 000	14 300	22 700	2 800	3 600
	125	36	36	29.5	1.5	1.5	172 000	282 000	17 500	28 800	2 800	3 600	
	130	37	37	29	2	1.5	186 000	289 000	19 000	29 400	2 600	3 600	
	140	28.25	26	22	2.5	2	157 000	195 000	16 000	19 900	2 600	3 400	
	140	28.25	26	20	2.5	2	147 000	190 000	15 000	19 400	2 400	3 400	
	140	35.25	33	28	2.5	2	192 000	254 000	19 600	25 900	2 600	3 400	
	140	46	46	35	2.5	2	256 000	385 000	26 200	39 000	2 600	3 400	
	170	42.5	39	33	3	2.5	276 000	330 000	28 200	33 500	2 200	3 000	
	170	42.5	39	27	3	2.5	235 000	283 000	24 000	28 900	2 000	2 800	
	170	42.5	39	27	3	2.5	235 000	283 000	24 000	28 900	2 000	2 800	
	170	61.5	58	48	3	2.5	385 000	505 000	39 000	51 500	2 200	3 000	
	170	61.5	58	48	3	2.5	365 000	530 000	37 500	54 000	2 200	3 000	

**Remarks**

The suffix CA represents medium-angle tapered roller bearings. Since they are designed for specific applications, please consult NSK when using bearings with suffix CA.

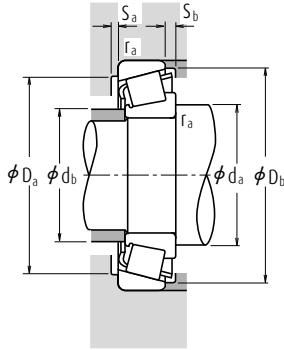

### Dynamic Equivalent Load $P = X F_r + Y F_a$

$F_a/F_r \leq e$		$F_a/F_r > e$	
X	Y	X	Y
1	0	0.4	$Y_1$

### Static Equivalent Load

$$P_0 = 0.5 F_r + Y_0 F_a$$

When  $F_r > 0.5 F_r + Y_0 F_a$ , use  $P_0 = F_r$

The values of  $e$ ,  $Y_1$  and  $Y_0$  are given in the table below.

Bearing Numbers	ISO355 Dimension Series	Abutment and Fillet Dimensions (mm)										Eff. Load Centers (mm)	Constant	Axial Load Factors		Mass (kg)			
		$d_a$ approx.	$d_b$ min.	$d_b$ max.	$D_a$ max.	$d_b$ min.	$S_a$ min.	$S_b$ min.	Cone		$r_a$ max.			a	e		$Y_1$	$Y_0$	approx.
									Cup	max.									
HR 32914 J	2BC	79	76	94	93	96	4	4	1	1	17.6	0.32	1.9	1.1	0.494				
HR 32014 XJ	4CC	81	77	101	98	105	5	6	1.5	1.5	23.7	0.43	1.4	0.76	0.869				
HR 33014 J	2CE	81	78	101	100	105	5	5.5	1.5	1.5	22.2	0.28	2.1	1.2	1.11				
HR 33114 J	3DE	82	79	111	104	115	6	8	2	1.5	27.9	0.38	1.6	0.87	1.71				
HR 30214 J	3EB	82	81	116	110	118	4	5	2	1.5	25.6	0.42	1.4	0.79	1.3				
HR 32214 J	3EC	82	80	116	108	119	4	6	2	1.5	28.6	0.42	1.4	0.79	1.66				
HR 33214 J	3EE	82	78	116	107	120	7	9	2	1.5	30.4	0.41	1.5	0.81	2.15				
T7 FC070	7FC	88	79	126	106	133	5	12	2.5	2.5	46.4	0.87	0.69	0.38	2.55				
HR 30314 J	2GB	88	89	138	132	140	4	8	2.5	2	29.7	0.35	1.7	0.96	3.03				
HR 30314 DJ	7GB	94	85	138	118	142	4	13	2.5	2	45.8	0.83	0.73	0.40	2.94				
HR 31314 J	7GB	94	85	138	118	142	4	13	2.5	2	45.8	0.83	0.73	0.40	2.94				
HR 32314 J	2GD	91	86	138	124	140	4	12	2.5	2	36.1	0.35	1.7	0.96	4.35				
HR 32314 CJ	5GD	91	84	138	115	141	4	12	2.5	2	43.3	0.55	1.1	0.60	4.47				
HR 32915 J	2BC	84	81	99	98	101	4	4	1	1	18.7	0.33	1.8	0.99	0.53				
HR 32015 XJ	4CC	86	82	106	103	110	5	6	1.5	1.5	25.1	0.46	1.3	0.72	0.925				
HR 33015 J	2CE	86	83	106	104	110	6	5.5	1.5	1.5	23.0	0.30	2.0	1.1	1.18				
HR 33115 J	3DE	87	83	115	109	120	6	8	2	2	29.2	0.40	1.5	0.83	1.8				
HR 30215 J	4DB	87	85	121	115	124	4	5	2	1.5	27.0	0.44	1.4	0.76	1.43				
HR 32215 J	4DC	87	84	121	113	125	4	6	2	1.5	29.8	0.44	1.4	0.76	1.72				
HR 33215 J	3EE	87	83	121	111	125	7	10	2	1.5	31.6	0.43	1.4	0.77	2.25				
HR 30315 J	2GB	93	95	148	141	149	4	9	2.5	2	31.8	0.35	1.7	0.96	3.63				
HR 30315 DJ	7GB	99	91	148	129	152	6	14	2.5	2	48.8	0.83	0.73	0.40	3.47				
HR 31315 J	7GB	99	91	148	129	152	6	14	2.5	2	48.8	0.83	0.73	0.40	3.47				
HR 32315 J	2GD	96	91	148	134	149	4	13	2.5	2	38.9	0.35	1.7	0.96	5.31				
32315 CA	—	96	90	148	124	153	4	15	2.5	2	47.7	0.58	1.0	0.57	5.3				
HR 32916 J	2BC	89	85	104	102	106	4	4	1	1	19.8	0.35	1.7	0.94	0.56				
HR 32016 XJ	3CC	91	89	116	112	120	6	7	1.5	1.5	26.9	0.42	1.4	0.78	1.32				
HR 33016 J	2CE	91	88	116	112	119	6	6.5	1.5	1.5	25.5	0.28	2.2	1.2	1.66				
HR 33116 J	3DE	82	88	121	113	126	6	8	2	1.5	30.4	0.42	1.4	0.79	1.88				
HR 30216 J	3EB	95	91	130	124	132	4	6	2	2	28.1	0.42	1.4	0.79	1.68				
30216 CA	—	95	92	130	122	133	4	8	2	2	33.8	0.58	1.0	0.57	1.66				
HR 32216 J	3EC	95	90	130	122	134	4	7	2	2	30.6	0.42	1.4	0.79	2.13				
HR 33216 J	3EE	95	89	130	119	135	7	11	2	2	34.8	0.43	1.4	0.78	2.93				
HR 30316 J	2GB	98	102	158	150	159	4	9.5	2.5	2	34.0	0.35	1.7	0.96	4.27				
HR 30316 DJ	7GB	104	97	158	136	159	6	15.5	2.5	2	51.8	0.83	0.73	0.40	4.07				
HR 31316 J	7GB	104	97	158	136	159	6	15.5	2.5	2	51.8	0.83	0.73	0.40	4.07				
HR 32316 J	2GD	101	98	158	143	159	4	13.5	2.5	2	41.4	0.35	1.7	0.96	6.35				
HR 32316 CJ	5GD	101	95	158	132	160	4	13.5	2.5	2	49.3	0.55	1.1	0.60	6.59				



# Single-Row Tapered Roller Bearings

Bore Diameter 85 – 95 mm

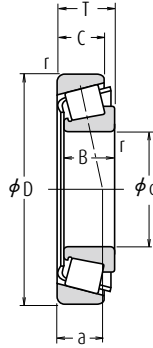

d	Boundary Dimensions (mm)					Cone		Basic Load Ratings (N)				Limiting Speeds (min <sup>-1</sup> )	
	D	T	B	C	r	Cup	C <sub>r</sub>	C <sub>0r</sub>	C <sub>r</sub>	C <sub>0r</sub>	Grease	Oil	
85	120	23	23	18	1.5	1.5	93 500	157 000	9 550	16 000	2 800	3 800	
	130	29	29	22	1.5	1.5	143 000	231 000	14 600	23 600	2 600	3 600	
	130	36	36	29.5	1.5	1.5	180 000	305 000	18 400	31 000	2 600	3 600	
	140	41	41	32	2.5	2	230 000	365 000	23 500	37 000	2 400	3 400	
	150	30.5	28	24	2.5	2	184 000	233 000	18 700	23 800	2 400	3 200	
	150	30.5	28	22	2.5	2	171 000	226 000	17 500	23 000	2 200	3 200	
	150	38.5	36	30	2.5	2	210 000	277 000	21 400	28 200	2 200	3 200	
	150	49	49	37	2.5	2	281 000	415 000	28 700	42 500	2 400	3 200	
	180	44.5	41	34	4	3	310 000	375 000	31 500	38 000	2 000	2 800	
	180	44.5	41	28	4	3	261 000	315 000	26 600	32 000	1 900	2 600	
	180	44.5	41	28	4	3	261 000	315 000	26 600	32 000	1 900	2 600	
	180	63.5	60	49	4	3	410 000	535 000	42 000	54 500	2 000	2 800	
90	125	23	23	18	1.5	1.5	97 000	167 000	9 850	17 000	2 600	3 600	
	140	32	32	24	2	1.5	170 000	273 000	17 300	27 800	2 400	3 200	
	140	39	39	32.5	2	1.5	220 000	360 000	22 400	37 000	2 400	3 200	
	150	45	45	35	2.5	2	259 000	405 000	26 500	41 500	2 400	3 200	
	160	32.5	30	26	2.5	2	201 000	256 000	20 500	26 100	2 200	3 000	
	160	42.5	40	34	2.5	2	256 000	350 000	26 100	35 500	2 200	3 000	
	190	46.5	43	36	4	3	345 000	425 000	35 500	43 000	1 900	2 600	
	190	46.5	43	30	4	3	264 000	315 000	26 900	32 000	1 800	2 400	
	190	46.5	43	30	4	3	264 000	315 000	26 900	32 000	1 800	2 400	
	190	67.5	64	53	4	3	450 000	590 000	46 000	60 500	2 000	2 600	
	95	130	23	23	18	1.5	1.5	98 000	172 000	10 000	17 500	2 400	3 400
		145	32	32	24	2	1.5	173 000	283 000	17 600	28 900	2 400	3 200
145		39	39	32.5	2	1.5	231 000	390 000	23 500	39 500	2 400	3 200	
160		46	46	38	3	3	283 000	445 000	28 800	45 500	2 200	3 000	
170		34.5	32	27	3	2.5	223 000	286 000	22 800	29 200	2 200	2 800	
170		45.5	43	37	3	2.5	289 000	400 000	29 500	40 500	2 200	2 800	
200		49.5	45	38	4	3	370 000	455 000	38 000	46 500	1 900	2 600	
200		49.5	45	36	4	3	350 000	435 000	35 500	44 000	1 800	2 400	
200		49.5	45	32	4	3	310 000	375 000	31 500	38 500	1 700	2 400	
200		49.5	45	32	4	3	310 000	375 000	31 500	38 500	1 700	2 400	
200		71.5	67	55	4	3	525 000	710 000	53 500	72 500	1 900	2 600	

**Remarks**

The suffix CA represents medium-angle tapered roller bearings. Since they are designed for specific applications, please consult NSK when using bearings with suffix CA.

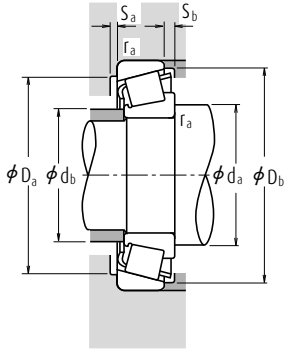

### Dynamic Equivalent Load $P=XF_r+YF_a$

$F_a/F_r \leq e$		$F_a/F_r > e$	
X	Y	X	Y
1	0	0.4	$Y_1$

### Static Equivalent Load

$$P_0=0.5F_r+Y_0F_a$$

When  $F_r > 0.5F_r+Y_0F_a$ , use  $P_0=F_r$

The values of  $e$ ,  $Y_1$  and  $Y_0$  are given in the table below.

Bearing Numbers	ISO355 Dimension Series	Abutment and Fillet Dimensions (mm)										Eff. Load Centers (mm)	Constant	Axial Load Factors		Mass (kg)	
		$d_b$		$D_a$		$S_a$		Cone		$r_a$	a			e	$Y_1$		$Y_0$
		min.	max.	max.	min.	min.	min.	max.	max.								
HR 32917 J	2BC	96	92	111	111	115	5	5	1.5	1.5	20.9	0.33	1.8	1.0	0.8		
HR 32017 XJ	4CC	96	94	121	116	125	6	7	1.5	1.5	28.2	0.44	1.4	0.75	1.38		
HR 33017 J	2CE	96	94	121	117	125	6	6.5	1.5	1.5	26.5	0.29	2.1	1.1	1.75		
HR 33117 J	3DE	100	94	130	122	135	7	9	2	2	32.7	0.41	1.5	0.81	2.51		
HR 30217 J	3EB	100	97	140	133	141	5	6.5	2	2	30.3	0.42	1.4	0.79	2.12		
30217 CA	—	100	98	140	131	142	5	8.5	2	2	36.2	0.58	1.0	0.57	2.07		
HR 32217 J	3EC	100	96	140	131	142	5	8.5	2	2	33.9	0.42	1.4	0.79	2.64		
HR 33217 J	3EE	100	95	140	129	144	7	12	2	2	37.3	0.42	1.4	0.79	3.57		
HR 30317 J	2GB	106	108	166	157	167	5	10.5	3	2.5	35.8	0.35	1.7	0.96	5.08		
HR 30317 DJ	7GB	113	103	166	144	169	6	16.5	3	2.5	55.4	0.83	0.73	0.40	4.88		
HR 31317 J	7GB	113	103	166	144	169	6	16.5	3	2.5	55.4	0.83	0.73	0.40	4.88		
HR 32317 J	2GD	110	104	166	151	167	5	14.5	3	2.5	43.6	0.35	1.7	0.96	7.31		
HR 32918 J	2BC	101	97	116	116	120	5	5	1.5	1.5	22.0	0.34	1.8	0.96	0.838		
HR 32018 XJ	3CC	102	99	131	124	134	6	8	2	1.5	29.7	0.42	1.4	0.78	1.78		
HR 33018 J	2CE	102	99	131	129	135	7	6.5	2	1.5	27.9	0.27	2.2	1.2	2.21		
HR 33118 J	3DE	105	100	140	132	144	7	10	2	2	35.2	0.40	1.5	0.83	3.14		
HR 30218 J	3FB	105	103	150	141	150	5	6.5	2	2	31.7	0.42	1.4	0.79	2.6		
HR 32218 J	3FC	105	102	150	139	152	5	8.5	2	2	36.2	0.42	1.4	0.79	3.41		
HR 30318 J	2GB	111	114	176	176	176	5	10.5	3	2.5	37.3	0.35	1.7	0.96	5.91		
HR 30318 DJ	7GB	118	110	176	152	179	6	16.5	3	2.5	58.7	0.83	0.73	0.40	5.52		
HR 31318 J	7GB	118	110	176	152	179	6	16.5	3	2.5	58.7	0.83	0.73	0.40	5.52		
HR 32318 J	2GD	115	109	176	158	177	5	14.5	3	2.5	46.5	0.35	1.7	0.96	8.6		
HR 32919 J	2BC	106	102	121	121	125	5	5	1.5	1.5	23.2	0.36	1.7	0.92	0.877		
HR 32019 XJ	4CC	107	104	136	131	140	6	8	2	1.5	31.2	0.44	1.4	0.75	1.88		
HR 33019 J	2CE	107	103	136	133	139	7	6.5	2	1.5	28.6	0.28	2.2	1.2	2.3		
T2 ED095	2ED	113	108	146	141	152	6	8	2.5	2.5	34.5	0.34	1.8	0.97	3.74		
HR 30219 J	3FB	113	110	158	150	159	5	7.5	2.5	2	33.7	0.42	1.4	0.79	3.13		
HR 32219 J	3FC	113	108	158	147	161	5	8.5	2.5	2	39.3	0.42	1.4	0.79	4.22		
HR 30319 J	2GB	116	119	186	172	184	5	11.5	3	2.5	38.6	0.35	1.7	0.96	6.92		
30319 CA	—	116	119	186	168	188	5	13.5	3	2.5	48.6	0.54	1.1	0.61	6.71		
HR 30319 DJ	7GB	123	115	186	158	187	6	17.5	3	2.5	61.9	0.83	0.73	0.40	6.64		
HR 31319 J	7GB	123	115	186	158	187	6	17.5	3	2.5	61.9	0.83	0.73	0.40	6.64		
HR 32319 J	2GD	120	115	186	167	186	5	16.5	3	2.5	48.6	0.35	1.7	0.96	10.4		

# Single-Row Tapered Roller Bearings

Bore Diameter 100 – 120 mm

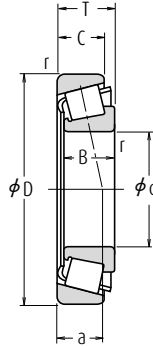

d	Boundary Dimensions (mm)					Cone		Cup		Basic Load Ratings (N) {kgf}				Limiting Speeds (min <sup>-1</sup> )	
	D	T	B	C	r min.	r min.	C <sub>r</sub>	C <sub>0r</sub>	C <sub>r</sub>	C <sub>0r</sub>	Grease	Oil			
100	140	25	25	20	1.5	1.5	117 000	205 000	12 000	20 900	2 200	3 200			
	145	24	22.5	17.5	3	3	113 000	163 000	11 500	16 600	2 200	3 000			
	150	32	32	24	2	1.5	176 000	294 000	17 900	30 000	2 200	3 000			
	150	39	39	32.5	2	1.5	235 000	405 000	24 000	41 500	2 200	3 000			
	165	52	52	40	2.5	2	315 000	515 000	32 500	52 500	2 000	2 800			
	180	37	34	29	3	2.5	255 000	330 000	26 000	34 000	2 000	2 600			
	180	49	46	39	3	2.5	325 000	450 000	33 000	46 000	2 000	2 600			
	180	63	63	48	3	2.5	410 000	635 000	42 000	65 000	2 000	2 600			
	215	51.5	47	39	4	3	425 000	525 000	43 000	53 500	1 700	2 400			
	215	56.5	51	35	4	3	385 000	505 000	39 000	51 500	1 500	2 200			
215	77.5	73	60	4	3	565 000	755 000	57 500	77 000	1 700	2 400				
105	145	25	25	20	1.5	1.5	119 000	212 000	12 100	21 600	2 200	3 000			
	160	35	35	26	2.5	2	204 000	340 000	20 800	34 500	2 000	2 800			
	160	43	43	34	2.5	2	256 000	435 000	26 100	44 000	2 000	2 800			
	190	39	36	30	3	2.5	280 000	365 000	28 500	37 500	1 900	2 600			
	190	53	50	43	3	2.5	360 000	510 000	37 000	52 000	1 900	2 600			
	225	53.5	49	41	4	3	455 000	565 000	46 500	57 500	1 600	2 200			
	225	58	53	36	4	3	415 000	540 000	42 000	55 000	1 500	2 000			
	225	81.5	77	63	4	3	670 000	925 000	68 000	94 500	1 700	2 200			
	110	150	25	25	20	1.5	1.5	123 000	224 000	12 500	22 800	2 200	2 800		
		170	38	38	29	2.5	2	236 000	390 000	24 000	40 000	2 000	2 600		
170		47	47	37	2.5	2	294 000	515 000	30 000	52 500	2 000	2 600			
180		56	56	43	2.5	2	365 000	610 000	37 500	62 000	1 900	2 600			
200		41	38	32	3	2.5	315 000	420 000	32 000	43 000	1 800	2 400			
200		56	53	46	3	2.5	400 000	565 000	40 500	57 500	1 800	2 400			
240		54.5	50	42	4	3	485 000	595 000	49 500	60 500	1 500	2 000			
240		63	57	38	4	3	470 000	605 000	48 000	62 000	1 400	1 900			
240		84.5	80	65	4	3	675 000	910 000	68 500	93 000	1 500	2 000			
120		165	29	29	23	1.5	1.5	161 000	291 000	16 400	29 700	1 900	2 600		
	170	27	25	19.5	3	3	153 000	243 000	51 600	24 800	1 800	2 600			
	180	38	38	29	2.5	2	242 000	405 000	24 600	41 000	1 800	2 400			
	180	48	48	38	2.5	2	300 000	540 000	30 500	55 000	1 800	2 600			
	200	62	62	48	2.5	2	460 000	755 000	46 500	77 000	1 700	2 400			
	215	43.5	40	34	3	2.5	335 000	450 000	34 000	46 000	1 600	2 200			
	215	61.5	58	50	3	2.5	440 000	635 000	44 500	65 000	1 600	2 200			
	260	59.5	55	46	4	3	535 000	655 000	54 500	67 000	1 400	1 900			
	260	68	62	42	4	3	560 000	730 000	57 000	74 500	1 300	1 800			
	260	90.5	86	69	4	3	770 000	1 060 000	78 500	108 000	1 400	1 900			

**Remarks** The suffix CA represents medium-angle tapered roller bearings. Since they are designed for specific applications, please consult NSK when using bearings with suffix CA.

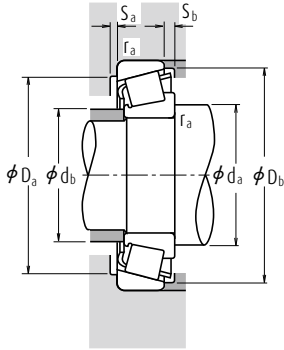

### Dynamic Equivalent Load $P = X F_r + Y F_a$

$F_a/F_r \leq e$		$F_a/F_r > e$	
X	Y	X	Y
1	0	0.4	$Y_1$

### Static Equivalent Load

$$P_0 = 0.5 F_r + Y_0 F_a$$

When  $F_r > 0.5 F_r + Y_0 F_a$ , use  $P_0 = F_r$

The values of  $e$ ,  $Y_1$  and  $Y_0$  are given in the table below.

Bearing Numbers	ISO355 Dimension Series	Abutment and Fillet Dimensions (mm)									Eff. Load Centers (mm)	Constant	Axial Load Factors		Mass (kg)			
		$d_a$ approx.	$d_b$ min.	$d_b$ max.	$D_a$ max.	$D_b$ min.	$S_a$ min.	$S_b$ min.	Cone Cup				a	e		$Y_1$	$Y_0$	approx.
									$r_a$ min.	$r_a$ max.								
HR 32920 J	2CC	111	109	132	132	134	5	5	1.5	1.5	24.2	0.33	1.8	1.0	1.18			
T4 CB100	4CB	118	108	135	135	142	6	6.5	2.5	2.5	30.1	0.47	1.3	0.70	1.18			
HR 32020 XJ	4CC	112	109	141	136	144	6	8	2	1.5	32.5	0.46	1.3	0.72	1.95			
HR 33020 J	2CE	112	107	141	137	143	7	6.5	2	1.5	29.3	0.29	2.1	1.2	2.38			
HR 33120 J	3EE	115	110	155	144	159	8	12	2	2	40.5	0.41	1.5	0.81	4.32			
HR 30220 J	3FB	118	116	168	158	168	5	8	2.5	2	36.1	0.42	1.4	0.79	3.78			
HR 32220 J	3FC	118	115	168	155	171	5	10	2.5	2	41.5	0.42	1.4	0.79	5.05			
HR 33220 J	3FE	118	113	168	152	172	10	15	2.5	2	46.0	0.40	1.5	0.82	6.76			
HR 30320 J	2GB	121	128	201	185	197	5	12.5	3	2.5	41.4	0.35	1.7	0.96	8.41			
HR 31320 J	7GB	136	125	201	169	202	7	21.5	3	2.5	67.7	0.83	0.73	0.40	9.02			
HR 32320 J	2GD	125	125	201	178	200	5	17.5	3	2.5	53.2	0.35	1.7	0.96	12.7			
HR 32921 J	2CC	116	114	137	137	140	5	5	1.5	1.5	25.3	0.34	1.8	0.96	1.23			
HR 32021 XJ	4DC	120	115	150	144	154	6	9	2	2	34.3	0.44	1.4	0.74	2.48			
HR 33021 J	2DE	120	115	150	146	153	7	9	2	2	30.9	0.28	2.1	1.2	3.03			
HR 30221 J	3FB	123	123	178	166	177	6	9	2.5	2	38.1	0.42	1.4	0.79	4.51			
HR 32221 J	3FC	123	120	178	162	180	5	10	2.5	2	44.8	0.42	1.4	0.79	6.25			
HR 30321 J	2GB	126	133	211	195	206	6	12.5	3	2.5	43.3	0.35	1.7	0.96	9.52			
HR 31321 J	7GB	141	130	211	177	211	7	22	3	2.5	70.2	0.83	0.73	0.40	10			
HR 32321 J	2GD	130	129	211	186	209	6	18.5	3	2.5	55.2	0.35	1.7	0.96	14.9			
HR 32922 J	2CC	121	119	142	142	145	5	5	1.5	1.5	26.5	0.36	1.7	0.93	1.29			
HR 32022 XJ	4DC	125	121	160	153	163	7	9	2	2	35.9	0.43	1.4	0.77	3.09			
HR 33022 J	2DE	125	121	160	153	161	7	10	2	2	33.7	0.29	2.1	1.2	3.84			
HR 33122 J	3EE	125	121	170	156	174	9	13	2	2	44.1	0.42	1.4	0.79	5.54			
HR 30222 J	3FB	128	129	188	175	187	6	9	2.5	2	40.2	0.42	1.4	0.79	5.28			
HR 32222 J	3FC	128	127	188	171	190	5	10	2.5	2	47.2	0.42	1.4	0.79	7.35			
HR 30322 J	2GB	131	143	226	208	220	6	12.5	3	2.5	45.1	0.35	1.7	0.96	11			
HR 31322 J	7GB	146	136	226	191	224	7	25	3	2.5	74.8	0.83	0.73	0.40	12.3			
HR 32322 J	2GD	135	139	226	201	222	6	19.5	3	2.5	58.6	0.35	1.7	0.96	17.1			
HR 32924 J	2CC	131	129	156	155	160	6	6	1.5	1.5	29.2	0.35	1.7	0.95	1.8			
T4 CB120	4CB	138	129	158	158	164	7	7.5	2.5	2.5	35.0	0.47	1.3	0.70	1.78			
HR 32024 XJ	4DC	135	131	170	162	173	7	9	2	2	39.7	0.46	1.3	0.72	3.27			
HR 33024 J	2DE	135	130	168	161	171	6	10	2	2	36.0	0.31	2.0	1.1	4.2			
HR 33124 J	3FE	135	133	190	173	192	9	14	2	2	47.9	0.40	1.5	0.83	7.67			
HR 30224 J	4FB	138	141	203	190	201	6	9.5	2.5	2	44.4	0.44	1.4	0.76	6.28			
HR 32224 J	4FD	138	137	203	181	204	6	11.5	2.5	2	52.1	0.44	1.4	0.76	9.0			
HR 30324 J	2GB	141	154	246	223	237	6	13.5	3	2.5	50.0	0.35	1.7	0.96	13.9			
HR 31324 J	7GB	156	148	246	206	244	9	26	3	2.5	81.7	0.83	0.73	0.40	15.6			
HR 32324 J	2GD	145	149	246	216	239	6	21.5	3	2.5	62.5	0.35	1.7	0.96	21.8			

# Single-Row Tapered Roller Bearings

Bore Diameter 130 – 160 mm

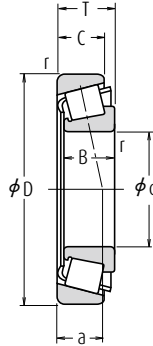

d	Boundary Dimensions (mm)					Cone		Cup		Basic Load Ratings (N) {kgf}				Limiting Speeds (min <sup>-1</sup> )	
	D	T	B	C	r	r	r	r	C <sub>r</sub>	C <sub>0r</sub>	C <sub>r</sub>	C <sub>0r</sub>	Grease	Oil	
130	180	32	30	26	2	1.5	167 000	281 000	17 000	28 600	1 800	2 400	1 800	2 400	
	180	32	32	25	2	1.5	200 000	365 000	20 400	37 500	1 800	2 400	1 800	2 400	
	185	29	27	21	3	3	183 000	296 000	18 600	30 000	1 700	2 400	1 700	2 400	
	200	45	45	34	2.5	2	320 000	535 000	32 500	54 500	1 600	2 200	1 600	2 200	
	200	55	55	43	2.5	2	395 000	715 000	40 500	73 000	1 700	2 200	1 700	2 200	
	230	43.75	40	34	4	3	375 000	505 000	38 000	51 500	1 500	2 000	1 500	2 000	
	230	67.75	64	54	4	3	530 000	790 000	54 000	80 500	1 500	2 000	1 500	2 000	
	280	63.75	58	49	5	4	545 000	675 000	56 000	68 500	1 300	1 800	1 300	1 800	
	280	63.75	58	49	5	4	650 000	820 000	66 000	83 500	1 300	1 800	1 300	1 800	
	280	72	66	44	5	4	625 000	820 000	63 500	83 500	1 200	1 700	1 200	1 700	
	280	98.75	93	78	5	4	830 000	1 150 000	84 500	117 000	1 300	1 800	1 300	1 800	
	140	190	32	32	25	2	1.5	206 000	390 000	21 000	39 500	1 700	2 200	1 700	2 200
210		45	45	34	2.5	2	325 000	555 000	33 000	57 000	1 600	2 200	1 600	2 200	
210		56	56	44	2.5	2	410 000	770 000	42 000	78 500	1 600	2 200	1 600	2 200	
250		45.75	42	36	4	3	390 000	515 000	40 000	52 500	1 400	1 900	1 400	1 900	
250		71.75	68	58	4	3	610 000	915 000	62 000	93 500	1 400	1 900	1 400	1 900	
300		67.75	62	53	5	4	740 000	945 000	75 500	96 500	1 200	1 700	1 200	1 700	
300		77	70	47	5	4	695 000	955 000	71 000	97 500	1 100	1 500	1 100	1 500	
300		107.75	102	85	5	4	985 000	1 440 000	101 000	147 000	1 200	1 600	1 200	1 600	
210		38	36	31	2.5	2	247 000	440 000	25 200	45 000	1 500	2 000	1 500	2 000	
210		38	38	30	2.5	2	281 000	520 000	28 600	53 000	1 500	2 000	1 500	2 000	
225		48	48	36	3	2.5	375 000	650 000	38 000	66 500	1 400	2 000	1 400	2 000	
225		59	59	46	3	2.5	435 000	805 000	44 000	82 000	1 400	2 000	1 400	2 000	
270	49	45	38	4	3	485 000	665 000	49 000	67 500	1 300	1 800	1 300	1 800		
270	77	73	60	4	3	705 000	1 080 000	71 500	110 000	1 300	1 800	1 300	1 800		
320	72	65	55	5	4	690 000	860 000	70 000	87 500	1 100	1 500	1 100	1 500		
320	72	65	55	5	4	825 000	1 060 000	84 500	108 000	1 100	1 600	1 100	1 600		
320	82	75	50	5	4	790 000	1 100 000	80 500	112 000	1 000	1 400	1 000	1 400		
320	114	108	90	5	4	1 120 000	1 700 000	114 000	174 000	1 100	1 500	1 100	1 500		
160	220	38	38	30	2.5	2	296 000	570 000	30 000	58 000	1 400	1 900	1 400	1 900	
	240	51	51	38	3	2.5	425 000	750 000	43 500	76 500	1 300	1 800	1 300	1 800	
	290	52	48	40	4	3	530 000	730 000	54 000	74 500	1 200	1 600	1 200	1 600	
	290	84	80	67	4	3	795 000	1 220 000	81 000	125 000	1 200	1 600	1 200	1 600	
	340	75	68	58	5	4	765 000	960 000	78 000	98 000	1 000	1 400	1 000	1 400	
	340	75	68	58	5	4	870 000	1 110 000	89 000	113 000	1 100	1 400	1 100	1 400	
	340	75	68	48	5	4	675 000	875 000	69 000	89 000	950	1 300	950	1 300	
	340	121	114	95	5	4	1 210 000	1 770 000	123 000	181 000	1 000	1 400	1 000	1 400	

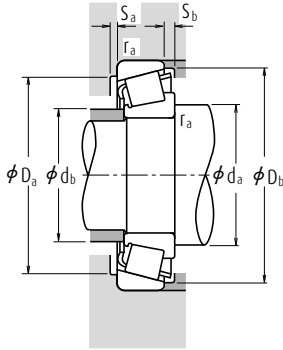

### Dynamic Equivalent Load $P = X F_r + Y F_a$

$F_a/F_r \leq e$		$F_a/F_r > e$	
X	Y	X	Y
1	0	0.4	$Y_1$

### Static Equivalent Load

$$P_0 = 0.5 F_r + Y_0 F_a$$

When  $F_r > 0.5 F_r + Y_0 F_a$ , use  $P_0 = F_r$

The values of  $e$ ,  $Y_1$  and  $Y_0$  are given in the table below.

Bearing Numbers	ISO355 Dimension Series	Abutment and Fillet Dimensions (mm)										Eff. Load Centers (mm)	Constant	Axial Load Factors		Mass (kg)	
		$d_b$		$D_a$		$S_a$		Cone		$r_a$	a			e	$Y_1$		$Y_0$
		min.	max.	max.	min.	min.	min.	min.	max.								
32926	—	142	141	171	168	175	6	6	2	1.5	34.7	0.36	1.7	0.92	2.25		
HR 32926 J	2CC	142	140	170	168	173	6	7	2	1.5	31.4	0.34	1.8	0.97	2.46		
T4 CB130	4CB	148	141	171	171	179	8	8	2.5	2.5	37.5	0.47	1.3	0.70	2.32		
HR 32026 XJ	4EC	145	144	190	179	192	8	11	2	2	43.9	0.43	1.4	0.76	5.06		
HR 33026 J	2EE	145	144	188	179	192	8	12	2	2	42.4	0.34	1.8	0.97	6.25		
HR 30226 J	4FB	151	151	216	205	217	7	9.5	3	2.5	45.9	0.44	1.4	0.76	7.25		
HR 32226 J	4FD	151	147	216	196	219	7	13.5	3	2.5	57.0	0.44	1.4	0.76	11.3		
30326	—	157	168	262	239	255	8	14.5	4	3	53.9	0.36	1.7	0.92	16.6		
HR 30326 J	2GB	157	166	262	241	255	8	14.5	4	3	52.8	0.35	1.7	0.96	17.2		
HR 31326 J	7GB	174	159	262	220	261	9	28	4	3	87.1	0.83	0.73	0.40	18.8		
32326	—	162	165	262	233	263	8	20.5	4	3	69.2	0.36	1.7	0.92	26.6		
HR 32928 J	2CC	152	150	180	178	184	6	7	2	1.5	33.6	0.36	1.7	0.92	2.64		
HR 32028 XJ	4DC	155	152	200	189	202	8	11	2	2	46.6	0.46	1.3	0.72	5.32		
HR 33028 J	2DE	155	153	198	189	202	7	12	2	2	45.5	0.36	1.7	0.92	6.74		
HR 30228 J	4FB	161	164	236	221	234	7	9.5	3	2.5	48.9	0.44	1.4	0.76	8.74		
HR 32228 J	4FD	161	159	236	213	238	9	13.5	3	2.5	60.5	0.44	1.4	0.76	14.3		
HR 30328 J	2GB	167	177	282	256	273	9	14.5	4	3	55.7	0.35	1.7	0.96	21.1		
HR 31328 J	7GB	184	174	282	236	280	9	30	4	3	92.9	0.83	0.73	0.40	28.5		
32328	—	172	177	282	246	281	9	22.5	4	3	76.4	0.37	1.6	0.88	33.9		
32930	—	165	162	200	195	201	7	7	2	2	36.7	0.33	1.8	1.0	3.8		
HR 32930 J	2DC	165	163	198	196	202	7	8	2	2	36.5	0.33	1.8	1.0	4.05		
HR 32030 XJ	4EC	168	164	213	202	216	8	12	2.5	2	49.8	0.46	1.3	0.72	6.6		
HR 33030 J	2EE	168	165	213	203	217	8	13	2.5	2	48.7	0.36	1.7	0.90	8.07		
HR 30230 J	2GB	171	175	256	236	250	7	11	3	2.5	51.3	0.44	1.4	0.76	11.2		
HR 32230 J	4GD	171	171	256	228	254	8	17	3	2.5	64.7	0.44	1.4	0.76	17.8		
30330	—	177	193	302	275	292	8	17	4	3	61.4	0.36	1.7	0.92	24.2		
HR 30330 J	2GB	177	190	302	276	292	8	17	4	3	60.0	0.35	1.7	0.96	25		
HR 31330 J	7GB	194	187	302	253	300	9	32	4	3	99.3	0.83	0.73	0.40	28.5		
32330	—	182	191	302	262	297	8	24	4	3	81.5	0.37	1.6	0.88	41.4		
HR 32932 J	2DC	175	173	208	206	212	7	8	2	2	38.7	0.35	1.7	0.95	4.32		
HR 32032 XJ	4EC	178	175	228	216	231	8	13	2.5	2	53.0	0.46	1.3	0.72	7.93		
HR 30232 J	4GB	181	189	276	253	269	8	12	3	2.5	55.0	0.44	1.4	0.76	13.7		
HR 32232 J	4GD	181	184	276	243	274	10	17	3	2.5	70.5	0.44	1.4	0.76	22.7		
30332	—	187	205	322	293	311	10	17	4	3	64.6	0.36	1.7	0.92	28.4		
HR 30332 J	2GB	187	201	322	293	310	10	17	4	3	62.9	0.35	1.7	0.96	29.2		
30332 D	—	196	198	322	270	313	9	27	4	3	99.4	0.81	0.74	0.41	27.5		
32332	—	192	202	322	281	319	10	26	4	3	87.1	0.37	1.6	0.88	48.3		

# Single-Row Tapered Roller Bearings

Bore Diameter 170 - 220 mm

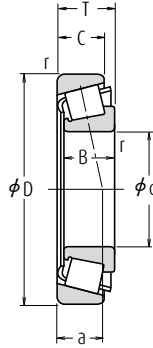

Boundary Dimensions (mm)							Basic Load Ratings (N) {kgf}				Limiting Speeds (min <sup>-1</sup> )	
d	D	T	B	C	Cone Cup		C <sub>r</sub>	C <sub>or</sub>	C <sub>r</sub>	C <sub>or</sub>	Grease	Oil
					r	r min.						
170	230	38	36	31	2.5	2.5	258 000	485 000	26 300	49 500	1 300	1 800
	230	38	38	30	2.5	2	294 000	560 000	30 000	57 000	1 400	1 800
	260	57	57	43	3	2.5	505 000	890 000	51 500	90 500	1 200	1 700
	310	57	52	43	5	4	630 000	885 000	64 000	90 000	1 100	1 500
	310	91	86	71	5	4	930 000	1 450 000	94 500	148 000	1 100	1 500
	360	80	72	62	5	4	845 000	1 080 000	86 000	110 000	950	1 300
	360	80	72	62	5	4	960 000	1 230 000	98 000	125 000	1 000	1 300
	360	80	72	50	5	4	760 000	1 040 000	77 500	106 000	900	1 200
180	360	127	120	100	5	4	1 370 000	2 050 000	140 000	209 000	1 000	1 300
	250	45	45	34	2.5	2	350 000	685 000	36 000	69 500	1 300	1 700
	280	64	64	48	3	2.5	640 000	1 130 000	65 000	115 000	1 200	1 600
	320	57	52	43	5	4	650 000	930 000	66 000	95 000	1 100	1 400
	320	91	86	71	5	4	960 000	1 540 000	98 000	157 000	1 100	1 400
	380	83	75	64	5	4	935 000	1 230 000	95 500	126 000	900	1 300
	380	83	75	53	5	4	820 000	1 120 000	83 500	114 000	850	1 200
	380	134	126	106	5	4	1 520 000	2 290 000	155 000	234 000	950	1 300
190	260	45	45	34	2.5	2	365 000	715 000	37 000	73 000	1 200	1 600
	290	64	64	48	3	2.5	650 000	1 170 000	66 000	119 000	1 100	1 500
	340	60	55	46	5	4	715 000	1 020 000	73 000	104 000	1 000	1 300
	340	97	92	75	5	4	1 110 000	1 770 000	113 000	181 000	1 000	1 400
	400	86	78	65	6	5	1 010 000	1 340 000	103 000	136 000	850	1 200
	400	140	132	109	6	5	1 660 000	2 580 000	169 000	263 000	850	1 200
200	280	51	48	41	3	2.5	410 000	780 000	42 000	80 000	1 100	1 500
	280	51	51	39	3	2.5	480 000	935 000	48 500	95 000	1 100	1 500
	310	70	70	53	3	2.5	760 000	1 370 000	77 500	139 000	1 000	1 400
	360	64	58	48	5	4	795 000	1 120 000	81 000	114 000	950	1 300
	360	104	98	82	5	4	1 210 000	1 920 000	123 000	196 000	950	1 300
	420	89	80	67	6	5	1 030 000	1 390 000	105 000	142 000	850	1 200
	420	89	80	56	6	5	965 000	1 330 000	98 500	136 000	750	1 000
	420	146	138	115	6	5	1 820 000	2 870 000	185 000	292 000	800	1 100
220	300	51	51	39	3	2.5	490 000	990 000	50 000	101 000	1 000	1 400
	340	76	76	57	4	3	885 000	1 610 000	90 500	164 000	950	1 300
	400	72	65	54	5	4	810 000	1 150 000	82 500	117 000	850	1 100
	400	114	108	90	5	4	1 340 000	2 210 000	137 000	225 000	850	1 100
	460	97	88	73	6	5	1 430 000	1 990 000	146 000	203 000	750	1 000
	460	154	145	122	6	5	2 020 000	3 200 000	206 000	325 000	750	1 000

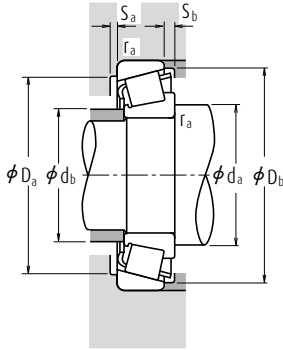

### Dynamic Equivalent Load $P=XF_r+YF_a$

$F_a/F_r \leq e$		$F_a/F_r > e$	
X	Y	X	Y
1	0	0.4	$Y_1$

### Static Equivalent Load

$$P_0=0.5F_r+Y_0F_a$$

When  $F_r > 0.5F_r+Y_0F_a$ , use  $P_0=F_r$

The values of  $e$ ,  $Y_1$  and  $Y_0$  are given in the table below.

Bearing Numbers	ISO355 Dimension Series	Abutment and Fillet Dimensions (mm)										Eff. Load Centers (mm)	Constant	Axial Load Factors		Mass (kg)	
		$d_b$		$D_a$		$S_a$		Cone		$r_a$ max.	a			e	$Y_1$		$Y_0$
		min.	max.	max.	min.	min.	min.	max.	max.								
32934	—	185	183	220	216	223	7	7	2	2	41.6	0.36	1.7	0.90	4.3		
HR 32934 J	3DC	185	180	218	215	222	7	8	2	2	41.7	0.38	1.6	0.86	4.44		
HR 32034 XJ	4EC	188	187	248	232	249	10	14	2.5	2	56.6	0.44	1.4	0.74	10.6		
HR 30234 J	4GB	197	202	292	273	288	8	14	4	3	59.4	0.44	1.4	0.76	17.1		
HR 32234 J	4GD	197	197	292	262	294	10	20	4	3	76.4	0.44	1.4	0.76	28		
30334	—	197	221	342	312	332	10	18	4	3	70.1	0.37	1.6	0.90	33.5		
HR 30334 J	2GB	197	214	342	310	329	10	18	4	3	67.3	0.35	1.7	0.96	34.5		
30334 D	—	206	215	342	288	332	10	30	4	3	107.3	0.81	0.74	0.41	33.4		
32334	—	202	213	342	297	337	10	27	4	3	91.3	0.37	1.6	0.88	57		
HR 32936 J	4DC	195	192	240	227	241	8	11	2	2	53.9	0.48	1.3	0.69	6.56		
HR 32036 XJ	3FD	198	199	268	248	267	10	16	2.5	2	60.4	0.42	1.4	0.78	14.3		
HR 30236 J	4GB	207	210	302	281	297	9	14	4	3	61.8	0.45	1.3	0.73	17.8		
HR 32236 J	4GD	207	205	302	270	303	10	20	4	3	78.9	0.45	1.3	0.73	29.8		
30336	—	207	233	362	324	345	10	19	4	3	72.5	0.36	1.7	0.92	39.3		
30336 D	—	216	229	362	304	352	10	30	4	3	113.1	0.81	0.74	0.41	38.5		
32336	—	212	225	362	310	353	10	28	4	3	96.6	0.37	1.6	0.88	66.8		
HR 32938 J	4DC	205	201	250	237	251	8	11	2	2	55.3	0.48	1.3	0.69	6.83		
HR 32038 XJ	4FD	208	209	278	258	279	10	16	2.5	2	63.4	0.44	1.4	0.75	14.9		
HR 30238 J	4GB	217	223	322	302	318	9	14	4	3	65.6	0.44	1.4	0.76	21.4		
HR 32238 J	4GD	217	216	322	290	323	10	22	4	3	80.5	0.44	1.4	0.76	35.2		
30338	—	223	248	378	346	366	11	21	5	4	76.1	0.36	1.7	0.92	46		
32338	—	229	243	378	332	375	11	31	5	4	102.7	0.37	1.6	0.88	78.9		
32940	—	218	217	268	256	269	9	10	2.5	2	53.4	0.37	1.6	0.88	9.26		
HR 32940 J	3EC	218	216	268	258	271	9	12	2.5	2	54.2	0.39	1.5	0.84	9.65		
HR 32040 XJ	4FD	218	221	298	277	297	11	17	2.5	2	67.4	0.43	1.4	0.77	18.9		
HR 30240 J	4GB	227	236	342	318	336	10	16	4	3	69.1	0.44	1.4	0.76	25.5		
HR 32240 J	3GD	227	230	342	305	340	11	22	4	3	85.1	0.41	1.5	0.81	42.6		
30340	—	233	253	398	346	368	11	22	5	4	81.4	0.37	1.6	0.88	52.3		
30340 D	—	244	253	398	336	385	11	33	5	4	122.9	0.81	0.74	0.41	49.6		
32340	—	239	253	398	346	392	11	31	5	4	106.7	0.37	1.6	0.88	90.9		
HR 32944 J	3EC	238	235	288	278	293	9	12	2.5	2	59.2	0.43	1.4	0.78	10.3		
HR 32044 XJ	4FD	241	244	326	303	326	12	19	3	2.5	73.6	0.43	1.4	0.77	24.4		
30244	—	247	267	382	350	367	11	18	4	3	74.7	0.40	1.5	0.82	33.6		
32244	—	247	260	382	340	377	12	24	4	3	93.0	0.40	1.5	0.82	57.4		
30344	—	253	283	438	390	414	12	24	5	4	85.4	0.36	1.7	0.92	72.4		
32344	—	259	274	438	372	421	12	32	5	4	114.9	0.37	1.6	0.88	114		



# Single-Row Tapered Roller Bearings

Bore Diameter 240 – 440 mm

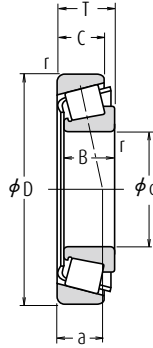

d	Boundary Dimensions (mm)					Cone		Basic Load Ratings (N)				Limiting Speeds (min <sup>-1</sup> )	
	D	T	B	C	r	Cup	C <sub>r</sub>	C <sub>0r</sub>	C <sub>r</sub>	C <sub>0r</sub>	Grease	Oil	
240	320	51	51	39	3	2,5	500 000	1 040 000	51 000	107 000	950	1 300	
	360	76	76	57	4	3	920 000	1 730 000	94 000	177 000	850	1 200	
	440	79	72	60	5	4	990 000	1 400 000	101 000	142 000	750	1 000	
	440	127	120	100	5	4	1 630 000	2 730 000	166 000	278 000	750	1 000	
	500	105	95	80	6	5	1 660 000	2 340 000	169 000	238 000	670	950	
260	500	165	155	132	6	5	2 520 000	4 100 000	257 000	415 000	670	900	
	360	63.5	63.5	48	3	2.5	730 000	1 450 000	74 500	148 000	850	1 100	
	400	87	87	65	5	4	1 160 000	2 160 000	118 000	220 000	800	1 100	
	480	89	80	67	6	5	1 190 000	1 700 000	121 000	174 000	670	900	
	480	137	130	106	6	5	1 900 000	3 300 000	194 000	335 000	670	950	
280	540	113	102	85	6	6	1 870 000	2 640 000	190 000	269 000	630	850	
	540	176	165	136	6	6	2 910 000	4 800 000	297 000	490 000	630	850	
	380	63.5	63.5	48	3	2.5	765 000	1 580 000	78 000	162 000	800	1 100	
	420	87	87	65	5	4	1 180 000	2 240 000	120 000	228 000	710	1 000	
	500	89	80	67	6	5	1 240 000	1 900 000	127 000	194 000	630	850	
300	500	137	130	106	6	5	1 950 000	3 450 000	199 000	355 000	630	850	
	580	187	175	145	6	6	3 300 000	5 400 000	335 000	550 000	560	800	
	420	76	72	62	4	3	895 000	1 820 000	91 000	186 000	710	950	
	420	76	76	57	4	3	1 010 000	2 100 000	103 000	214 000	710	950	
	460	100	100	74	5	4	1 440 000	2 700 000	147 000	275 000	670	900	
320	540	96	85	71	6	5	1 440 000	2 100 000	147 000	214 000	600	800	
	540	149	140	115	6	5	2 220 000	3 700 000	226 000	380 000	600	800	
	440	76	72	63	4	3	900 000	1 880 000	92 000	192 000	970	900	
	440	76	76	57	4	3	1 040 000	2 220 000	106 000	227 000	670	900	
	480	100	100	74	5	4	1 510 000	2 910 000	153 000	297 000	630	850	
340	580	104	92	75	6	5	1 640 000	2 420 000	168 000	247 000	530	750	
	580	159	150	125	6	5	2 860 000	5 050 000	292 000	515 000	530	750	
	670	210	200	170	7.5	7.5	4 200 000	7 100 000	430 000	725 000	480	670	
	460	76	72	63	4	3	910 000	1 940 000	93 000	197 000	630	850	
	460	76	76	57	4	3	1 050 000	2 220 000	107 000	226 000	630	850	
360	520	112	106	92	6	5	1 650 000	3 400 000	168 000	345 000	560	750	
	480	76	72	62	4	3	945 000	2 100 000	96 500	214 000	600	800	
	480	76	76	57	4	3	1 080 000	2 340 000	110 000	239 000	560	800	
	540	112	106	92	6	5	1 680 000	3 500 000	171 000	355 000	530	750	
	380	520	87	82	71	5	4	1 210 000	2 550 000	124 000	260 000	560	750
400	540	87	82	71	5	4	1 250 000	2 700 000	128 000	276 000	530	710	
	600	125	118	100	6	5	1 960 000	4 050 000	200 000	415 000	480	670	
	420	560	87	82	72	5	4	1 300 000	2 810 000	132 000	287 000	500	670
420	620	125	118	100	6	5	2 000 000	4 200 000	204 000	430 000	450	630	
	440	650	130	122	104	6	6	2 230 000	4 600 000	227 000	470 000	430	600

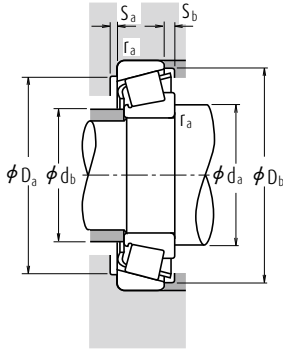

### Dynamic Equivalent Load $P = X F_r + Y F_a$

$F_a/F_r \leq e$		$F_a/F_r > e$	
X	Y	X	Y
1	0	0.4	$Y_1$

### Static Equivalent Load

$$P_0 = 0.5 F_r + Y_0 F_a$$

When  $F_r > 0.5 F_r + Y_0 F_a$ , use  $P_0 = F_r$

The values of  $e$ ,  $Y_1$  and  $Y_0$  are given in the table below.

Bearing Numbers	ISO355 Dimension Series	Abutment and Fillet Dimensions (mm)										Eff. Load Centers (mm)	Constant	Axial Load Factors		Mass (kg)	
		$d_b$		$D_a$		$S_a$		Cone		$r_a$ max.	a			e	$Y_1$		$Y_0$
		min.	max.	max.	min.	min.	min.	min.	max.								
HR 32948 J	4EC	258	255	308	297	314	9	12	2.5	2	65.1	0.46	1.3	0.72	11.1		
HR 32048 XJ	4FD	261	262	346	321	346	12	19	3	2.5	79.1	0.46	1.3	0.72	26.2		
30248	—	267	288	422	384	408	11	19	4	3	85.1	0.44	1.4	0.74	45.2		
32248	—	267	285	422	374	416	12	27	4	3	102.5	0.40	1.5	0.82	78		
30348	—	273	308	478	422	447	12	25	5	4	92.8	0.36	1.7	0.92	92.6		
32348	—	279	301	478	410	464	12	33	5	4	123.2	0.37	1.6	0.88	145		
HR 32952 J	3EC	278	278	348	333	347	11	15.5	2.5	2	69.8	0.41	1.5	0.81	18.6		
HR 32052 XJ	4FC	287	287	382	357	383	14	22	4	3	86.3	0.43	1.4	0.76	38.5		
30252	—	293	316	458	421	447	12	22	5	4	94.6	0.44	1.4	0.74	60.7		
32252	—	293	305	458	394	446	14	31	5	4	116.0	0.45	1.3	0.73	103		
30352	—	293	336	512	460	487	16	28	5	5	101.6	0.36	1.7	0.92	114		
32352	—	293	328	512	441	495	13	40	5	5	130.5	0.37	1.6	0.88	188		
HR 32956 J	4EC	298	297	368	352	368	12	15.5	2.5	2	75.3	0.43	1.4	0.76	20		
HR 32056 XJ	4FC	307	305	402	374	402	14	22	4	3	91.6	0.46	1.3	0.72	40.6		
30256	—	313	339	478	436	462	12	22	5	4	98.5	0.44	1.4	0.74	66.3		
32256	—	313	325	478	412	467	14	31	5	4	123.1	0.47	1.3	0.70	109		
32356	—	319	353	552	475	532	14	42	5	5	139.6	0.37	1.6	0.89	224		
32960	—	321	326	406	386	405	13	14	3	2.5	79.3	0.37	1.6	0.88	30.5		
HR 32960 J	3FD	321	324	406	387	405	13	19	3	2.5	79.9	0.39	1.5	0.84	31.4		
HR 32060 XJ	4GD	327	330	442	408	439	15	26	4	3	98.4	0.43	1.4	0.76	56.6		
30260	—	333	355	518	470	499	14	25	5	4	105.1	0.44	1.4	0.74	80.6		
32260	—	333	352	518	458	514	15	34	5	4	131.7	0.46	1.3	0.72	132		
32964	—	341	345	426	404	425	13	13	3	2.5	84.3	0.39	1.5	0.84	32		
HR 32964 J	3FD	341	344	426	406	426	13	19	3	2.5	85.0	0.42	1.4	0.79	33.3		
HR 32064 XJ	4GD	347	350	462	430	461	15	26	4	3	104.5	0.46	1.3	0.72	60		
30264	—	353	381	558	503	533	14	29	5	4	113.7	0.44	1.4	0.74	99.3		
32264	—	353	383	558	487	550	15	34	5	4	141.7	0.46	1.3	0.72	175		
32364	—	383	412	634	547	616	14	42	6	6	157.5	0.37	1.6	0.88	343		
32968	—	361	364	446	426	446	13	13	3	2.5	89.2	0.41	1.5	0.80	33.6		
HR 32968 J	4FD	361	362	446	427	446	13	19	3	2.5	91.0	0.44	1.4	0.75	34.3		
32068	—	373	386	498	464	496	3.5	22	5	4	104.5	0.37	1.6	0.89	83.7		
32972	—	381	386	466	445	465	14	14	3	2.5	91.4	0.40	1.5	0.82	35.8		
HR 32972 J	4FD	381	381	466	445	466	13	19	3	2.5	96.8	0.46	1.3	0.72	36.1		
32072	—	393	402	518	480	514	5.5	22	5	4	108.6	0.38	1.6	0.86	86.5		
32976	—	407	406	502	478	501	16	16	4	3	95.2	0.39	1.6	0.86	49.5		
32980	—	427	428	522	499	524	16	16	4	3	100.8	0.40	1.5	0.82	52.7		
32080	—	433	443	578	533	565	5	25	5	4	115.3	0.36	1.7	0.92	116		
32984	—	447	448	542	521	544	3.5	15	4	3	106.1	0.41	1.5	0.81	54.8		
32084	—	453	463	598	552	586	6.5	25	5	4	120.0	0.37	1.6	0.88	121		
32088	—	473	487	622	582	616	5	26	5	5	126.3	0.36	1.7	0.92	136		

# Single-Row Tapered Roller Bearings (Inch Design)

Bore Diameter 12.000 - 22.225 mm

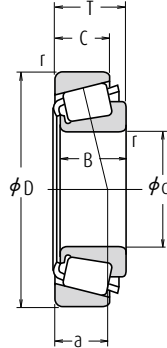

Boundary Dimensions (mm)							Basic Load Ratings (N) {kgf}				Limiting Speeds (min <sup>-1</sup> )	
d	D	T	B	C	Cone r min.	Cup r min.	C <sub>r</sub>	C <sub>or</sub>	C <sub>r</sub>	C <sub>or</sub>	Grease	Oil
12.000	31.991	10.008	10.785	7.938	0.8	1.3	10 300	8 900	1 050	905	13 000	18 000
12.700	34.988	10.998	10.988	8.730	1.3	1.3	11 700	10 900	1 200	1 110	12 000	16 000
15.000	34.988	10.998	10.988	8.730	0.8	1.3	11 700	10 900	1 200	1 110	12 000	16 000
15.875	34.988	10.998	10.998	8.712	1.3	1.3	13 800	13 400	1 410	1 360	11 000	15 000
	39.992	12.014	11.153	9.525	1.3	1.3	14 900	15 700	1 520	1 600	9 500	13 000
	41.275	14.288	14.681	11.112	1.3	2.0	21 300	19 900	2 170	2 030	10 000	13 000
	42.862	14.288	14.288	9.525	1.5	1.5	17 300	17 200	1 770	1 750	8 500	12 000
	42.862	16.670	16.670	13.495	1.5	1.5	26 900	26 300	2 750	2 680	9 500	13 000
	44.450	15.494	14.381	11.430	1.5	1.5	23 800	23 900	2 430	2 440	8 500	11 000
	49.225	19.845	21.539	14.288	0.8	1.3	37 500	37 000	3 800	3 800	8 500	11 000
16.000	47.000	21.000	21.000	16.000	1.0	2.0	35 000	36 500	3 600	3 750	9 000	12 000
16.993	39.992	12.014	11.153	9.525	0.8	1.3	14 900	15 700	1 520	1 600	9 500	13 000
17.455	36.525	11.112	11.112	7.938	1.5	1.5	11 600	11 000	1 190	1 120	10 000	14 000
17.462	39.878	13.843	14.605	10.668	1.3	1.3	22 500	22 500	2 290	2 290	10 000	13 000
	47.000	14.381	14.381	11.112	0.8	1.3	23 800	23 900	2 430	2 440	8 500	11 000
19.050	39.992	12.014	11.153	9.525	1.0	1.3	14 900	15 700	1 520	1 600	9 500	13 000
	45.237	15.494	16.637	12.065	1.3	1.3	28 500	28 900	2 910	2 950	9 000	12 000
	47.000	14.381	14.381	11.112	1.3	1.3	23 800	23 900	2 430	2 440	8 500	11 000
	49.225	18.034	19.050	14.288	1.3	1.3	37 500	37 000	3 800	3 800	8 500	11 000
	49.225	19.845	21.539	14.288	1.2	1.3	37 500	37 000	3 800	3 800	8 500	11 000
	49.225	21.209	19.050	17.462	1.3	1.5	37 500	37 000	3 800	3 800	8 500	11 000
	49.225	23.020	21.539	17.462	1.5	3.5	37 500	37 000	3 800	3 800	8 500	11 000
	53.975	22.225	21.839	15.875	1.5	2.3	40 500	39 500	4 150	4 000	7 500	10 000
19.990	47.000	14.381	14.381	11.112	1.5	1.3	23 800	23 900	2 430	2 440	8 500	11 000
20.000	51.994	15.011	14.260	12.700	1.5	1.3	26 000	27 900	2 650	2 840	7 500	10 000
20.625	49.225	23.020	21.539	17.462	1.5	1.5	37 500	37 000	3 800	3 800	8 500	11 000
20.638	49.225	19.845	19.845	15.875	1.5	1.5	36 000	37 000	3 650	3 750	8 000	11 000
21.430	50.005	17.526	18.288	13.970	1.3	1.3	38 500	40 000	3 950	4 100	8 000	11 000
22.000	45.237	15.494	16.637	12.065	1.3	1.3	29 200	33 500	2 980	3 400	8 500	11 000
	45.975	15.494	16.637	12.065	1.3	1.3	29 200	33 500	2 980	3 400	8 500	11 000
22.225	50.005	13.495	14.260	9.525	1.3	1.0	26 000	27 900	2 650	2 840	7 500	10 000
	50.005	17.526	18.288	13.970	1.3	1.3	38 500	40 000	3 950	4 100	8 000	11 000
	52.388	19.368	20.168	14.288	1.5	1.5	40 500	43 000	4 100	4 400	7 500	10 000
	53.975	19.368	20.168	14.288	1.5	1.5	40 500	43 000	4 100	4 400	7 500	10 000
	56.896	19.368	19.837	15.875	1.3	1.3	38 000	40 500	3 900	4 150	7 100	9 500
	57.150	22.225	22.225	17.462	0.8	1.5	48 000	50 000	4 850	5 100	7 100	9 500

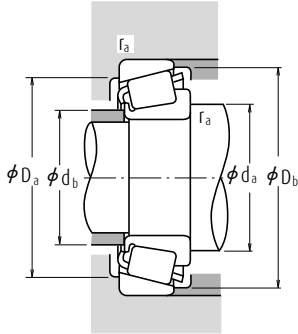

**Dynamic Equivalent Load**  $P = XF_r + YF_a$

$F_a/F_r \leq e$		$F_a/F_r > e$	
X	Y	X	Y
1	0	0.4	$Y_1$

**Static Equivalent Load**

$$P_0 = 0.5F_r + Y_0F_a$$

When  $F_r > 0.5F_r + Y_0F_a$ , use  $P_0 = F_r$

The values of  $e$ ,  $Y_1$  and  $Y_0$  are given in the table below.

Bearing Numbers		Abutment and Fillet Dimensions (mm)						Eff. Load Centers (mm)	Constant	Axial Load Factors		Mass (kg)	
CONE	CUP	$d_a$	$d_b$	$D_a$	$D_b$	Cone $r_a$ max.	Cup			$a$	$e$	$Y_1$	$Y_0$
*A 2047	A 2126	16.5	15.5	26	29	0.8	1.3	6.8	0.41	1.5	0.81	0.023	0.017
A 4050	A 4138	18.5	17	29	32	1.3	1.3	8.2	0.45	1.3	0.73	0.033	0.022
*A 4059	A 4138	19.5	19	29	32	0.8	1.3	8.2	0.45	1.3	0.73	0.029	0.022
L 21549	L 21511	21.5	19.5	29	32.5	1.3	1.3	7.7	0.32	1.9	1.0	0.031	0.018
A 6062	A 6157	22	20.5	34	37	1.3	1.3	10.3	0.53	1.1	0.63	0.044	0.031
03062	03162	21.5	20	34	37.5	1.3	2	9.1	0.31	1.9	1.1	0.061	0.035
11590	11520	24.5	22.5	34.5	39.5	1.5	1.5	13.0	0.70	0.85	0.47	0.061	0.040
17580	17520	23	21	36.5	39	1.5	1.5	10.6	0.33	1.8	1.0	0.075	0.048
05062	05175	23.5	21	38	42	1.5	1.5	11.2	0.36	1.7	0.93	0.081	0.039
09062	09195	22	21.5	42	44.5	0.8	1.3	10.7	0.27	2.3	1.2	0.139	0.065
*HM 81649	**HM 81610	27.5	23	37.5	43	1	2	14.9	0.55	1.1	0.60	0.115	0.082
A 6067	A 6157	22	21	34	37	0.8	1.3	10.3	0.53	1.1	0.63	0.042	0.031
A 5069	A 5144	23.5	21.5	30	33.5	1.5	1.5	8.9	0.49	1.2	0.68	0.030	0.020
† LM 11749	† LM 11710	23	21.5	34	37	1.3	1.3	8.7	0.29	2.1	1.2	0.055	0.028
05068	05185	23	22.5	40.5	42.5	0.8	1.3	10.1	0.36	1.7	0.93	0.082	0.047
A 6075	A 6157	24	23	34	37	1	1.3	10.3	0.53	1.1	0.63	0.037	0.031
† LM 11949	† LM 11910	25	23.5	39.5	41.5	1.3	1.3	9.5	0.30	2.0	1.1	0.081	0.044
05075	05185	25	23.5	40.5	42.5	1.3	1.3	10.1	0.36	1.7	0.93	0.077	0.047
09067	09195	25.5	24	42	44.5	1.3	1.3	10.7	0.27	2.3	1.2	0.115	0.065
09078	09195	25.5	24	42	44.5	1.2	1.3	10.7	0.27	2.3	1.2	0.124	0.065
09067	09196	25.5	24	41.5	44.5	1.3	1.5	13.8	0.27	2.3	1.2	0.115	0.085
09074	09194	26	24	39	44.5	1.5	3.5	13.8	0.27	2.3	1.2	0.124	0.082
21075	21212	31.5	26	43	50	1.5	2.3	16.3	0.59	1.0	0.56	0.156	0.097
05079	05185	26.5	24	40.5	42.5	1.5	1.3	10.1	0.36	1.7	0.93	0.073	0.047
07079	07204	27.5	27	45	48	1.5	1.3	12.1	0.40	1.5	0.82	0.105	0.061
09081	09196	27.5	25.5	41.5	44.5	1.5	1.5	13.8	0.27	2.3	1.2	0.115	0.085
12580	12520	28.5	26	42.5	45.5	1.5	1.5	12.9	0.32	1.9	1.0	0.114	0.067
† M 12649	† M 12610	27.5	25.5	44	46	1.3	1.3	10.9	0.28	2.2	1.2	0.115	0.059
*† LM 12749	† LM 12710	27.5	26	39.5	42.5	1.3	1.3	10.0	0.31	2.0	1.1	0.078	0.038
*† LM 12749	† LM 12711	27.5	26	40	42.5	1.3	1.3	10.0	0.31	2.0	1.1	0.078	0.043
07087	07196	28.5	27	44.5	47	1.3	1	10.6	0.40	1.5	0.82	0.097	0.035
† M 12648	† M 12610	28.5	26.5	44	46	1.3	1.3	10.9	0.28	2.2	1.2	0.111	0.059
1380	1328	29.5	27	45	48.5	1.5	1.5	11.3	0.29	2.1	1.1	0.137	0.067
1380	1329	29.5	27	46	49	1.5	1.5	11.3	0.29	2.1	1.1	0.137	0.082
1755	1729	29	27.5	49	51	1.3	1.3	12.2	0.31	2.0	1.1	0.152	0.102
1280	1220	29.5	29	49	52	0.8	1.5	15.1	0.35	1.7	0.95	0.183	0.106

- Notes**
- \* The maximum bore diameter is listed and its tolerance is negative (See Table 8.4.1 on Page A70).
  - \*\* The maximum outside diameter is listed and its tolerance is negative (See Table 8.4.2 on Pages A70 and A71).
  - † The tolerances for the bore diameter and overall bearing width differ from the standard (See Table 5 on Page B140).
  - \*† The tolerance for the bore diameter is 0 to -20 μm, and for overall bearing width is +356 to 0 μm.

# Single-Row Tapered Roller Bearings (Inch Design)

Bore Diameter 22.606 – 28.575 mm

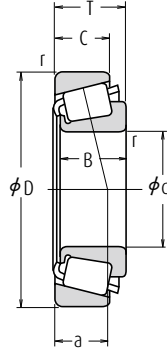

d	Boundary Dimensions (mm)					Cone		Basic Load Ratings (N)				Limiting Speeds (min <sup>-1</sup> )	
	D	T	B	C	r	Cup	C <sub>r</sub>	C <sub>0r</sub>	C <sub>r</sub>	C <sub>0r</sub>	Grease	Oil	
22.606	47.000	15.500	15.500	12.000	1.5	1.0	26 300	30 000	2 680	3 100	8 000	11 000	
23.812	50.292	14.224	14.732	10.668	1.5	1.3	27 600	32 000	2 820	3 250	7 100	10 000	
56.896	19.368	19.837	15.875	0.8	1.3	38 000	40 500	3 900	4 150	7 100	9 500		
24.000	55.000	25.000	25.000	21.000	2.0	2.0	49 500	55 000	5 050	5 650	7 100	9 500	
24.981	51.994	15.011	14.260	12.700	1.5	1.3	26 000	27 900	2 650	2 840	7 500	10 000	
52.001	15.011	14.260	12.700	1.5	2.0	26 000	27 900	2 650	2 840	7 500	10 000		
62.000	16.002	16.566	14.288	1.5	1.5	37 000	39 500	3 750	4 000	6 300	8 500		
25.000	50.005	13.495	14.260	9.525	1.5	1.0	26 000	27 900	2 650	2 840	7 500	10 000	
51.994	15.011	14.260	12.700	1.5	1.3	26 000	27 900	2 650	2 840	7 500	10 000		
25.400	50.005	13.495	14.260	9.525	3.3	1.0	26 000	27 900	2 650	2 840	7 500	10 000	
50.005	13.495	14.260	9.525	1.0	1.0	26 000	27 900	2 650	2 840	7 500	10 000		
50.292	14.224	14.732	10.668	1.3	1.3	27 600	32 000	2 820	3 250	7 100	10 000		
57.150	17.462	17.462	13.495	1.3	1.5	39 500	45 500	4 050	4 650	6 700	9 000		
57.150	19.431	19.431	14.732	1.5	1.5	42 500	49 000	4 300	5 000	6 700	9 000		
59.530	23.368	23.114	18.288	0.8	1.5	50 000	58 000	5 100	5 900	6 300	9 000		
62.000	19.050	20.638	14.288	0.8	1.3	46 000	53 000	4 700	5 400	6 000	8 000		
63.500	20.638	20.638	15.875	3.5	1.5	46 000	53 000	4 700	5 400	6 000	8 000		
64.292	21.433	21.433	16.670	1.5	1.5	51 000	64 500	5 200	6 600	5 600	8 000		
65.088	22.225	21.463	15.875	1.5	1.5	45 000	47 500	4 600	4 850	5 600	8 000		
68.262	22.225	22.225	17.462	0.8	1.5	55 000	64 000	5 600	6 550	5 600	7 500		
72.233	25.400	25.400	19.842	0.8	2.3	63 500	83 500	6 500	8 500	5 000	7 100		
72.626	24.608	24.257	17.462	2.3	1.5	60 000	58 000	6 100	5 900	5 600	7 500		
26.988	50.292	14.224	14.732	10.668	3.5	1.3	27 600	32 000	2 820	3 250	7 100	10 000	
57.150	19.845	19.355	15.875	3.3	1.5	40 000	44 500	4 100	4 500	6 700	9 000		
60.325	19.842	17.462	15.875	3.5	1.5	39 500	45 500	4 050	4 650	6 700	9 000		
62.000	19.050	20.638	14.288	0.8	1.3	46 000	53 000	4 700	5 400	6 000	8 000		
28.575	57.150	19.845	19.355	15.875	3.5	1.5	40 000	44 500	4 100	4 500	6 700	9 000	
59.131	15.875	16.764	11.811	spec.	1.3	34 500	41 500	3 550	4 200	6 300	8 500		
62.000	19.050	20.638	14.288	3.5	1.3	46 000	53 000	4 700	5 400	6 000	8 000		
62.000	19.050	20.638	14.288	0.8	1.3	46 000	53 000	4 700	5 400	6 000	8 000		
64.292	21.433	21.433	16.670	1.5	1.5	51 000	64 500	5 200	6 600	5 600	8 000		
68.262	22.225	22.225	17.462	0.8	1.5	55 000	64 000	5 600	6 550	5 600	7 500		
72.626	24.608	24.257	17.462	4.8	1.5	60 000	58 000	6 100	5 900	5 600	7 500		
72.626	24.608	24.257	17.462	1.5	1.5	60 000	58 000	6 100	5 900	5 600	7 500		
73.025	22.225	22.225	17.462	0.8	3.3	54 500	64 500	5 550	6 600	5 300	7 100		

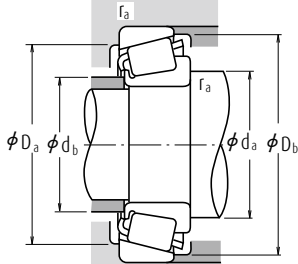

**Dynamic Equivalent Load**  $P = X F_r + Y F_a$

$F_a/F_r \leq e$		$F_a/F_r > e$	
X	Y	X	Y
1	0	0.4	$Y_1$

**Static Equivalent Load**

$$P_0 = 0.5 F_r + Y_0 F_a$$

When  $F_r > 0.5 F_r + Y_0 F_a$ , use  $P_0 = F_r$

The values of  $e$ ,  $Y_1$  and  $Y_0$  are given in the table below.

Bearing Numbers		Abutment and Fillet Dimensions (mm)						Eff. Load Centers (mm)	Constant	Axial Load Factors		Mass (kg)	
CONE	CUP	$d_a$	$d_b$	$D_a$	$D_b$	Cone $r_a$ max.	Cup			$e$	$Y_1$	$Y_0$	CONE
LM 72849	LM 72810	29	27	40.5	44.5	1.5	1	12.2	0.47	1.3	0.70	0.086	0.046
† L 44640	† L 44610	30.5	28.5	44.5	47	1.5	1.3	10.9	0.37	1.6	0.88	0.097	0.039
1779	1729	29.5	28.5	49	51	0.8	1.3	12.2	0.31	2.0	1.1	0.143	0.102
▲ JHM 33449	▲ JHM 33410	35	30	47	52	2	2	15.8	0.35	1.7	0.93	0.181	0.107
07098	07204	31	29	45	48	1.5	1.3	12.1	0.40	1.5	0.82	0.085	0.061
07098	07205	31	29	44.5	48	1.5	2	12.1	0.40	1.5	0.82	0.085	0.061
17098	17244	33	30.5	54	57	1.5	1.5	12.8	0.38	1.6	0.86	0.165	0.091
07097	07196	31	29	44.5	47	1.5	1	10.6	0.40	1.5	0.82	0.085	0.035
07097	07204	31	29	45	48	1.5	1.3	12.1	0.40	1.5	0.82	0.085	0.061
07100 SA	07196	35	29.5	44.5	47	3.3	1	10.6	0.40	1.5	0.82	0.082	0.035
07100	07196	30.5	29.5	44.5	47	1	1	10.6	0.40	1.5	0.82	0.084	0.035
† L 44643	† L 44610	31.5	29.5	44.5	47	1.3	1.3	10.9	0.37	1.6	0.88	0.090	0.039
15578	15520	32.5	30.5	51	53	1.3	1.5	12.4	0.35	1.7	0.95	0.151	0.070
M 84548	M 84510	36	33	48.5	54	1.5	1.5	16.1	0.55	1.1	0.60	0.156	0.089
M 84249	M 84210	36	32.5	49.5	56	0.8	1.5	18.3	0.55	1.1	0.60	0.194	0.13
15101	15245	32.5	31.5	55	58	0.8	1.3	13.3	0.35	1.7	0.94	0.222	0.081
15100	15250 X	38	31.5	55	59	3.5	1.5	14.9	0.35	1.7	0.94	0.22	0.113
M 86643	M 86610	38	36.5	54	61	1.5	1.5	17.7	0.55	1.1	0.60	0.246	0.128
23100	23256	39	34.5	53	61	1.5	1.5	20.0	0.73	0.82	0.45	0.214	0.142
02473	02420	34.5	33.5	59	63	0.8	1.5	16.9	0.42	1.4	0.79	0.28	0.152
HM 88630	HM 88610	39.5	39.5	60	69	0.8	2.3	20.7	0.55	1.1	0.60	0.398	0.188
41100	41286	41	36.5	61	68	2.3	1.5	20.7	0.60	1.0	0.55	0.32	0.177
† L 44649	† L 44610	37.5	31	44.5	47	3.5	1.3	10.9	0.37	1.6	0.88	0.081	0.039
1997 X	1922	37.5	31.5	51	53.5	3.3	1.5	13.9	0.33	1.8	1.0	0.152	0.077
15580	15523	38.5	32	51	54	3.5	1.5	14.7	0.35	1.7	0.95	0.141	0.123
15106	15245	33.5	33	55	58	0.8	1.3	13.3	0.35	1.7	0.94	0.211	0.081
1988	1922	39.5	33.5	51	53.5	3.5	1.5	13.9	0.33	1.8	1.0	0.141	0.077
† LM 67043	† LM 67010	40	33.5	52	56	3.5	1.3	12.6	0.41	1.5	0.80	0.147	0.062
15112	15245	40	34	55	58	3.5	1.3	13.3	0.35	1.7	0.94	0.199	0.081
15113	15245	34.5	34	55	58	0.8	1.3	13.3	0.35	1.7	0.94	0.20	0.081
M 86647	M 86610	40	38	54	61	1.5	1.5	17.7	0.55	1.1	0.60	0.223	0.128
02474	02420	36.5	36	59	63	0.8	1.5	16.9	0.42	1.4	0.79	0.257	0.152
41125	41286	48	36.5	61	68	4.8	1.5	20.7	0.60	1.0	0.55	0.292	0.177
41126	41286	41.5	36.5	61	68	1.5	1.5	20.7	0.60	1.0	0.55	0.295	0.177
02872	02820	37.5	37	62	68	0.8	3.3	18.3	0.45	1.3	0.73	0.321	0.16

**Notes** † The tolerances for the bore diameter and overall bearing width differ from the standard (See Table 5 on Page B140).

▲ The tolerances are listed in Tables 2, 3 and 4 on Pages B139 and B140.

# Single-Row Tapered Roller Bearings (Inch Design)

Bore Diameter 29.000 – 32.000 mm

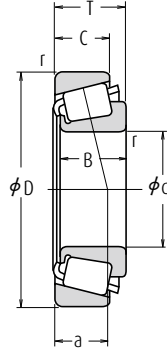

d	Boundary Dimensions (mm)					Cone		Basic Load Ratings (N) {kgf}				Limiting Speeds (min <sup>-1</sup> )	
	D	T	B	C		r min.	C <sub>r</sub>	C <sub>or</sub>	C <sub>r</sub>	C <sub>or</sub>	Grease	Oil	
<b>29.000</b>	50.292	14.224	14.732	10.668		3.5	1.3	26 800	34 000	2 730	3 500	7 100	9 500
<b>29.367</b>	66.421	23.812	25.433	19.050		3.5	1.3	65 000	73 000	6 600	7 450	6 000	8 000
<b>30.000</b>	62.000	16.002	16.566	14.288		1.5	1.5	37 000	39 500	3 750	4 000	6 300	8 500
	62.000	19.050	20.638	14.288		1.3	1.3	46 000	53 000	4 700	5 400	6 000	8 000
	63.500	20.638	20.638	15.875		1.3	1.3	46 000	53 000	4 700	5 400	6 000	8 000
	72.000	19.000	18.923	15.875		1.5	1.5	52 000	56 000	5 300	5 700	5 600	7 500
<b>30.112</b>	62.000	19.050	20.638	14.288		0.8	1.3	46 000	53 000	4 700	5 400	6 000	8 000
<b>30.162</b>	58.738	14.684	15.080	10.716		3.5	1.0	28 800	33 500	2 940	3 450	6 000	8 000
	64.292	21.433	21.433	16.670		1.5	1.5	51 000	64 500	5 200	6 600	5 600	8 000
	68.262	22.225	22.225	17.462		2.3	1.5	55 500	70 500	5 650	7 200	5 300	7 500
	69.850	23.812	25.357	19.050		2.3	1.3	71 000	84 000	7 200	8 550	5 600	7 500
	69.850	23.812	25.357	19.050		0.8	1.3	71 000	84 000	7 200	8 550	5 600	7 500
	76.200	24.608	24.074	16.670		1.5	C3.3	67 500	69 500	6 850	7 100	5 000	6 700
<b>30.213</b>	62.000	19.050	20.638	14.288		3.5	1.3	46 000	53 000	4 700	5 400	6 000	8 000
	62.000	19.050	20.638	14.288		0.8	1.3	46 000	53 000	4 700	5 400	6 000	8 000
	62.000	19.050	20.638	14.288		1.5	1.3	46 000	53 000	4 700	5 400	6 000	8 000
<b>30.955</b>	64.292	21.433	21.433	16.670		1.5	1.5	51 000	64 500	5 200	6 600	5 600	8 000
<b>31.750</b>	58.738	14.684	15.080	10.716		1.0	1.0	28 800	33 500	2 940	3 450	6 000	8 000
	59.131	15.875	16.764	11.811		spec.	1.3	34 500	41 500	3 550	4 200	6 300	8 500
	62.000	18.161	19.050	14.288		spec.	1.3	46 000	53 000	4 700	5 400	6 000	8 000
	62.000	19.050	20.638	14.288		0.8	1.3	46 000	53 000	4 700	5 400	6 000	8 000
	62.000	19.050	20.638	14.288		3.5	1.3	46 000	53 000	4 700	5 400	6 000	8 000
	63.500	20.638	20.638	15.875		0.8	1.3	46 000	53 000	4 700	5 400	6 000	8 000
	68.262	22.225	22.225	17.462		3.5	1.5	55 000	64 000	5 600	6 550	5 600	7 500
	68.262	22.225	22.225	17.462		1.5	1.5	55 500	70 500	5 650	7 200	5 300	7 500
	69.012	19.845	19.583	15.875		3.5	1.3	47 000	56 000	4 800	5 700	5 600	7 500
	69.012	26.982	26.721	15.875		4.3	3.3	47 000	56 000	4 800	5 700	5 600	7 500
	69.850	23.812	25.357	19.050		0.8	1.3	71 000	84 000	7 200	8 550	5 600	7 500
	69.850	23.812	25.357	19.050		3.5	1.3	71 000	84 000	7 200	8 550	5 600	7 500
	72.626	30.162	29.997	23.812		0.8	3.3	79 500	90 000	8 100	9 200	5 300	7 500
	73.025	29.370	27.783	23.020		1.3	3.3	74 000	100 000	7 550	10 200	5 000	7 100
	80.000	21.000	22.403	17.826		0.8	1.3	68 500	75 500	6 950	7 700	4 500	6 300
<b>32.000</b>	72.233	25.400	25.400	19.842		3.3	2.3	63 500	83 500	6 500	8 500	5 000	7 100

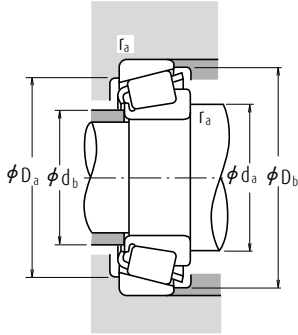

**Dynamic Equivalent Load**  $P = X F_r + Y F_a$

$F_a/F_r \leq e$		$F_a/F_r > e$	
X	Y	X	Y
1	0	0.4	$Y_1$

**Static Equivalent Load**

$$P_0 = 0.5 F_r + Y_0 F_a$$

When  $F_r > 0.5 F_r + Y_0 F_a$ , use  $P_0 = F_r$

The values of  $e$ ,  $Y_1$  and  $Y_0$  are given in the table below.

Bearing Numbers		Abutment and Fillet Dimensions (mm)						Eff. Load Centers (mm)	Constant	Axial Load Factors		Mass (kg)	
CONE	CUP	$d_a$	$d_b$	$D_a$	$D_b$	Cone Cup $r_a$ max.	a			e	$Y_1$	$Y_0$	CONE
† L 45449	† L 45410	39.5	33	44.5	48	3.5	1.3	10.8	0.37	1.6	0.89	0.079	0.036
2690	2631	41	35	58	60	3.5	1.3	14.3	0.25	2.4	1.3	0.242	0.165
* 17118	17244	37	34.5	54	57	1.5	1.5	12.8	0.38	1.6	0.86	0.136	0.091
* 15117	15245	36.5	35	55	58	1.3	1.3	13.3	0.35	1.7	0.94	0.189	0.081
* 15117	15250	36.5	35	56	59	1.3	1.3	14.9	0.35	1.7	0.94	0.189	0.113
* 26118	26283	38	36	62	65	1.5	1.5	14.8	0.36	1.7	0.92	0.225	0.163
15116	15245	36	35.5	55	58	0.8	1.3	13.3	0.35	1.7	0.94	0.189	0.081
08118	08231	41.5	35	52	55	3.5	1	13.3	0.47	1.3	0.70	0.12	0.057
M 86649	M 86610	41	38	54	61	1.5	1.5	17.7	0.55	1.1	0.60	0.211	0.128
M 88043	M 88010	43.5	39.5	58	65	2.3	1.5	19.1	0.55	1.1	0.60	0.263	0.146
2558	2523	40	36.5	61	64	2.3	1.3	14.5	0.27	2.2	1.2	0.297	0.169
2559	2523	37	36.5	61	64	0.8	1.3	14.5	0.27	2.2	1.2	0.298	0.169
43118	43300	45	42	64	73	1.5	3.3	22.9	0.67	0.90	0.49	0.383	0.146
15118	15245	41.5	35.5	55	58	3.5	1.3	13.3	0.35	1.7	0.94	0.186	0.081
15120	15245	36	35.5	55	58	0.8	1.3	13.3	0.35	1.7	0.94	0.188	0.081
15119	15245	37.5	35.5	55	58	1.5	1.3	13.3	0.35	1.7	0.94	0.188	0.081
M 86648 A	M 86610	42	38	54	61	1.5	1.5	17.7	0.55	1.1	0.60	0.205	0.128
08125	08231	37.5	36	52	55	1	1	13.3	0.47	1.3	0.70	0.113	0.057
† LM 67048	† LM 67010	42.5	36	52	56	3.5	1.3	12.6	0.41	1.5	0.80	0.127	0.062
15123	15245	42.5	36.5	55	58	3.5	1.3	13.3	0.35	1.7	0.94	0.165	0.081
15126	15245	37	36.5	55	58	0.8	1.3	13.3	0.35	1.7	0.94	0.176	0.081
15125	15245	42.5	36.5	55	58	3.5	1.3	13.3	0.35	1.7	0.94	0.174	0.081
15126	15250	37	36.5	56	59	0.8	1.3	14.9	0.35	1.7	0.94	0.176	0.113
02475	02420	44.5	38.5	59	63	3.5	1.5	16.9	0.42	1.4	0.79	0.229	0.152
M 88046	M 88010	43	40.5	58	65	1.5	1.5	19.1	0.55	1.1	0.60	0.25	0.146
14125 A	14276	44	37.5	60	63	3.5	1.3	15.3	0.38	1.6	0.86	0.219	0.135
14123 A	14274	41.5	37.5	59	63	4.3	3.3	15.1	0.38	1.6	0.87	0.289	0.132
2580	2523	38.5	37.5	61	64	0.8	1.3	14.5	0.27	2.2	1.2	0.282	0.169
2582	2523	44	37.5	61	64	3.5	1.3	14.5	0.27	2.2	1.2	0.28	0.169
3188	3120	39.5	39.5	61	67	0.8	3.3	19.6	0.33	1.8	0.99	0.368	0.225
HM 88542	HM 88510	45.5	42.5	59	70	1.3	3.3	23.5	0.55	1.1	0.60	0.379	0.242
346	332	40	39.5	73	75	0.8	1.3	14.6	0.27	2.2	1.2	0.419	0.146
*HM 88638	HM 88610	48.5	42.5	60	69	3.3	2.3	20.7	0.55	1.1	0.60	0.337	0.188

**Notes** \* The maximum bore diameter is listed and its tolerance is negative (See Table 8.4.1 on Page A70).

† The tolerances for the bore diameter and overall bearing width differ from the standard (See Table 5 on Page B140).



# Single-Row Tapered Roller Bearings (Inch Design)

Bore Diameter 33.338 – 35.000 mm

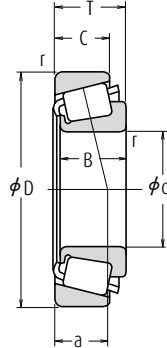

d	Boundary Dimensions (mm)					Cone		Basic Load Ratings (N)				Limiting Speeds (min <sup>-1</sup> )	
	D	T	B	C	r	Cup	C <sub>r</sub>	C <sub>0r</sub>	C <sub>r</sub>	C <sub>0r</sub>	Grease	Oil	
33.338	66.675	20.638	20.638	15.875	3.5	1.5	46 000	53 500	4 650	5 450	5 600	7 500	
	68.262	22.225	22.225	17.462	0.8	1.5	55 500	70 500	5 650	7 200	5 300	7 500	
	69.012	19.845	19.583	15.875	3.5	3.3	47 000	56 000	4 800	5 700	5 600	7 500	
	69.012	19.845	19.583	15.875	0.8	1.3	47 000	56 000	4 800	5 700	5 600	7 500	
	69.850	23.812	25.357	19.050	3.5	1.3	71 000	84 000	7 200	8 550	5 600	7 500	
	72.000	19.000	18.923	15.875	3.5	1.5	52 000	56 000	5 300	5 700	5 600	7 500	
	72.626	30.162	29.997	23.812	0.8	3.3	79 500	90 000	8 100	9 200	5 300	7 500	
	73.025	29.370	27.783	23.020	0.8	3.3	74 000	100 000	7 550	10 200	5 000	7 100	
	76.200	29.370	28.575	23.020	3.8	0.8	78 500	106 000	8 000	10 800	4 800	6 700	
	76.200	29.370	28.575	23.020	0.8	3.3	78 500	106 000	8 000	10 800	4 800	6 700	
34.925	79.375	25.400	24.074	17.462	3.5	1.5	67 500	69 500	6 850	7 100	5 000	6 700	
	65.088	18.034	18.288	13.970	spec.	1.3	47 500	57 500	4 850	5 900	5 600	7 500	
	65.088	20.320	18.288	16.256	spec.	1.3	47 500	57 500	4 850	5 900	5 600	7 500	
	66.675	20.638	20.638	16.670	3.5	2.3	53 000	62 500	5 400	6 400	5 600	7 500	
	69.012	19.845	19.583	15.875	3.5	1.3	47 000	56 000	4 800	5 700	5 600	7 500	
	69.012	19.845	19.583	15.875	1.5	1.3	47 000	56 000	4 800	5 700	5 600	7 500	
	72.233	25.400	25.400	19.842	2.3	2.3	63 500	83 500	6 500	8 500	5 000	7 100	
	73.025	22.225	22.225	17.462	0.8	3.3	54 500	64 500	5 550	6 600	5 300	7 100	
	73.025	22.225	23.812	17.462	3.5	3.3	63 500	77 000	6 500	7 850	5 300	7 100	
	73.025	23.812	24.608	19.050	1.5	0.8	71 000	86 000	7 250	8 750	5 300	7 100	
34.976	73.025	23.812	24.608	19.050	3.5	2.3	71 000	86 000	7 250	8 750	5 300	7 100	
	76.200	29.370	28.575	23.020	0.8	0.8	78 500	106 000	8 000	10 800	4 800	6 700	
	76.200	29.370	28.575	23.020	3.5	0.8	78 500	106 000	8 000	10 800	4 800	6 700	
	76.200	29.370	28.575	23.020	3.5	3.3	78 500	106 000	8 000	10 800	4 800	6 700	
	76.200	29.370	28.575	23.812	1.5	3.3	80 500	96 500	8 200	9 850	5 000	6 700	
	79.375	29.370	29.771	23.812	3.5	3.3	88 000	106 000	8 950	10 800	4 800	6 700	
	68.262	15.875	16.520	11.908	1.5	1.5	45 000	53 500	4 600	5 450	5 300	7 100	
	72.085	22.385	19.583	18.415	1.3	2.3	47 000	56 000	4 800	5 700	5 600	7 500	
	80.000	21.006	20.940	15.875	1.5	1.5	56 500	64 500	5 750	6 600	5 000	6 700	
	35.000	59.131	15.875	16.764	11.938	spec.	1.3	35 000	47 000	3 550	4 750	6 000	8 000
59.975		15.875	16.764	11.938	spec.	1.3	35 000	47 000	3 550	4 750	6 000	8 000	
62.000		16.700	17.000	13.600	spec.	1.0	38 000	50 000	3 900	5 100	5 600	8 000	
62.000		16.700	17.000	13.600	spec.	1.5	38 000	50 000	3 900	5 100	5 600	8 000	
65.987		20.638	20.638	16.670	3.5	2.3	53 000	62 500	5 400	6 400	5 600	7 500	
73.025		26.988	26.975	22.225	3.5	0.8	75 500	88 500	7 650	9 050	5 300	7 500	

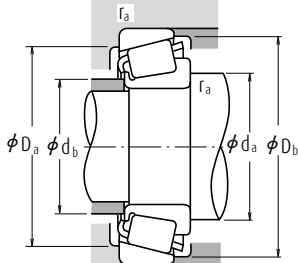

**Dynamic Equivalent Load**  $P = XF_r + YF_a$

$F_a/F_r \leq e$		$F_a/F_r > e$	
X	Y	X	Y
1	0	0.4	$Y_1$

**Static Equivalent Load**

$$P_0 = 0.5F_r + Y_0F_a$$

When  $F_r > 0.5F_r + Y_0F_a$ , use  $P_0 = F_r$

The values of  $e$ ,  $Y_1$  and  $Y_0$  are given in the table below.

Bearing Numbers		Abutment and Fillet Dimensions (mm)						Eff. Load Centers (mm)	Constant	Axial Load Factors		Mass (kg)	
CONE	CUP	$d_a$	$d_b$	$D_a$	$D_b$	Cone $r_a$ max.	Cup			$e$	$Y_1$	$Y_0$	CONE
1680	1620	44.5	38.5	58	61	3.5	1.5	15.2	0.37	1.6	0.89	0.196	0.121
M 88048	M 88010	42.5	41	58	65	0.8	1.5	19.0	0.55	1.1	0.60	0.236	0.146
14130	14274	45	38.5	59	63	3.5	3.3	15.3	0.38	1.6	0.86	0.207	0.132
14131	14276	39.5	38.5	60	63	0.8	1.3	15.3	0.38	1.6	0.86	0.209	0.135
2585	2523	45	39	61	64	3.5	1.3	14.5	0.27	2.2	1.2	0.263	0.169
26131	26283	44.5	38.5	62	65	3.5	1.5	14.7	0.36	1.7	0.92	0.20	0.163
3197	3120	41.5	40.5	61	67	0.8	3.3	19.6	0.33	1.8	0.99	0.348	0.225
HM 88547	HM 88510	45.5	42.5	59	70	0.8	3.3	23.5	0.55	1.1	0.60	0.362	0.242
HM 89444	HM 89411	53	44.5	65	73	3.8	0.8	23.6	0.55	1.1	0.60	0.419	0.261
HM 89443	HM 89410	46.5	44.5	62	73	0.8	3.3	23.6	0.55	1.1	0.60	0.421	0.257
43131	43312	51	42	67	74	3.5	1.5	23.7	0.67	0.90	0.49	0.348	0.22
† LM 48548	† LM 48510	46	40	58	61	3.5	1.3	14.1	0.38	1.6	0.88	0.172	0.087
† LM 48548	† LM 48511	46	40	58	61	3.5	1.3	16.4	0.38	1.6	0.88	0.172	0.108
M 38549	M 38510	46.5	40	58	62	3.5	2.3	15.2	0.35	1.7	0.94	0.194	0.112
14138 A	14276	46	40	60	63	3.5	1.3	15.3	0.38	1.6	0.86	0.194	0.135
14137 A	14276	42	40	60	63	1.5	1.3	15.1	0.38	1.6	0.86	0.196	0.135
HM 88649	HM 88610	48.5	42.5	60	69	2.3	2.3	20.7	0.55	1.1	0.60	0.307	0.188
02878	02820	42.5	42	62	68	0.8	3.3	18.3	0.45	1.3	0.73	0.266	0.16
2877	2820	47	41.5	63	68	3.5	3.3	16.1	0.37	1.6	0.90	0.291	0.15
25877	25821	43	40.5	65	68	1.5	0.8	15.7	0.29	2.1	1.1	0.306	0.167
25878	25820	47	40.5	64	68	3.5	2.3	15.7	0.29	2.1	1.1	0.304	0.165
HM 89446 A	HM 89411	47.5	44.5	65	73	0.8	0.8	23.6	0.55	1.1	0.60	0.403	0.261
HM 89446	HM 89411	53	44.5	65	73	3.5	0.8	23.6	0.55	1.1	0.60	0.40	0.261
HM 89446	HM 89410	53	44.5	62	73	3.5	3.3	23.6	0.55	1.1	0.60	0.40	0.257
31594	31520	46	43.5	64	72	1.5	3.3	21.6	0.40	1.5	0.82	0.404	0.235
3478	3420	50	43.5	67	74	3.5	3.3	20.0	0.37	1.6	0.90	0.448	0.259
19138	19268	42.5	40.5	61	65	1.5	1.5	14.5	0.44	1.4	0.74	0.196	0.073
14139	14283	41.5	40	60	65	1.3	2.3	17.7	0.38	1.6	0.87	0.198	0.21
28138	28315	43.5	41	69	73	1.5	1.5	16.0	0.40	1.5	0.82	0.308	0.199
*† L 68149	† L 68110	45.5	39	52	56	3.5	1.3	13.2	0.42	1.4	0.79	0.117	0.056
*† L 68149	† L 68111	45.5	39	53	56	3.5	1.3	13.2	0.42	1.4	0.79	0.117	0.064
* LM 78349	** LM 78310	46	40	55	59	3.5	1	14.4	0.44	1.4	0.74	0.137	0.074
* LM 78349	** LM 78310 A	46	40	54	59	3.5	1.5	14.4	0.44	1.4	0.74	0.138	0.073
M 38547	M 38511	46	39.5	59	61	3.5	2.3	15.2	0.35	1.7	0.94	0.193	0.103
23691	23621	49	42	63	68	3.5	0.8	18.1	0.37	1.6	0.89	0.309	0.212

**Notes**

- \* The maximum bore diameter is listed and its tolerance is negative (See Table 8.4.1 on Page A70).
- \*\* The maximum outside diameter is listed and its tolerance is negative (See Table 8.4.2 on Pages A70 and A71).
- † The tolerances for the bore diameter and overall bearing width differ from the standard (See Table 5 on Page B140).
- \*† The tolerance for the bore diameter is 0 to -20 μm, and for overall bearing width is +356 to 0 μm.

# Single-Row Tapered Roller Bearings (Inch Design)

Bore Diameter 35.717 – 41.275 mm

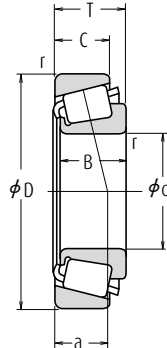

Boundary Dimensions (mm)							Basic Load Ratings (N) {kgf}				Limiting Speeds (min <sup>-1</sup> )	
d	D	T	B	C	Cone Cup		C <sub>r</sub>	C <sub>0r</sub>	C <sub>r</sub>	C <sub>0r</sub>	Grease	Oil
					r min.	r min.						
35.717	72.233	25.400	25.400	19.842	3.5	2.3	63 500	83 500	6 500	8 500	5 000	7 100
36.487	73.025	23.812	24.608	19.050	1.5	0.8	71 000	86 000	7 250	8 750	5 300	7 100
36.512	76.200	29.370	28.575	23.020	3.5	3.3	78 500	106 000	8 000	10 800	4 800	6 700
	79.375	29.370	29.771	23.812	0.8	3.3	88 000	106 000	8 950	10 800	4 800	6 700
	88.501	25.400	23.698	17.462	2.3	1.5	73 000	81 000	7 450	8 250	4 000	5 600
	93.662	31.750	31.750	26.195	1.5	3.3	110 000	142 000	11 200	14 400	4 000	5 600
38.000	63.000	17.000	17.000	13.500	spec.	1.3	38 500	52 000	3 900	5 300	5 600	7 500
38.100	63.500	12.700	11.908	9.525	1.5	0.8	24 100	30 500	2 460	3 100	5 300	7 100
	65.088	18.034	18.288	13.970	2.3	1.3	42 500	55 000	4 300	5 650	5 300	7 500
	65.088	18.034	18.288	13.970	spec.	1.3	42 500	55 000	4 300	5 650	5 300	7 500
	65.088	19.812	18.288	15.748	2.3	1.3	42 500	55 000	4 300	5 650	5 300	7 500
	68.262	15.875	16.520	11.908	1.5	1.5	45 000	53 500	4 600	5 450	5 300	7 100
	69.012	19.050	19.050	15.083	2.0	2.3	49 000	61 000	4 950	6 250	5 300	7 100
	69.012	19.050	19.050	15.083	3.5	0.8	49 000	61 000	4 950	6 250	5 300	7 100
	72.238	20.638	20.638	15.875	3.5	1.3	48 500	59 500	4 950	6 050	5 300	7 100
	73.025	23.812	25.654	19.050	3.5	0.8	73 500	91 000	7 500	9 300	5 000	6 700
	76.200	23.812	25.654	19.050	3.5	3.3	73 500	91 000	7 500	9 300	5 000	6 700
	76.200	23.812	25.654	19.050	3.5	0.8	73 500	91 000	7 500	9 300	5 000	6 700
	79.375	29.370	29.771	23.812	3.5	3.3	88 000	106 000	8 950	10 800	4 800	6 700
	80.035	24.608	23.698	18.512	0.8	1.5	69 000	84 500	7 000	8 600	4 500	6 300
	82.550	29.370	28.575	23.020	0.8	3.3	87 000	117 000	8 850	11 900	4 500	6 000
	88.501	25.400	23.698	17.462	2.3	1.5	73 000	81 000	7 450	8 250	4 000	5 600
	88.501	26.988	29.083	22.225	3.5	1.5	96 500	109 000	9 800	11 100	4 500	6 000
	95.250	30.958	28.301	20.638	1.5	0.8	87 500	97 000	8 950	9 850	3 600	5 300
39.688	73.025	25.654	22.098	21.336	0.8	2.3	62 500	80 000	6 400	8 150	5 000	6 700
	76.200	23.812	25.654	19.050	3.5	3.3	73 500	91 000	7 500	9 300	5 000	6 700
	80.167	29.370	30.391	23.812	0.8	3.3	92 500	108 000	9 450	11 000	4 800	6 300
40.000	80.000	21.000	22.403	17.826	3.5	1.3	68 500	75 500	6 950	7 700	4 500	6 300
	80.000	21.000	22.403	17.826	0.8	1.3	68 500	75 500	6 950	7 700	4 500	6 300
	88.501	25.400	23.698	17.462	2.3	1.5	73 000	81 000	7 450	8 250	4 000	5 600
41.000	68.000	17.500	18.000	13.500	spec.	1.5	43 500	58 000	4 450	5 950	5 300	7 100
41.275	73.025	16.667	17.462	12.700	3.5	1.5	44 500	54 000	4 550	5 500	4 800	6 700
	73.431	19.558	19.812	14.732	3.5	0.8	54 500	67 000	5 550	6 850	4 800	6 700
	73.431	21.430	19.812	16.604	3.5	0.8	54 500	67 000	5 550	6 850	4 800	6 700

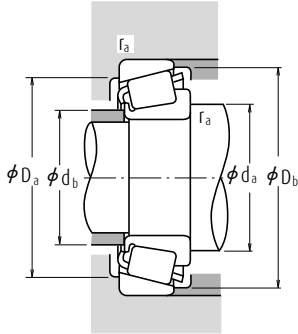

**Dynamic Equivalent Load**  $P = X F_r + Y F_a$

$F_a/F_r \leq e$		$F_a/F_r > e$	
X	Y	X	Y
1	0	0.4	$Y_1$

**Static Equivalent Load**

$$P_0 = 0.5 F_r + Y_0 F_a$$

When  $F_r > 0.5 F_r + Y_0 F_a$ , use  $P_0 = F_r$

The values of  $e$ ,  $Y_1$  and  $Y_0$  are given in the table below.

Bearing Numbers		Abutment and Fillet Dimensions (mm)						Eff. Load Centers (mm)	Constant	Axial Load Factors		Mass (kg)	
CONE	CUP	$d_a$	$d_b$	$D_a$	$D_b$	Cone $r_a$ max.	Cup			$e$	$Y_1$	$Y_0$	CONE
HM 88648	HM 88610	52	43	60	69	3.5	2.3	20.7	0.55	1.1	0.60	0.298	0.188
25880	25821	44	42	65	68	1.5	0.8	15.7	0.29	2.1	1.1	0.291	0.167
HM 89449	HM 89410	54	44.5	62	73	3.5	3.3	23.6	0.55	1.1	0.60	0.38	0.257
3479	3420	45.5	44.5	67	74	0.8	3.3	20.0	0.37	1.6	0.90	0.429	0.259
44143	44348	54	50	75	84	2.3	1.5	27.9	0.78	0.77	0.42	0.502	0.245
46143	46368	48.5	46.5	79	87	1.5	3.3	24.0	0.40	1.5	0.82	0.765	0.405
▲ JL 69349	▲ JL 69310	49	42.5	56	60	3.5	1.3	14.6	0.42	1.4	0.79	0.132	0.071
13889	13830	45	42.5	59	60	1.5	0.8	11.9	0.35	1.7	0.95	0.109	0.046
LM 29749	LM 29710	46	42.5	59	62	2.3	1.3	13.7	0.33	1.8	0.99	0.16	0.079
LM 29748	LM 29710	49	42.5	59	62	3.5	1.3	13.7	0.33	1.8	0.99	0.158	0.079
LM 29749	LM 29711	46	42.5	58	62	2.3	1.3	15.5	0.33	1.8	0.99	0.16	0.094
19150	19268	45	43	61	65	1.5	1.5	14.5	0.44	1.4	0.74	0.173	0.073
13687	13621	46.5	43	61	65	2	2.3	15.8	0.40	1.5	0.82	0.193	0.104
13685	13620	49.5	43	62	65	3.5	0.8	15.8	0.40	1.5	0.82	0.191	0.105
16150	16284	49.5	43	63	67	3.5	1.3	16.0	0.40	1.5	0.82	0.212	0.146
2788	2735 X	50	43.5	66	69	3.5	0.8	15.9	0.30	2.0	1.1	0.312	0.135
2788	2720	50	43.5	66	70	3.5	3.3	15.9	0.30	2.0	1.1	0.312	0.187
2788	2729	50	43.5	68	70	3.5	0.8	15.9	0.30	2.0	1.1	0.312	0.191
3490	3420	52	45.5	67	74	3.5	3.3	20.0	0.37	1.6	0.90	0.404	0.259
27880	27820	48	47	68	75	0.8	1.5	21.5	0.56	1.1	0.59	0.362	0.209
HM 801346	HM 801310	51	49	68	78	0.8	3.3	24.2	0.55	1.1	0.60	0.483	0.282
44150	44348	55	51	75	84	2.3	1.5	27.9	0.78	0.77	0.42	0.484	0.245
418	414	51	44.5	77	80	3.5	1.5	17.1	0.26	2.3	1.3	0.50	0.329
53150	53375	55	53	81	89	1.5	0.8	30.7	0.74	0.81	0.45	0.665	0.365
M 201047	M 201011	45.5	48	64	69	0.8	2.3	19.7	0.33	1.8	0.99	0.266	0.169
2789	2720	52	45	66	70	3.5	3.3	15.9	0.30	2.0	1.1	0.292	0.187
3386	3320	46.5	45.5	70	75	0.8	3.3	18.4	0.27	2.2	1.2	0.442	0.217
344	332	52	45.5	73	75	3.5	1.3	14.5	0.27	2.2	1.2	0.338	0.146
344 A	332	46	45.5	73	75	0.8	1.3	14.5	0.27	2.2	1.2	0.339	0.146
44157	44348	56	51	75	84	2.3	1.5	27.9	0.78	0.77	0.42	0.463	0.245
* LM 300849	** LM 300811	52	45	61	65	3.5	1.5	13.9	0.35	1.7	0.95	0.16	0.082
18590	18520	53	46	66	69	3.5	1.5	14.0	0.35	1.7	0.94	0.199	0.086
LM 501349	LM 501310	53	46.5	67	70	3.5	0.8	16.3	0.40	1.5	0.83	0.226	0.108
LM 501349	LM 501314	53	46.5	66	70	3.5	0.8	18.2	0.40	1.5	0.83	0.226	0.129

- Notes**
- \* The maximum bore diameter is listed and its tolerance is negative (See Table 8.4.1 on Page A70).
  - \*\* The maximum outside diameter is listed and its tolerance is negative (See Table 8.4.2 on Pages A70 and A71).
  - ▲ The tolerances are listed in Tables 2, 3 and 4 on Pages B139 and B140.

# Single-Row Tapered Roller Bearings (Inch Design)

Bore Diameter 41.275 – 44.450 mm

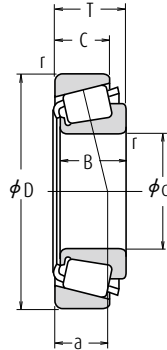

Boundary Dimensions (mm)							Basic Load Ratings (N) {kgf}				Limiting Speeds (min <sup>-1</sup> )	
d	D	T	B	C	Cone	Cup	C <sub>r</sub>	C <sub>or</sub>	C <sub>r</sub>	C <sub>or</sub>	Grease	Oil
					r min.	r min.						
41.275	76.200	18.009	17.384	14.288	1.5	1.5	42 500	51 000	4 350	5 200	4 500	6 300
	76.200	22.225	23.020	17.462	3.5	0.8	66 000	82 000	6 700	8 400	4 800	6 700
	76.200	25.400	23.020	20.638	3.5	2.3	66 000	82 000	6 700	8 400	4 800	6 700
	79.375	23.812	25.400	19.050	3.5	0.8	77 000	98 500	7 850	10 000	4 800	6 300
	80.000	21.000	22.403	17.826	0.8	1.3	68 500	75 500	6 950	7 700	4 500	6 300
	80.000	21.000	22.403	17.826	3.5	1.3	68 500	75 500	6 950	7 700	4 500	6 300
	80.167	25.400	25.400	20.638	3.5	3.3	77 000	98 500	7 850	10 000	4 800	6 300
	82.550	26.543	25.654	20.193	3.5	3.3	78 500	102 000	8 000	10 400	4 300	6 000
	85.725	30.162	30.162	23.812	3.5	3.3	91 000	115 000	9 300	11 700	4 300	6 000
	87.312	30.162	30.886	23.812	0.8	3.3	96 000	120 000	9 800	12 200	4 300	6 000
	88.501	25.400	23.698	17.462	2.3	1.5	73 000	81 000	7 450	8 250	4 000	5 600
	88.900	30.162	29.370	23.020	3.5	3.3	96 500	129 000	9 800	13 200	4 000	5 600
	88.900	30.162	29.370	23.020	0.8	3.3	96 500	129 000	9 800	13 200	4 000	5 600
	90.488	39.688	40.386	33.338	3.5	3.3	139 000	180 000	14 200	18 400	4 300	5 600
	93.662	31.750	31.750	26.195	0.8	3.3	110 000	142 000	11 200	14 400	4 000	5 600
95.250	30.162	29.370	23.020	3.5	3.3	106 000	143 000	10 800	14 500	3 800	5 300	
98.425	30.958	28.301	20.638	1.5	0.8	87 500	97 000	8 950	9 850	3 600	5 300	
42.862	76.992	17.462	17.145	11.908	1.5	1.5	44 000	54 000	4 450	5 500	4 500	6 000
	82.550	19.842	19.837	15.080	2.3	1.5	58 500	69 000	5 950	7 050	4 500	6 300
	82.931	23.812	25.400	19.050	2.3	0.8	76 500	99 000	7 800	10 100	4 500	6 000
	82.931	26.988	25.400	22.225	2.3	2.3	76 500	99 000	7 800	10 100	4 500	6 000
42.875	76.200	25.400	25.400	20.638	3.5	1.5	77 000	98 500	7 850	10 000	4 800	6 300
	80.000	21.000	22.403	17.826	3.5	1.3	68 500	75 500	6 950	7 700	4 500	6 300
	82.931	26.988	25.400	22.225	3.5	2.3	76 500	99 000	7 800	10 100	4 500	6 000
	83.058	23.812	25.400	19.050	3.5	3.3	76 500	99 000	7 800	10 100	4 500	6 000
43.000	74.988	19.368	19.837	14.288	1.5	1.3	52 500	68 000	5 350	6 900	4 800	6 300
	80.962	19.050	17.462	14.288	0.3	1.5	45 000	57 000	4 600	5 800	4 300	6 000
44.450	82.931	23.812	25.400	19.050	3.5	0.8	76 500	99 000	7 800	10 100	4 500	6 000
	83.058	23.812	25.400	19.050	3.5	3.3	76 500	99 000	7 800	10 100	4 500	6 000
	87.312	30.162	30.886	23.812	3.5	3.3	96 000	120 000	9 800	12 200	4 300	6 000
	88.900	30.162	29.370	23.020	3.5	3.3	96 500	129 000	9 800	13 200	4 000	5 600
	93.264	30.162	30.302	23.812	3.5	3.2	103 000	136 000	10 500	13 900	3 800	5 300
	93.662	31.750	31.750	25.400	0.8	3.3	120 000	147 000	12 200	15 000	4 000	5 600
	93.662	31.750	31.750	25.400	3.5	3.3	120 000	147 000	12 200	15 000	4 000	5 600
	93.662	31.750	31.750	26.195	3.5	3.3	110 000	142 000	11 200	14 400	4 000	5 600
	95.250	27.783	29.901	22.225	3.5	2.3	106 000	126 000	10 800	12 900	4 300	5 600

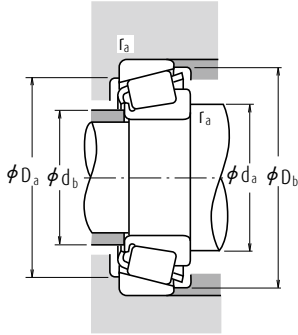

**Dynamic Equivalent Load**  $P = X F_r + Y F_a$

$F_a/F_r \leq e$		$F_a/F_r > e$	
X	Y	X	Y
1	0	0.4	$Y_1$

**Static Equivalent Load**

$P_0 = 0.5 F_r + Y_0 F_a$   
 When  $F_r > 0.5 F_r + Y_0 F_a$ , use  $P_0 = F_r$

The values of  $e$ ,  $Y_1$  and  $Y_0$  are given in the table below.

Bearing Numbers		Abutment and Fillet Dimensions (mm)					Cone	Cup	Eff. Load Centers (mm)	Constant	Axial Load Factors		Mass (kg)	
CONE	CUP	$d_a$	$d_b$	$D_a$	$D_b$	$r_a$ max.					a	e	$Y_1$	$Y_0$
11162	11300	49	46.5	67	71	1.5	1.5	17.4	0.49	1.2	0.68	0.212	0.129	
24780	24720	53	47.5	68	72	3.5	0.8	17.0	0.39	1.5	0.84	0.279	0.15	
24780	24721	54	47	66	72	3.5	2.3	20.2	0.39	1.5	0.84	0.279	0.189	
26882	26822	54	47	71	74	3.5	0.8	16.4	0.32	1.9	1.0	0.349	0.186	
336	332	47	46	73	75	0.8	1.3	14.5	0.27	2.2	1.2	0.325	0.146	
342	332	53	46	73	75	3.5	1.3	14.5	0.27	2.2	1.2	0.323	0.146	
26882	26820	54	47	69	74	3.5	3.3	18.0	0.32	1.9	1.0	0.349	0.219	
M 802048	M 802011	57	51	70	79	3.5	3.3	22.9	0.55	1.1	0.60	0.406	0.23	
3877	3820	57	50	73	81	3.5	3.3	21.8	0.40	1.5	0.82	0.506	0.285	
3576	3525	49	48	75	81	0.8	3.3	19.5	0.31	2.0	1.1	0.532	0.304	
44162	44348	57	51	75	84	2.3	1.5	28.0	0.78	0.77	0.42	0.447	0.245	
HM 803146	HM 803110	60	53	74	85	3.5	3.3	25.6	0.55	1.1	0.60	0.579	0.322	
HM 803145	HM 803110	54	53	74	85	0.8	3.3	25.6	0.55	1.1	0.60	0.582	0.322	
4388	4335	57	51	77	85	3.5	3.3	24.6	0.28	2.1	1.2	0.789	0.459	
46162	46368	52	51	79	87	0.8	3.3	24.0	0.40	1.5	0.82	0.695	0.405	
HM 804840	HM 804810	61	54	81	91	3.5	3.3	26.1	0.55	1.1	0.60	0.726	0.354	
53162	53387	57	53	82	91	1.5	0.8	30.7	0.74	0.81	0.45	0.618	0.442	
12168	12303	51	48.5	68	73	1.5	1.5	17.7	0.51	1.2	0.65	0.228	0.098	
22168	22325	52	48.5	73	76	2.3	1.5	17.6	0.43	1.4	0.77	0.283	0.176	
25578	25520	53	49.5	74	77	2.3	0.8	17.6	0.33	1.8	0.99	0.383	0.203	
25578	25523	53	49.5	72	77	2.3	2.3	20.8	0.33	1.8	0.99	0.383	0.248	
26884	26823	55	48.5	69	73	3.5	1.5	18.0	0.32	1.9	1.0	0.337	0.136	
342 S	332	54	47.5	73	75	3.5	1.3	14.5	0.27	2.2	1.2	0.305	0.146	
25577	25523	55	49	72	77	3.5	2.3	20.8	0.33	1.8	0.99	0.381	0.248	
25577	25521	55	49	72	77	3.5	3.3	17.6	0.33	1.8	0.99	0.381	0.201	
* 16986	16929	51	48.5	67	71	1.5	1.3	17.2	0.44	1.4	0.74	0.24	0.106	
13175	13318	50	50	72	76	0.3	1.5	20.1	0.53	1.1	0.63	0.252	0.144	
25580	25520	57	50	74	77	3.5	0.8	17.6	0.33	1.8	0.99	0.359	0.203	
25580	25521	56	51	72	78	3.5	3.3	17.6	0.33	1.8	0.99	0.359	0.201	
3578	3525	57	51	75	81	3.5	3.3	19.5	0.31	2.0	1.1	0.477	0.304	
HM 803149	HM 803110	62	53	74	85	3.5	3.3	25.6	0.55	1.1	0.60	0.528	0.322	
3782	3720	58	52	82	88	3.5	3.2	22.4	0.34	1.8	0.97	0.678	0.292	
49176	49368	54	53	82	87	0.8	3.3	21.6	0.36	1.7	0.92	0.648	0.371	
49175	49368	59	53	82	87	3.5	3.3	21.6	0.36	1.7	0.92	0.645	0.371	
46176	46368	60	54	79	87	3.5	3.3	24.0	0.40	1.5	0.82	0.635	0.405	
438	432	57	51	83	87	3.5	2.3	18.6	0.28	2.1	1.2	0.555	0.384	

**Note** \* The maximum bore diameter is listed and its tolerance is negative (See Table 8.4.1 on Page A70).

# Single-Row Tapered Roller Bearings (Inch Design)

Bore Diameter 44.450 – 47.625 mm

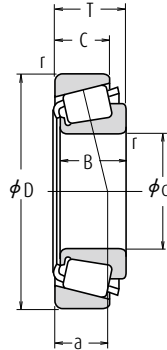

Boundary Dimensions (mm)							Basic Load Ratings (N) {kgf}				Limiting Speeds (min <sup>-1</sup> )		
d	D	T	B	C	Cone Cup		C <sub>r</sub>	C <sub>or</sub>	C <sub>r</sub>	C <sub>or</sub>	Grease	Oil	
					r	min.							
44.450	95.250	30.162	29.370	23.020	3.5	3.3	106 000	143 000	10 800	14 500	3 800	5 300	
	95.250	30.958	28.301	20.638	3.5	0.8	87 500	97 000	8 950	9 850	3 600	5 300	
	95.250	30.958	28.301	20.638	1.3	0.8	87 500	97 000	8 950	9 850	3 600	5 300	
	95.250	30.958	28.301	20.638	2.0	0.8	87 500	97 000	8 950	9 850	3 600	5 300	
	95.250	30.958	28.301	22.225	1.3	0.8	100 000	122 000	10 200	12 500	3 600	5 000	
	95.250	30.958	28.575	22.225	3.5	0.8	100 000	122 000	10 200	12 500	3 600	5 000	
	98.425	30.958	28.301	20.638	3.5	0.8	87 500	97 000	8 950	9 850	3 600	5 300	
	103.188	43.658	44.475	36.512	1.3	3.3	178 000	238 000	18 100	24 300	3 800	5 000	
	104.775	36.512	36.512	28.575	3.5	3.3	139 000	192 000	14 200	19 600	3 400	4 800	
	107.950	27.783	29.317	22.225	3.5	0.8	116 000	149 000	11 800	15 200	3 400	4 800	
44.983	111.125	30.162	26.909	20.638	3.5	3.3	92 500	110 000	9 450	11 200	3 200	4 300	
	114.300	44.450	44.450	34.925	3.5	3.3	172 000	205 000	17 500	20 900	3 600	4 800	
	44.983	82.931	23.812	25.400	19.050	1.5	0.8	76 500	99 000	7 800	10 100	4 500	6 000
	45.000	93.264	20.638	22.225	15.082	0.8	1.3	77 000	93 000	7 900	9 500	3 800	5 300
	45.230	79.985	19.842	20.638	15.080	2.0	1.3	62 000	78 500	6 300	8 000	4 500	6 000
	45.242	73.431	19.558	19.812	15.748	3.5	0.8	53 500	75 000	5 450	7 650	4 800	6 300
	77.788	19.842	19.842	15.080	3.5	0.8	56 000	71 000	5 700	7 250	4 500	6 300	
	77.788	21.430	19.842	16.667	3.5	0.8	56 000	71 000	5 700	7 250	4 500	6 300	
	45.618	82.931	23.812	25.400	19.050	3.5	0.8	76 500	99 000	7 800	10 100	4 500	6 000
	82.931	26.988	25.400	22.225	3.5	2.3	76 500	99 000	7 800	10 100	4 500	6 000	
46.000	75.000	18.000	18.000	14.000	2.3	1.5	51 000	71 500	5 200	7 300	4 500	6 300	
	46.038	79.375	17.462	17.462	13.495	2.8	1.5	46 000	57 000	4 700	5 800	4 500	6 000
	80.962	19.050	17.462	14.288	0.8	1.5	45 000	57 000	4 600	5 800	4 300	6 000	
	85.000	20.638	21.692	17.462	2.3	1.3	71 500	81 500	7 300	8 300	4 300	6 000	
	85.000	25.400	25.608	20.638	3.5	1.3	79 500	105 000	8 100	10 700	4 300	6 000	
	95.250	27.783	29.901	22.225	3.5	0.8	106 000	126 000	10 800	12 900	4 300	5 600	
	88.900	20.638	22.225	16.513	3.5	1.3	73 000	85 000	7 450	8 650	4 000	5 600	
	88.900	25.400	25.400	19.050	3.5	3.3	86 000	107 000	8 750	10 900	4 000	5 600	
	95.250	30.162	29.370	23.020	3.5	3.3	106 000	143 000	10 800	14 500	3 800	5 300	
	101.600	34.925	36.068	26.988	3.5	3.3	137 000	169 000	14 000	17 200	3 800	5 000	
47.625	111.125	30.162	26.909	20.638	3.5	3.3	92 500	110 000	9 450	11 200	3 200	4 300	
	112.712	30.162	26.909	20.638	3.5	3.3	92 500	110 000	9 450	11 200	3 200	4 300	
	117.475	33.338	31.750	23.812	3.5	3.3	137 000	156 000	13 900	15 900	3 200	4 300	
	123.825	36.512	32.791	25.400	3.5	3.3	143 000	160 000	14 600	16 400	3 000	4 000	

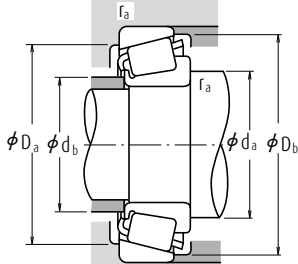

**Dynamic Equivalent Load**  $P = X F_r + Y F_a$

$F_a/F_r \leq e$		$F_a/F_r > e$	
X	Y	X	Y
1	0	0.4	$Y_1$

**Static Equivalent Load**

$P_0 = 0.5 F_r + Y_0 F_a$   
 When  $F_r > 0.5 F_r + Y_0 F_a$ , use  $P_0 = F_r$

The values of  $e$ ,  $Y_1$  and  $Y_0$  are given in the table below.

Bearing Numbers		Abutment and Fillet Dimensions (mm)					Eff. Load Centers (mm)	Constant	Axial Load Factors		Mass (kg)		
CONE	CUP	$d_a$	$d_b$	$D_a$	$D_b$	Cone Cup $r_a$ max.			a	e	$Y_1$	$Y_0$	CONE
HM 804843	HM 804810	63	57	81	91	3.5	3.3	26.1	0.55	1.1	0.60	0.677	0.354
53177	53375	63	53	81	89	3.5	0.8	30.7	0.74	0.81	0.45	0.572	0.365
53176	53375	59	53	81	89	1.3	0.8	30.7	0.74	0.81	0.45	0.574	0.365
53178	53375	60	53	81	89	2	0.8	30.7	0.74	0.81	0.45	0.574	0.365
HM 903247	HM 903210	61	54	81	91	1.3	0.8	31.5	0.74	0.81	0.45	0.651	0.389
HM 903249	HM 903210	65	54	81	91	3.5	0.8	31.5	0.74	0.81	0.45	0.635	0.389
53177	53387	63	53	82	91	3.5	0.8	30.7	0.74	0.81	0.45	0.568	0.442
5356	5335	58	56	89	97	1.3	3.3	27.0	0.30	2.0	1.1	1.23	0.637
HM 807040	HM 807010	66	59	89	100	3.5	3.3	29.7	0.49	1.2	0.68	1.14	0.502
460	453 A	60	54	97	100	3.5	0.8	20.7	0.34	1.8	0.98	0.93	0.42
55175	55437	67	60	92	105	3.5	3.3	37.3	0.88	0.68	0.37	0.867	0.514
65385	65320	65	59	97	107	3.5	3.3	32.2	0.43	1.4	0.77	1.39	0.894
25584	25520	53	51	74	77	1.5	0.8	17.6	0.33	1.8	0.99	0.354	0.203
376	374	54	54	85	88	0.8	1.3	17.1	0.34	1.8	0.97	0.492	0.174
17887	17831	57	52	68	74	2	1.3	15.9	0.37	1.6	0.90	0.274	0.136
LM 102949	LM 102910	56	50	68	70	3.5	0.8	14.6	0.31	2.0	1.1	0.213	0.102
LM 603049	LM 603011	57	50	71	74	3.5	0.8	17.2	0.43	1.4	0.77	0.249	0.119
LM 603049	LM 603012	57	50	70	74	3.5	0.8	18.8	0.43	1.4	0.77	0.249	0.137
25590	25520	58	51	74	77	3.5	0.8	17.6	0.33	1.8	0.99	0.343	0.203
25590	25523	58	51	72	77	3.5	2.3	20.8	0.33	1.8	0.99	0.343	0.248
* LM 503349	** LM 503310	55	51	67	71	2.3	1.5	15.9	0.40	1.5	0.82	0.209	0.096
18690	18620	56	51	71	74	2.8	1.5	15.5	0.37	1.6	0.88	0.211	0.126
13181	13318	52	52	72	76	0.8	1.5	20.1	0.53	1.1	0.63	0.236	0.144
359 S	354 A	55	51	77	80	2.3	1.3	15.4	0.31	2.0	1.1	0.343	0.162
2984	2924	58	52	76	80	3.5	1.3	19.0	0.35	1.7	0.95	0.397	0.223
436	432 A	59	52	84	87	3.5	0.8	18.6	0.28	2.1	1.2	0.536	0.381
369 A	362 A	60	53	81	84	3.5	1.3	16.6	0.32	1.9	1.0	0.381	0.166
M 804049	M 804010	63	56	77	85	3.5	3.3	23.8	0.55	1.1	0.60	0.455	0.218
HM 804846	HM 804810	66	57	81	91	3.5	3.3	26.1	0.55	1.1	0.60	0.626	0.354
528	522	62	55	89	95	3.5	3.3	22.1	0.29	2.1	1.2	0.894	0.416
55187	55437	69	62	92	105	3.5	3.3	37.3	0.88	0.68	0.37	0.817	0.514
55187	55443	69	62	92	106	3.5	3.3	37.3	0.88	0.68	0.37	0.816	0.554
66187	66462	66	62	100	111	3.5	3.3	32.1	0.63	0.96	0.53	1.19	0.552
72187	72487	72	66	102	116	3.5	3.3	37.0	0.74	0.81	0.45	1.29	0.79

- Notes**
- \* The maximum bore diameter is listed and its tolerance is negative (See Table 8.4.1 on Page A70).
  - \*\* The maximum outside diameter is listed and its tolerance is negative (See Table 8.4.2 on Pages A70 and A71).



# Single-Row Tapered Roller Bearings (Inch Design)

Bore Diameter 48.412 – 52.388 mm

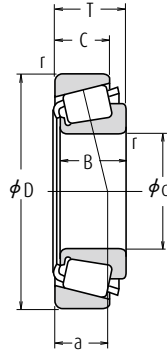

Boundary Dimensions (mm)							Basic Load Ratings (N) {kgf}				Limiting Speeds (min <sup>-1</sup> )	
d	D	T	B	C	Cone	Cup	C <sub>r</sub>	C <sub>or</sub>	C <sub>r</sub>	C <sub>or</sub>	Grease	Oil
					r	r						
					min.	min.						
48.412	95.250	30.162	29.370	23.020	3.5	3.3	106 000	143 000	10 800	14 500	3 800	5 300
	95.250	30.162	29.370	23.020	2.3	3.3	106 000	143 000	10 800	14 500	3 800	5 300
49.212	104.775	36.512	36.512	28.575	3.5	0.8	139 000	192 000	14 200	19 600	3 400	4 800
	114.300	44.450	44.450	36.068	3.5	3.3	196 000	243 000	20 000	24 800	3 400	4 800
50.000	82.000	21.500	21.500	17.000	3.0	0.5	71 000	96 000	7 250	9 800	4 300	5 600
	82.550	21.590	22.225	16.510	0.5	1.3	71 000	96 000	7 250	9 800	4 300	5 600
	88.900	20.638	22.225	16.513	2.3	1.3	73 000	85 000	7 450	8 650	4 000	5 600
	90.000	28.000	28.000	23.000	3.0	2.5	104 000	136 000	10 600	13 900	4 000	5 600
50.800	105.000	37.000	36.000	29.000	3.0	2.5	139 000	192 000	14 200	19 600	3 400	4 800
	80.962	18.258	18.258	14.288	1.5	1.5	53 000	81 000	5 400	8 250	4 300	5 600
	82.550	23.622	22.225	18.542	3.5	0.8	71 000	96 000	7 250	9 800	4 300	5 600
	82.931	21.590	22.225	16.510	3.5	1.3	71 000	96 000	7 250	9 800	4 300	5 600
	85.000	17.462	17.462	13.495	3.5	1.5	48 500	63 000	4 950	6 450	4 300	5 600
	85.725	19.050	18.263	12.700	1.5	1.5	42 500	54 000	4 350	5 500	4 000	5 300
	88.900	20.638	22.225	16.513	3.5	1.3	73 000	85 000	7 450	8 650	4 000	5 600
	88.900	20.638	22.225	16.513	1.5	1.3	73 000	85 000	7 450	8 650	4 000	5 600
	92.075	24.608	25.400	19.845	3.5	0.8	84 500	117 000	8 600	11 900	4 000	5 300
	93.264	30.162	30.302	23.812	0.8	0.8	103 000	136 000	10 500	13 900	3 800	5 300
	93.264	30.162	30.302	23.812	3.5	0.8	103 000	136 000	10 500	13 900	3 800	5 300
	95.250	27.783	28.575	22.225	3.5	2.3	110 000	144 000	11 200	14 700	3 800	5 300
	101.600	31.750	31.750	25.400	3.5	3.3	118 000	150 000	12 100	15 200	3 600	5 000
	101.600	34.925	36.068	26.988	0.8	3.3	137 000	169 000	14 000	17 200	3 800	5 000
	101.600	34.925	36.068	26.988	3.5	3.3	137 000	169 000	14 000	17 200	3 800	5 000
	104.775	36.512	36.512	28.575	3.5	0.8	139 000	192 000	14 200	19 600	3 400	4 800
	104.775	36.512	36.512	28.575	3.5	3.3	139 000	192 000	14 200	19 600	3 400	4 800
	108.966	34.925	36.512	26.988	3.5	3.3	145 000	181 000	14 700	18 500	3 600	4 800
	111.125	30.162	26.909	20.638	3.5	3.3	113 000	152 000	11 500	15 400	3 000	4 300
	111.125	30.162	26.909	20.638	3.5	3.3	92 500	110 000	9 450	11 200	3 200	4 300
	123.825	36.512	32.791	25.400	3.5	3.3	162 000	199 000	16 500	20 300	2 800	4 000
	123.825	36.512	32.791	25.400	3.5	3.3	143 000	160 000	14 600	16 400	3 000	4 000
	127.000	44.450	44.450	34.925	3.5	3.3	199 000	258 000	20 200	26 300	3 000	4 000
	127.000	50.800	52.388	41.275	3.5	3.3	236 000	300 000	24 000	31 000	3 200	4 300
52.388	92.075	24.608	25.400	19.845	3.5	0.8	84 500	117 000	8 600	11 900	4 000	5 300
	100.000	25.000	22.225	21.824	2.3	2.0	77 000	93 000	7 900	9 500	3 800	5 300
	111.125	30.162	26.909	20.638	3.5	3.3	92 500	110 000	9 450	11 200	3 200	4 300

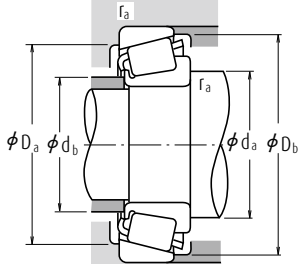

**Dynamic Equivalent Load**  $P = X F_r + Y F_a$

$F_a/F_r \leq e$		$F_a/F_r > e$	
X	Y	X	Y
1	0	0.4	$Y_1$

**Static Equivalent Load**

$$P_0 = 0.5 F_r + Y_0 F_a$$

When  $F_r > 0.5 F_r + Y_0 F_a$ , use  $P_0 = F_r$

The values of  $e$ ,  $Y_1$  and  $Y_0$  are given in the table below.

Bearing Numbers		Abutment and Fillet Dimensions (mm)					Cone	Cup	Eff. Load Centers (mm)	Constant	Axial Load Factors		Mass (kg)	
CONE	CUP	$d_a$	$d_b$	$D_a$	$D_b$	$r_a$ max.					a	e	$Y_1$	$Y_0$
HM 804849	HM 804810	66	57	81	91	3.5	3.3	26.1	0.55	1.1	0.60	0.61	0.354	
HM 804848	HM 804810	63	57	81	91	2.3	3.3	26.1	0.55	1.1	0.60	0.614	0.354	
HM 807044	HM 807011	69	63	91	100	3.5	0.8	29.7	0.49	1.2	0.68	1.03	0.508	
HH 506348	HH 506310	71	61	97	107	3.5	3.3	30.8	0.40	1.5	0.82	1.43	0.837	
▲ JLM 104948	▲ JLM 104910	60	55	76	78	3	0.5	16.1	0.31	2.0	1.1	0.306	0.129	
* LM 104947 A	LM 104911	55	55	75	78	0.5	1.3	15.7	0.31	2.0	1.1	0.316	0.133	
366	362 A	59	55	81	84	2.3	1.3	16.6	0.32	1.9	1.0	0.351	0.166	
▲ JM 205149	▲ JM 205110	62	57	80	85	3	2.5	19.9	0.33	1.8	1.0	0.507	0.246	
▲ JHM 807045	▲ JHM 807012	69	63	90	100	3	2.5	29.7	0.49	1.2	0.68	1.01	0.523	
L 305649	L 305610	58	56	73	77	1.5	1.5	15.7	0.36	1.7	0.93	0.239	0.119	
LM 104949	LM 104911 A	62	55	75	78	3.5	0.8	17.8	0.31	2.0	1.1	0.303	0.156	
LM 104949	LM 104912	62	55	75	78	3.5	1.3	15.7	0.31	2.0	1.1	0.301	0.14	
18790	18720	62	56	77	80	3.5	1.5	16.7	0.41	1.5	0.81	0.239	0.136	
18200	18337	59	56	76	81	1.5	1.5	21.0	0.57	1.1	0.58	0.268	0.136	
368 A	362 A	62	56	81	84	3.5	1.3	16.6	0.32	1.9	1.0	0.338	0.166	
368	362 A	58	56	81	84	1.5	1.3	16.6	0.32	1.9	1.0	0.341	0.166	
28580	28521	63	57	83	87	3.5	0.8	20.0	0.38	1.6	0.87	0.46	0.247	
3775	3730	58	58	84	88	0.8	0.8	22.4	0.34	1.8	0.97	0.568	0.297	
3780	3730	64	58	84	88	3.5	0.8	22.4	0.34	1.8	0.97	0.564	0.297	
33889	33821	64	58	85	90	3.5	2.3	19.8	0.33	1.8	1.0	0.601	0.267	
49585	49520	66	59	88	96	3.5	3.3	23.4	0.40	1.5	0.82	0.744	0.389	
529	522	59	58	89	95	0.8	3.3	22.1	0.29	2.1	1.2	0.822	0.416	
529 X	522	65	58	89	95	3.5	3.3	22.1	0.29	2.1	1.2	0.819	0.416	
HM 807046	HM 807011	70	63	91	100	3.5	0.8	29.7	0.49	1.2	0.68	0.992	0.508	
HM 807046	HM 807010	70	63	89	100	3.5	3.3	29.7	0.49	1.2	0.68	0.993	0.502	
59200	59429	68	61	93	101	3.5	3.3	25.4	0.40	1.5	0.82	0.943	0.594	
55200 C	55437	71	65	92	105	3.5	3.3	37.6	0.88	0.68	0.37	0.845	0.514	
55200	55437	71	64	92	105	3.5	3.3	37.3	0.88	0.68	0.37	0.767	0.514	
72200 C	72487	77	67	102	116	3.5	3.3	38.0	0.74	0.81	0.45	1.33	0.79	
72200	72487	74	66	102	116	3.5	3.3	37.0	0.74	0.81	0.45	1.22	0.79	
65200	65500	75	69	107	119	3.5	3.3	35.0	0.49	1.2	0.68	1.86	1.03	
6279	6220	71	65	108	117	3.5	3.3	30.7	0.30	2.0	1.1	2.08	1.22	
28584	28521	65	58	83	87	3.5	0.8	20.0	0.38	1.6	0.87	0.435	0.247	
377	372	62	58	86	90	2.3	2	21.4	0.34	1.8	0.97	0.392	0.435	
55206	55437	72	64	92	105	3.5	3.3	37.3	0.88	0.68	0.37	0.737	0.514	

**Notes** \* The maximum bore diameter is listed and its tolerance is negative (See Table 8.4.1 on Page A70).

▲ The tolerances are listed in Tables 2, 3 and 4 on Pages B139 and B140.

# Single-Row Tapered Roller Bearings (Inch Design)

Bore Diameter 53.975 – 58.738 mm

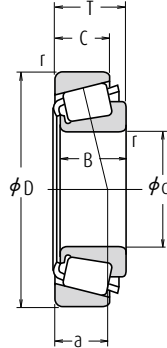

d	Boundary Dimensions (mm)					Cone		Cup		Basic Load Ratings (N) {kgf}				Limiting Speeds (min <sup>-1</sup> )	
	D	T	B	C	r	r	r	r	C <sub>r</sub>	C <sub>0r</sub>	C <sub>r</sub>	C <sub>0r</sub>	Grease	Oil	
53.975	104.775	39.688	40.157	33.338	3.5	3.3	148 000	207 000	15 100	21 100	3 600	4 800			
	107.950	36.512	36.957	28.575	3.5	3.3	144 000	182 000	14 700	18 500	3 600	4 800			
	122.238	33.338	31.750	23.812	3.5	3.3	135 000	156 000	13 800	15 900	3 000	4 000			
	123.825	36.512	32.791	25.400	3.5	3.3	143 000	160 000	14 600	16 400	3 000	4 000			
	123.825	36.512	32.791	25.400	3.5	3.3	162 000	199 000	16 500	20 300	2 800	4 000			
	123.825	38.100	36.678	30.162	3.5	3.3	161 000	221 000	16 400	22 500	3 000	4 000			
	127.000	44.450	44.450	34.925	3.5	3.3	199 000	258 000	20 200	26 300	3 000	4 000			
	127.000	50.800	52.388	41.275	3.5	3.3	236 000	300 000	24 000	31 000	3 200	4 300			
55.000	130.175	36.512	33.338	23.812	3.5	3.3	133 000	154 000	13 600	15 700	2 600	3 600			
	90.000	23.000	23.000	18.500	1.5	0.5	79 000	111 000	8 050	11 300	3 800	5 300			
	95.000	29.000	29.000	23.500	1.5	2.5	111 000	152 000	11 300	15 500	3 800	5 000			
	96.838	21.000	21.946	15.875	2.3	0.8	80 500	100 000	8 200	10 200	3 600	5 000			
	110.000	39.000	39.000	32.000	3.0	2.5	177 000	225 000	18 000	23 000	3 400	4 500			
	115.000	41.021	41.275	31.496	3.0	3.0	172 000	214 000	17 500	21 800	3 200	4 500			
	97.630	24.608	24.608	19.446	3.5	0.8	89 000	129 000	9 100	13 100	3 600	5 000			
	122.238	43.658	43.764	36.512	1.3	3.3	198 000	292 000	20 200	29 700	3 000	4 000			
55.562	123.825	36.512	32.791	25.400	3.5	3.3	143 000	160 000	14 600	16 400	3 000	4 000			
	123.825	36.512	32.791	25.400	3.5	3.3	162 000	199 000	16 500	20 300	2 800	4 000			
	96.838	21.000	21.946	15.875	3.5	0.8	80 500	100 000	8 200	10 200	3 600	5 000			
	96.838	25.400	21.946	20.275	3.5	2.3	80 500	100 000	8 200	10 200	3 600	5 000			
	98.425	21.000	21.946	17.826	3.5	0.8	80 500	100 000	8 200	10 200	3 600	5 000			
	104.775	30.162	29.317	24.605	3.5	3.3	116 000	149 000	11 800	15 200	3 400	4 800			
	104.775	30.162	29.317	24.605	2.3	3.3	116 000	149 000	11 800	15 200	3 400	4 800			
	104.775	30.162	30.958	23.812	0.8	3.3	130 000	170 000	13 300	17 400	3 400	4 800			
57.150	104.775	30.162	30.958	23.812	0.8	0.8	130 000	170 000	13 300	17 400	3 400	4 800			
	122.238	33.338	31.750	23.812	3.5	3.3	135 000	156 000	13 800	15 900	3 000	4 000			
	123.825	36.512	32.791	25.400	3.5	3.3	162 000	199 000	16 500	20 300	2 800	4 000			
	123.825	38.100	36.678	30.162	3.5	3.3	161 000	221 000	16 400	22 500	3 000	4 000			
	140.030	36.512	33.236	23.520	3.5	2.3	152 000	183 000	15 500	18 700	2 600	3 600			
	144.983	36.000	33.236	23.007	3.5	3.5	152 000	183 000	15 500	18 700	2 600	3 600			
	149.225	53.975	54.229	44.450	3.5	3.3	287 000	410 000	29 300	41 500	2 600	3 400			
	96.838	21.000	21.946	15.875	3.5	0.8	80 500	100 000	8 200	10 200	3 600	5 000			
	57.531	96.838	21.000	21.946	15.875	3.5	0.8	80 500	100 000	8 200	10 200	3 600	5 000		
	58.738	112.712	33.338	30.048	26.988	3.5	3.3	120 000	173 000	12 200	17 700	3 200	4 300		

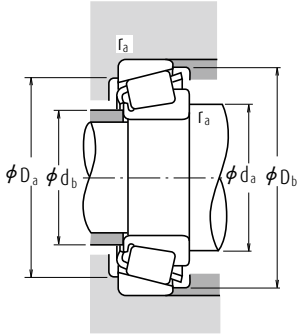

**Dynamic Equivalent Load**  $P = X F_r + Y F_a$

$F_a/F_r \leq e$		$F_a/F_r > e$	
X	Y	X	Y
1	0	0.4	$Y_1$

**Static Equivalent Load**

$$P_0 = 0.5 F_r + Y_0 F_a$$

When  $F_r > 0.5 F_r + Y_0 F_a$ , use  $P_0 = F_r$

The values of  $e$ ,  $Y_1$  and  $Y_0$  are given in the table below.

Bearing Numbers		Abutment and Fillet Dimensions (mm)						Eff. Load Centers (mm)	Constant	Axial Load Factors		Mass (kg)	
CONE	CUP	$d_a$	$d_b$	$D_a$	$D_b$	Cone $r_a$ max.	Cup			$Y_1$	$Y_0$	approx. CONE	CUP
4595	4535	70	63	90	99	3.5	3.3	27.4	0.34	1.79	0.98	0.989	0.589
539	532 X	68	61	94	100	3.5	3.3	24.3	0.30	2.0	1.1	0.88	0.57
66584	66520	75	68	105	116	3.5	3.3	34.3	0.67	0.90	0.50	1.2	0.558
72212	72487	77	66	102	116	3.5	3.3	37.0	0.74	0.81	0.45	1.16	0.79
72212 C	72487	79	67	102	116	3.5	3.3	38.0	0.74	0.81	0.45	1.27	0.79
557 S	552 A	71	65	109	116	3.5	3.3	28.8	0.35	1.7	0.95	1.49	0.764
65212	65500	77	71	107	119	3.5	3.3	35.0	0.49	1.2	0.68	1.76	1.03
6280	6220	74	67	108	117	3.5	3.3	30.7	0.30	2.0	1.1	1.97	1.22
HM911242	HM911210	79	74	109	124	3.5	3.3	42.2	0.82	0.73	0.40	1.45	0.725
▲ JLM506849	▲ JLM506810	63	61	82	86	1.5	0.5	19.7	0.40	1.5	0.82	0.378	0.186
▲ JM207049	▲ JM207010	64	62	85	91	1.5	2.5	21.3	0.33	1.8	0.99	0.59	0.26
385	382 A	65	61	89	92	2.3	0.8	17.6	0.35	1.7	0.93	0.455	0.179
▲ JH307749	▲ JH307710	71	64	97	104	3	2.5	27.2	0.35	1.7	0.95	1.13	0.567
622 X	614 X	70	64	101	108	3	3	26.6	0.31	1.9	1.1	1.3	0.597
28680	28622	68	62	88	92	3.5	0.8	21.3	0.40	1.5	0.82	0.499	0.27
5566	5535	70	68	106	116	1.3	3.3	29.9	0.36	1.7	0.92	1.76	0.815
72218	72487	78	66	102	116	3.5	3.3	37.0	0.74	0.81	0.45	1.12	0.79
72218 C	72487	80	67	102	116	3.5	3.3	38.0	0.74	0.81	0.45	1.23	0.79
387 A	382 A	69	62	89	92	3.5	0.8	17.6	0.35	1.7	0.93	0.42	0.179
387	382 A	66	62	89	92	2.3	0.8	17.6	0.35	1.7	0.93	0.423	0.179
387 A	382 S	69	62	87	91	3.5	2.3	22.0	0.35	1.7	0.93	0.42	0.249
387 A	382	69	62	90	92	3.5	0.8	17.6	0.35	1.7	0.93	0.42	0.226
469	453 X	70	63	92	98	3.5	3.3	23.1	0.34	1.8	0.98	0.692	0.376
462	453 X	67	63	92	98	2.3	3.3	23.1	0.34	1.8	0.98	0.694	0.376
45289	45220	65	65	93	99	0.8	3.3	21.9	0.33	1.8	0.99	0.752	0.347
45289	45221	65	65	95	99	0.8	0.8	21.9	0.33	1.8	0.99	0.76	0.35
66587	66520	77	71	105	116	3.5	3.3	34.3	0.67	0.90	0.50	1.14	0.558
72225 C	72487	81	67	102	116	3.5	3.3	38.0	0.74	0.81	0.45	1.19	0.79
555 S	552 A	83	68	109	116	3.5	3.3	28.8	0.35	1.7	0.95	1.41	0.764
78225	78511	83	77	117	132	3.5	2.3	44.2	0.87	0.69	0.38	1.67	0.926
78225	78571	83	77	118	132	3.5	3.5	43.6	0.87	0.69	0.38	1.68	1.08
6455	6420	81	75	129	140	3.5	3.3	39.0	0.36	1.7	0.91	3.49	1.63
388 A	382 A	69	63	89	92	3.5	0.8	17.6	0.35	1.7	0.93	0.416	0.179
3981	3926	73	67	98	106	3.5	3.3	28.7	0.40	1.5	0.82	0.899	0.541

**Note** ▲ The tolerances are listed in Tables 2, 3 and 4 on Pages B139 and B140.

# Single-Row Tapered Roller Bearings (Inch Design)

Bore Diameter 60.000 – 64.963 mm

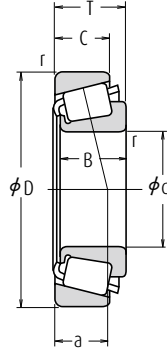

Boundary Dimensions (mm)							Basic Load Ratings (N) {kgf}				Limiting Speeds (min <sup>-1</sup> )	
d	D	T	B	C	Cone	Cup	C <sub>r</sub>	C <sub>0r</sub>	C <sub>r</sub>	C <sub>0r</sub>	Grease	Oil
					r	r						
					min.	min.						
<b>60.000</b>	95.000	24.000	24.000	19.000	5.0	2.5	86 500	125 000	8 800	12 800	3 600	5 000
	104.775	21.433	22.000	15.875	2.3	2.0	83 500	107 000	8 500	10 900	3 400	4 500
	110.000	22.000	21.996	18.824	0.8	1.3	85 500	113 000	8 750	11 500	3 200	4 300
	122.238	33.338	31.750	23.812	3.5	3.3	135 000	156 000	13 800	15 900	3 000	4 000
<b>60.325</b>	100.000	25.400	25.400	19.845	3.5	3.3	91 000	135 000	9 250	13 700	3 400	4 800
	101.600	25.400	25.400	19.845	3.5	3.3	91 000	135 000	9 250	13 700	3 400	4 800
	122.238	38.100	36.678	30.162	2.3	3.3	161 000	221 000	16 400	22 500	3 000	4 000
	122.238	38.100	38.354	29.718	8.0	1.5	188 000	245 000	19 200	25 000	3 000	4 000
	122.238	43.658	43.764	36.512	0.8	3.3	198 000	292 000	20 200	29 700	3 000	4 000
	127.000	44.450	44.450	34.925	3.5	3.3	199 000	258 000	20 200	26 300	3 000	4 000
	130.175	41.275	41.275	31.750	3.5	3.3	195 000	263 000	19 800	26 800	2 800	3 800
	135.755	53.975	56.007	44.450	3.5	3.3	264 000	355 000	27 000	36 000	2 800	3 800
<b>61.912</b>	136.525	46.038	46.038	36.512	3.5	3.3	233 000	370 000	23 800	37 500	2 600	3 400
	146.050	41.275	39.688	25.400	3.5	3.3	193 000	225 000	19 700	22 900	2 400	3 400
	152.400	47.625	46.038	31.750	3.5	3.3	237 000	267 000	24 200	27 300	2 400	3 400
<b>63.500</b>	94.458	19.050	19.050	15.083	1.5	1.5	59 000	100 000	6 050	10 200	3 600	4 800
	104.775	21.433	22.000	15.875	2.0	2.0	83 500	107 000	8 500	10 900	3 400	4 500
	107.950	25.400	25.400	19.050	1.5	3.3	90 000	138 000	9 150	14 100	3 200	4 300
	110.000	22.000	21.996	18.824	3.5	1.3	85 500	113 000	8 750	11 500	3 200	4 300
	110.000	22.000	21.996	18.824	1.5	1.3	85 500	113 000	8 750	11 500	3 200	4 300
	112.712	30.162	30.048	23.812	3.5	3.2	120 000	173 000	12 200	17 700	3 200	4 300
	112.712	30.162	30.162	23.812	3.5	3.3	142 000	202 000	14 500	20 600	3 200	4 300
	112.712	33.338	30.048	26.988	3.5	3.3	120 000	173 000	12 200	17 700	3 200	4 300
	122.238	38.100	38.354	29.718	7.0	3.3	188 000	245 000	19 200	25 000	3 000	4 000
	122.238	38.100	38.354	29.718	7.0	1.5	188 000	245 000	19 200	25 000	3 000	4 000
	122.238	38.100	38.354	29.718	3.5	1.5	188 000	245 000	19 200	25 000	3 000	4 000
	122.238	43.658	43.764	36.512	3.5	3.3	198 000	292 000	20 200	29 700	3 000	4 000
	123.825	38.100	36.678	30.162	3.5	3.3	161 000	221 000	16 400	22 500	3 000	4 000
	127.000	36.512	36.170	28.575	3.5	3.3	166 000	234 000	16 900	23 900	2 800	3 800
	130.175	41.275	41.275	31.750	3.5	3.3	195 000	263 000	19 800	26 800	2 800	3 800
	136.525	36.512	33.236	23.520	2.3	3.3	152 000	183 000	15 500	18 700	2 600	3 600
	136.525	41.275	41.275	31.750	3.5	3.3	195 000	263 000	19 800	26 800	2 800	3 800
	140.030	36.512	33.236	23.520	2.3	2.3	152 000	183 000	15 500	18 700	2 600	3 600
<b>64.963</b>	127.000	36.512	36.170	28.575	3.5	3.3	166 000	234 000	16 900	23 900	2 800	3 800

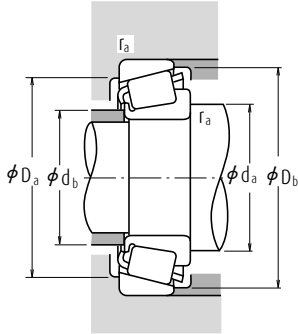

**Dynamic Equivalent Load**  $P = X F_r + Y F_a$

$F_a/F_r \leq e$		$F_a/F_r > e$	
X	Y	X	Y
1	0	0.4	$Y_1$

**Static Equivalent Load**

$$P_0 = 0.5 F_r + Y_0 F_a$$

When  $F_r > 0.5 F_r + Y_0 F_a$ , use  $P_0 = F_r$

The values of  $e$ ,  $Y_1$  and  $Y_0$  are given in the table below.

Bearing Numbers		Abutment and Fillet Dimensions (mm)						Eff. Load Centers (mm)	Constant	Axial Load Factors		Mass (kg)	
CONE	CUP	$d_a$	$d_b$	$D_a$	$D_b$	Cone $r_a$ max.	Cup			$a$	$e$	$Y_1$	$Y_0$
▲ JLM 508748	▲ JLM 508710	75	66	85	91	5	2.5	21.6	0.40	1.5	0.82	0.43	0.20
* 39236	39412	71	67	96	100	2.3	2	20.0	0.39	1.5	0.85	0.559	0.186
397	394 A	69	68	101	104	0.8	1.3	20.9	0.40	1.5	0.82	0.642	0.263
66585	66520	79	73	105	116	3.5	3.3	34.3	0.67	0.90	0.50	1.07	0.558
28985	28921	73	67	89	96	3.5	3.3	22.9	0.43	1.4	0.78	0.538	0.232
28985	28920	73	67	90	97	3.5	3.3	22.9	0.43	1.4	0.78	0.538	0.272
558	553 X	73	69	108	115	2.3	3.3	28.8	0.35	1.7	0.95	1.33	0.692
HM 212044	HM 212010	85	70	110	116	8	1.5	27.0	0.34	1.8	0.98	1.43	0.604
5582	5535	73	72	106	116	0.8	3.3	29.9	0.36	1.7	0.92	1.61	0.815
65237	65500	82	71	107	119	3.5	3.3	35.0	0.49	1.2	0.68	1.56	1.03
637	633	78	72	116	124	3.5	3.3	29.9	0.36	1.7	0.91	1.87	0.712
6376	6320	81	74	117	126	3.5	3.3	35.0	0.32	1.8	1.0	2.45	1.39
H 715334	H 715311	84	78	119	132	3.5	3.3	37.1	0.47	1.3	0.70	2.51	0.961
H 913842	H 913810	90	82	124	138	3.5	3.3	44.4	0.78	0.77	0.42	2.2	0.898
9180	9121	90	81	130	145	3.5	3.3	44.3	0.66	0.92	0.50	2.77	1.21
L 610549	L 610510	71	69	86	91	1.5	1.5	19.6	0.42	1.4	0.78	0.306	0.154
39250	39412	73	69	96	100	2	2	20.0	0.39	1.5	0.85	0.501	0.186
29586	29520	73	71	96	103	1.5	3.3	24.0	0.46	1.3	0.72	0.661	0.281
395	394 A	77	70	101	104	3.5	1.3	20.9	0.40	1.5	0.82	0.58	0.263
390 A	394 A	73	70	101	104	1.5	1.3	20.9	0.40	1.5	0.82	0.583	0.263
3982	3920	77	71	99	106	3.5	3.2	25.5	0.40	1.5	0.82	0.789	0.454
39585	39520	77	71	101	107	3.5	3.3	23.5	0.34	1.8	0.97	0.899	0.359
3982	3926	78	71	98	106	3.5	3.3	28.7	0.40	1.5	0.82	0.789	0.541
HM 212047	HM 212011	87	73	108	116	7	3.3	26.9	0.34	1.8	0.98	1.34	0.598
HM 212047	HM 212010	87	73	110	116	7	1.5	26.9	0.34	1.8	0.98	1.34	0.604
HM 212046	HM 212010	80	73	110	116	3.5	1.5	26.9	0.34	1.8	0.98	1.35	0.604
5584	5535	81	75	106	116	3.5	3.3	29.9	0.36	1.7	0.92	1.5	0.815
559	522 A	78	73	109	116	3.5	3.3	28.8	0.35	1.7	0.95	1.23	0.764
565	563	80	73	112	120	3.5	3.3	28.3	0.36	1.6	0.91	1.46	0.655
639	633	81	74	116	124	3.5	3.3	29.9	0.36	1.7	0.91	1.77	0.712
78250	78537	85	79	115	130	2.3	3.3	44.2	0.87	0.69	0.38	1.51	0.782
639	632	79	76	119	125	3.5	3.3	29.9	0.36	1.7	0.91	1.77	1.04
78250	78551	85	79	117	132	2.3	2.3	44.2	0.87	0.69	0.38	1.51	0.926
569	563	81	74	112	120	3.5	3.3	28.3	0.36	1.6	0.91	1.41	0.655

**Notes** \* The maximum bore diameter is listed and its tolerance is negative (See Table 8.4.1 on Page A70).

▲ The tolerances are listed in Tables 2, 3 and 4 on Pages B139 and B140.

# Single-Row Tapered Roller Bearings (Inch Design)

Bore Diameter 65.000 - 69.850 mm

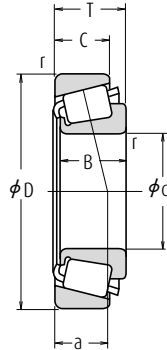

Boundary Dimensions (mm)							Basic Load Ratings (N) {kgf}				Limiting Speeds (min <sup>-1</sup> )	
d	D	T	B	C	Cone	Cup	C <sub>r</sub>	C <sub>0r</sub>	C <sub>r</sub>	C <sub>0r</sub>	Grease	Oil
					r	r						
					min.	min.						
65.000	105.000	24.000	23.000	18.500	3.0	1.0	93 000	126 000	9 500	12 900	3 400	4 500
	110.000	28.000	28.000	22.500	3.0	2.5	120 000	173 000	12 200	17 700	3 200	4 300
	120.000	29.002	29.007	23.444	2.3	3.3	123 000	169 000	12 500	17 200	3 000	4 000
	120.000	39.000	38.500	32.000	3.0	2.5	185 000	249 000	18 800	25 400	3 000	4 000
65.088	135.755	53.975	56.007	44.450	3.5	3.3	264 000	355 000	27 000	36 000	2 800	3 800
	136.525	46.038	46.038	36.512	3.5	3.3	233 000	370 000	23 800	37 500	2 600	3 400
66.675	110.000	22.000	21.996	18.824	0.8	1.3	85 500	113 000	8 750	11 500	3 200	4 300
	110.000	22.000	21.996	18.824	3.5	1.3	85 500	113 000	8 750	11 500	3 200	4 300
	112.712	30.162	30.048	23.812	3.5	3.2	120 000	173 000	12 200	17 700	3 200	4 300
	112.712	30.162	30.048	23.812	5.5	3.2	120 000	173 000	12 200	17 700	3 200	4 300
	112.712	30.162	30.162	23.812	3.5	0.8	142 000	202 000	14 500	20 600	3 200	4 300
	112.712	30.162	30.162	23.812	3.5	3.3	142 000	202 000	14 500	20 600	3 200	4 300
	117.475	30.162	30.162	23.812	3.5	3.3	119 000	179 000	12 200	18 300	3 000	4 000
	122.238	38.100	36.678	30.162	3.5	3.3	161 000	221 000	16 400	22 500	3 000	4 000
	122.238	38.100	38.354	29.718	3.5	1.5	188 000	245 000	19 200	25 000	3 000	4 000
	122.238	38.100	38.354	29.718	3.5	3.3	188 000	245 000	19 200	25 000	3 000	4 000
	123.825	38.100	36.678	30.162	3.5	3.3	161 000	221 000	16 400	22 500	3 000	4 000
	136.525	46.038	46.038	36.512	3.5	3.3	233 000	370 000	23 800	37 500	2 600	3 400
68.262	110.000	22.000	21.996	18.824	2.3	1.3	85 500	113 000	8 750	11 500	3 200	4 300
	120.000	29.795	29.007	24.237	3.5	2.0	123 000	169 000	12 500	17 200	3 000	4 000
	122.238	38.100	36.678	30.162	3.5	3.3	161 000	221 000	16 400	22 500	3 000	4 000
	127.000	36.512	36.170	28.575	3.5	3.3	166 000	234 000	16 900	23 900	2 800	3 800
	136.525	41.275	41.275	31.750	3.5	3.3	229 000	297 000	23 300	30 500	2 600	3 600
	136.525	46.038	46.038	36.512	3.5	3.3	233 000	370 000	23 800	37 500	2 600	3 400
	152.400	47.625	46.038	31.750	3.5	3.3	237 000	267 000	24 200	27 300	2 400	3 400
	69.850	112.712	22.225	21.996	15.875	1.5	0.8	85 000	113 000	8 650	11 500	3 000
112.712		25.400	25.400	19.050	1.5	3.3	96 000	152 000	9 800	15 500	2 800	4 000
117.475		30.162	30.162	23.812	3.5	3.3	119 000	179 000	12 200	18 300	3 000	4 000
120.000		32.545	32.545	26.195	3.5	3.3	152 000	225 000	15 500	22 900	3 000	4 000
120.650		25.400	25.400	19.050	1.5	3.3	96 000	152 000	9 800	15 500	2 800	4 000
127.000		36.512	36.170	28.575	3.5	0.8	166 000	234 000	16 900	23 900	2 800	3 800
130.175		41.275	41.275	31.750	3.5	3.3	195 000	263 000	19 800	26 800	2 800	3 800
146.050		41.275	39.688	25.400	3.5	3.3	193 000	225 000	19 700	22 900	2 400	3 400
146.050		41.275	41.275	31.750	3.5	3.3	207 000	296 000	21 100	30 000	2 400	3 200
149.225		53.975	54.229	44.450	5.0	3.3	287 000	410 000	29 300	41 500	2 600	3 400
150.089		44.450	46.672	36.512	3.5	3.3	265 000	370 000	27 000	37 500	2 400	3 200

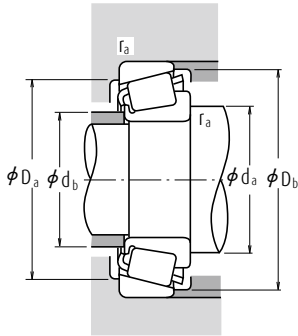

**Dynamic Equivalent Load**  $P = X F_r + Y F_a$

$F_a/F_r \leq e$		$F_a/F_r > e$	
X	Y	X	Y
1	0	0.4	$Y_1$

**Static Equivalent Load**

$P_0 = 0.5 F_r + Y_0 F_a$   
 When  $F_r > 0.5 F_r + Y_0 F_a$ , use  $P_0 = F_r$

The values of  $e$ ,  $Y_1$  and  $Y_0$  are given in the table below.

Bearing Numbers		Abutment and Fillet Dimensions (mm)					Eff. Load Centers (mm)	Constant	Axial Load Factors		Mass (kg)		
CONE	CUP	$d_a$	$d_b$	$D_a$	$D_b$	$r_a$ max.			a	e	$Y_1$	$Y_0$	CONE
▲ JLM 710949	▲ JLM 710910	77	71	96	101	3	1	23.7	0.45	1.3	0.73	0.526	0.237
▲ JM 511946	▲ JM 511910	78	72	99	105	3	2.5	24.5	0.40	1.5	0.82	0.72	0.342
478	472 A	77	73	106	114	2.3	3.3	24.3	0.38	1.6	0.86	0.942	0.466
▲ JH 211749	▲ JH 211710	80	74	107	114	3	2.5	27.9	0.34	1.8	0.98	1.25	0.625
6379	6320	84	77	117	126	3.5	3.3	35.0	0.32	1.8	1.0	2.25	1.39
H 715340	H 715311	88	82	118	132	3.5	3.3	37.1	0.47	1.3	0.70	2.4	0.961
395 A	394 A	73	73	101	104	0.8	1.3	20.9	0.40	1.5	0.82	0.528	0.263
395 S	394 A	79	73	101	104	3.5	1.3	20.9	0.40	1.5	0.82	0.524	0.263
3984	3920	80	74	99	106	3.5	3.2	25.5	0.40	1.5	0.82	0.712	0.454
3994	3920	84	74	99	106	5.5	3.2	25.5	0.40	1.5	0.82	0.706	0.454
39590	39521	80	74	103	107	3.5	0.8	23.5	0.34	1.8	0.97	0.822	0.365
39590	39520	80	74	101	107	3.5	3.3	23.5	0.34	1.8	0.97	0.822	0.359
33262	33462	81	75	104	112	3.5	3.3	26.8	0.44	1.4	0.76	0.911	0.442
560	553 X	81	75	108	115	3.5	3.3	28.8	0.35	1.7	0.95	1.14	0.692
HM 212049	HM 212010	82	75	110	116	3.5	1.5	26.9	0.34	1.8	0.98	1.25	0.604
HM 212049	HM 212011	81	74	108	116	3.5	3.3	26.9	0.34	1.8	0.98	1.25	0.598
560	552 A	81	75	109	116	3.5	3.3	28.8	0.35	1.7	0.95	1.14	0.764
H 715341	H 715311	89	83	118	132	3.5	3.3	37.1	0.47	1.3	0.70	2.34	0.961
399 A	394 A	78	74	101	104	2.3	1.3	20.9	0.40	1.5	0.82	0.497	0.263
480	472	83	76	106	113	3.5	2	25.1	0.38	1.6	0.86	0.862	0.493
560 S	553 X	83	76	108	115	3.5	3.3	28.8	0.35	1.7	0.95	1.09	0.692
570	563	83	77	112	120	3.5	3.3	28.3	0.36	1.6	0.91	1.32	0.655
H 414245	H 414210	86	82	121	129	3.5	3.3	30.6	0.36	1.7	0.92	1.95	0.796
H 715343	H 715311	90	84	118	132	3.5	3.3	37.1	0.47	1.3	0.70	2.28	0.961
9185	9121	94	81	130	145	3.5	3.3	44.3	0.66	0.92	0.50	2.53	1.21
LM 613449	LM 613410	78	76	104	107	1.5	0.8	22.1	0.42	1.4	0.79	0.562	0.238
29675	29620	80	77	101	109	1.5	3.3	26.3	0.49	1.2	0.68	0.695	0.273
33275	33462	84	77	104	112	3.5	3.3	26.8	0.44	1.4	0.76	0.83	0.442
47487	47420	84	78	107	114	3.5	3.3	26.0	0.36	1.7	0.92	1.02	0.477
29675	29630	79	78	105	113	1.5	3.3	26.3	0.49	1.2	0.68	0.695	0.489
566	563 X	85	78	114	120	3.5	0.8	28.3	0.36	1.6	0.91	1.27	0.658
643	633	86	80	116	124	3.5	3.3	29.9	0.36	1.7	0.91	1.56	0.712
H 913849	H 913810	95	82	124	138	3.5	3.3	44.4	0.78	0.77	0.42	1.95	0.898
655	653	88	82	131	139	3.5	3.3	33.2	0.41	1.5	0.81	2.35	0.891
6454	6420	94	85	129	140	5	3.3	39.0	0.36	1.7	0.91	2.95	1.63
745 A	742	88	82	134	142	3.5	3.3	32.5	0.33	1.8	1.0	2.82	1.07

**Note** ▲ The tolerances are listed in Tables 2, 3 and 4 on Pages B139 and B140.



# Single-Row Tapered Roller Bearings (Inch Design)

Bore Diameter 70.000 - 76.200 mm

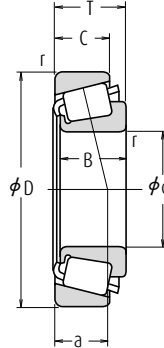

Boundary Dimensions (mm)							Basic Load Ratings (N) {kgf}				Limiting Speeds (min <sup>-1</sup> )	
d	D	T	B	C	Cone	Cup	C <sub>r</sub>	C <sub>0r</sub>	C <sub>r</sub>	C <sub>0r</sub>	Grease	Oil
					r	r						
					min.							
70.000	110.000	26.000	25.000	20.500	1.0	2.5	98 500	152 000	10 000	15 500	3 000	4 000
	115.000	29.000	29.000	23.000	3.0	2.5	126 000	177 000	12 900	18 100	3 000	4 000
	120.000	29.795	29.007	24.237	2.0	2.0	123 000	169 000	12 500	17 200	3 000	4 000
71.438	117.475	30.162	30.162	23.812	3.5	3.3	119 000	179 000	12 200	18 300	3 000	4 000
	120.000	32.545	32.545	26.195	3.5	3.3	152 000	225 000	15 500	22 900	3 000	4 000
	127.000	36.512	36.170	28.575	6.4	3.3	166 000	234 000	16 900	23 900	2 800	3 800
	127.000	36.512	36.170	28.575	3.5	3.3	166 000	234 000	16 900	23 900	2 800	3 800
	130.175	41.275	41.275	31.750	6.4	3.3	195 000	263 000	19 800	26 800	2 800	3 800
	136.525	41.275	41.275	31.750	3.5	3.3	195 000	263 000	19 800	26 800	2 800	3 800
73.025	136.525	41.275	41.275	31.750	3.5	3.3	229 000	297 000	23 300	30 500	2 600	3 600
	136.525	46.038	46.038	36.512	3.5	3.3	233 000	370 000	23 800	37 500	2 600	3 400
	112.712	25.400	25.400	19.050	3.5	3.3	96 000	152 000	9 800	15 500	2 800	4 000
	117.475	30.162	30.162	23.812	3.5	3.3	119 000	179 000	12 200	18 300	3 000	4 000
	127.000	36.512	36.170	28.575	3.5	3.3	166 000	234 000	16 900	23 900	2 800	3 800
	146.050	41.275	41.275	31.750	3.5	3.3	207 000	296 000	21 100	30 000	2 400	3 200
73.817	149.225	53.975	54.229	44.450	3.5	3.3	287 000	410 000	29 300	41 500	2 600	3 400
	127.000	36.512	36.170	28.575	0.8	3.3	166 000	234 000	16 900	23 900	2 800	3 800
74.612	150.000	41.275	41.275	31.750	3.5	3.0	207 000	296 000	21 100	30 000	2 400	3 200
75.000	115.000	25.000	25.000	19.000	3.0	2.5	101 000	150 000	10 300	15 300	3 000	4 000
	120.000	31.000	29.500	25.000	3.0	2.5	129 000	198 000	13 100	20 200	2 800	3 800
	145.000	51.000	51.000	42.000	3.0	2.5	283 000	410 000	28 900	41 500	2 600	3 400
76.200	121.442	24.608	23.012	17.462	2.0	2.0	89 000	124 000	9 100	12 600	2 800	3 800
	127.000	30.162	31.000	22.225	3.5	3.3	134 000	195 000	13 700	19 900	2 800	3 800
	127.000	30.162	31.001	22.225	6.4	3.3	134 000	195 000	13 700	19 900	2 800	3 800
	133.350	33.338	33.338	26.195	0.8	3.3	154 000	237 000	15 700	24 200	2 600	3 600
	135.733	44.450	46.101	34.925	3.5	3.3	216 000	340 000	22 000	35 000	2 600	3 600
	136.525	30.162	29.769	22.225	3.5	3.3	130 000	192 000	13 300	19 600	2 600	3 400
	136.525	30.162	29.769	22.225	6.4	3.3	130 000	192 000	13 300	19 600	2 600	3 400
	139.992	36.512	36.098	28.575	3.5	3.3	175 000	260 000	17 800	26 500	2 600	3 400
	149.225	53.975	54.229	44.450	3.5	3.3	287 000	410 000	29 300	41 500	2 600	3 400
	152.400	39.688	36.322	30.162	3.5	3.2	183 000	285 000	18 700	29 100	2 200	3 200
	152.400	41.275	41.275	31.750	3.5	3.3	207 000	296 000	21 100	30 000	2 400	3 200
	161.925	49.212	46.038	31.750	3.5	3.3	248 000	290 000	25 300	29 600	2 200	3 000
	161.925	53.975	55.100	42.862	3.5	3.3	325 000	480 000	33 000	49 000	2 200	3 000
	161.925	53.975	55.100	42.862	6.4	3.3	325 000	480 000	33 000	49 000	2 200	3 000
	161.925	53.975	55.100	42.862	6.4	0.8	325 000	480 000	33 000	49 000	2 200	3 000

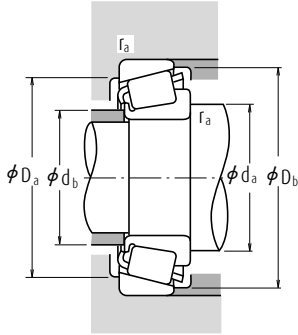

**Dynamic Equivalent Load**  $P = X F_r + Y F_a$

$F_a/F_r \leq e$		$F_a/F_r > e$	
X	Y	X	Y
1	0	0.4	$Y_1$

**Static Equivalent Load**

$P_0 = 0.5 F_r + Y_0 F_a$   
 When  $F_r > 0.5 F_r + Y_0 F_a$ , use  $P_0 = F_r$

The values of  $e$ ,  $Y_1$  and  $Y_0$  are given in the table below.

Bearing Numbers		Abutment and Fillet Dimensions (mm)					Eff. Load Centers (mm)	Constant	Axial Load Factors		Mass (kg)		
CONE	CUP	$d_a$	$d_b$	$D_a$	$D_b$	Cone Cup $r_a$ max.			a	e	$Y_1$	$Y_0$	CONE
▲ JLM 813049	▲ JLM 813010	78	77	98	105	1	2.5	26.2	0.49	1.2	0.68	0.604	0.304
▲ JM 612949	▲ JM 612910	83	77	103	110	3	2.5	26.4	0.43	1.4	0.77	0.800	0.362
484	472	80	78	106	113	2	2	25.1	0.38	1.6	0.86	0.822	0.493
33281	33462	85	79	104	112	3.5	3.3	26.8	0.44	1.4	0.76	0.789	0.442
47490	47420	86	79	107	114	3.5	3.3	26.0	0.36	1.7	0.92	0.983	0.477
567 S	563	92	80	112	120	6.4	3.3	28.3	0.36	1.6	0.91	1.21	0.655
567 A	563	86	80	112	120	3.5	3.3	28.3	0.36	1.6	0.91	1.23	0.655
645	633	93	81	116	124	6.4	3.3	29.9	0.36	1.7	0.91	1.49	0.712
644	632	87	81	118	125	3.5	3.3	29.9	0.36	1.7	0.91	1.5	1.04
H 414249	H 414210	89	83	121	129	3.5	3.3	30.6	0.36	1.7	0.92	1.83	0.796
H 715345	H 715311	92	84	119	132	3.5	3.3	37.1	0.47	1.3	0.70	2.15	0.961
29685	29620	86	80	101	109	3.5	3.3	26.3	0.49	1.2	0.68	0.62	0.273
33287	33462	87	80	104	112	3.5	3.3	26.8	0.44	1.4	0.76	0.746	0.442
567	563	88	81	112	120	3.5	3.3	28.3	0.36	1.6	0.91	1.17	0.655
657	653	91	85	131	139	3.5	3.3	33.2	0.41	1.5	0.81	2.24	0.891
6460	6420	93	87	129	140	3.5	3.3	39.0	0.36	1.7	0.91	2.8	1.63
568	563	83	82	112	120	0.8	3.3	28.3	0.36	1.6	0.91	1.15	0.655
658	653 X	92	86	133	141	3.5	3	33.2	0.41	1.5	0.81	2.37	0.932
▲ JLM 714149	▲ JLM 714110	87	81	104	110	3	2.5	25.3	0.46	1.3	0.72	0.638	0.272
▲ JM 714249	▲ JM 714210	88	83	108	115	3	2.5	28.8	0.44	1.4	0.74	0.863	0.436
▲ JH 415647	▲ JH 415610	94	89	129	139	3	2.5	36.7	0.36	1.7	0.91	2.64	1.19
34300	34478	86	84	111	116	2	2	26.3	0.45	1.3	0.73	0.65	0.316
42687	42620	90	84	114	121	3.5	3.3	27.3	0.42	1.4	0.79	1.03	0.438
42688	42620	94	84	114	121	6.4	3.3	27.3	0.42	1.4	0.79	1.01	0.438
47680	47620	86	85	119	128	0.8	3.3	29.0	0.40	1.5	0.82	1.39	0.577
5760	5735	94	88	119	130	3.5	3.3	32.9	0.41	1.5	0.81	1.86	0.887
495 A	493	92	86	122	130	3.5	3.3	28.7	0.44	1.4	0.74	1.27	0.55
495 AX	493	98	86	122	130	6.4	3.3	28.7	0.44	1.4	0.74	1.26	0.55
575	572	92	86	125	133	3.5	3.3	31.1	0.40	1.5	0.82	1.61	0.788
6461	6420	96	89	129	140	3.5	3.3	39.0	0.36	1.7	0.91	2.64	1.63
590 A	592 A	95	89	135	145	3.5	3.2	37.1	0.44	1.4	0.75	2.2	1.06
659	652	93	87	134	141	3.5	3.3	33.2	0.41	1.5	0.81	2.11	1.26
9285	9220	103	90	138	153	3.5	3.3	49.8	0.71	0.85	0.47	2.82	1.4
6576	6535	99	92	141	154	3.5	3.3	40.7	0.40	1.5	0.82	3.74	1.67
6575	6535	104	92	141	154	6.4	3.3	40.7	0.40	1.5	0.82	3.73	1.67
6575	6536	104	92	144	154	6.4	0.8	40.7	0.40	1.5	0.82	3.73	1.68

**Note** ▲ The tolerances are listed in Tables 2, 3 and 4 on Pages B139 and B140.

# Single-Row Tapered Roller Bearings (Inch Design)

Bore Diameter 76.200 – 83.345 mm

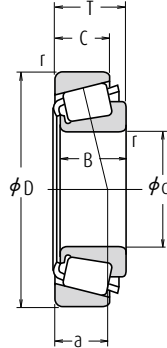

Boundary Dimensions (mm)							Basic Load Ratings (N) {kgf}				Limiting Speeds (min <sup>-1</sup> )	
d	D	T	B	C	Cone	Cup	C <sub>r</sub>	C <sub>or</sub>	C <sub>r</sub>	C <sub>or</sub>	Grease	Oil
					r min.	r min.						
<b>76.200</b>	168.275	53.975	56.363	41.275	6.4	3.3	345 000	470 000	35 000	48 000	2 200	3 000
	168.275	53.975	56.363	41.275	0.8	3.3	345 000	470 000	35 000	48 000	2 200	3 000
	171.450	49.212	46.038	31.750	3.5	3.3	257 000	310 000	26 200	32 000	2 000	2 800
	177.800	55.562	50.800	34.925	3.5	3.3	257 000	310 000	26 200	32 000	2 000	2 800
<b>77.788</b>	121.442	24.608	23.012	17.462	3.5	2.0	89 000	124 000	9 100	12 600	2 800	3 800
	127.000	30.162	31.000	22.225	3.5	3.3	134 000	195 000	13 700	19 900	2 800	3 800
	135.733	44.450	46.101	34.925	3.5	3.3	216 000	340 000	22 000	35 000	2 600	3 600
<b>79.375</b>	146.050	41.275	41.275	31.750	3.5	3.3	207 000	296 000	21 100	30 000	2 400	3 200
	150.089	44.450	46.672	36.512	3.5	3.3	265 000	370 000	27 000	37 500	2 400	3 200
<b>80.000</b>	130.000	35.000	34.000	28.500	3.0	2.5	166 000	251 000	17 000	25 600	2 600	3 600
<b>80.962</b>	136.525	30.162	29.769	22.225	3.5	3.3	130 000	192 000	13 300	19 600	2 600	3 400
	139.700	36.512	36.098	28.575	3.5	3.3	175 000	260 000	17 800	26 500	2 600	3 400
	139.992	36.512	36.098	28.575	3.5	3.3	175 000	260 000	17 800	26 500	2 600	3 400
<b>82.550</b>	125.412	25.400	25.400	19.845	3.5	1.5	102 000	164 000	10 400	16 700	2 600	3 600
	133.350	30.162	29.769	22.225	3.5	3.3	130 000	192 000	13 300	19 600	2 600	3 400
	133.350	33.338	33.338	26.195	3.5	3.3	154 000	237 000	15 700	24 200	2 600	3 600
	133.350	33.338	33.338	26.195	0.8	3.3	154 000	237 000	15 700	24 200	2 600	3 600
	133.350	33.338	33.338	26.195	6.8	3.3	154 000	237 000	15 700	24 200	2 600	3 600
	133.350	39.688	39.688	32.545	6.8	3.3	179 000	310 000	18 300	31 500	2 600	3 600
	136.525	30.162	29.769	22.225	3.5	3.3	130 000	192 000	13 300	19 600	2 600	3 400
	139.700	36.512	36.098	28.575	3.5	3.3	175 000	260 000	17 800	26 500	2 600	3 400
	139.992	36.512	36.098	28.575	3.5	3.3	175 000	260 000	17 800	26 500	2 600	3 400
	139.992	36.512	36.098	28.575	6.8	3.3	175 000	260 000	17 800	26 500	2 600	3 400
	146.050	41.275	41.275	31.750	3.5	3.3	207 000	296 000	21 100	30 000	2 400	3 200
	150.000	44.455	46.672	35.000	3.5	3.3	265 000	370 000	27 000	37 500	2 400	3 200
150.089	44.450	46.672	36.512	3.5	3.3	265 000	370 000	27 000	37 500	2 400	3 200	
152.400	41.275	41.275	31.750	3.5	3.3	207 000	296 000	21 100	30 000	2 400	3 200	
161.925	47.625	48.260	38.100	3.5	3.3	274 000	390 000	28 000	40 000	2 200	3 000	
161.925	53.975	55.100	42.862	3.5	3.3	325 000	480 000	33 000	49 000	2 200	3 000	
168.275	47.625	48.260	38.100	3.5	3.3	274 000	390 000	28 000	40 000	2 200	3 000	
168.275	53.975	56.363	41.275	3.5	3.3	345 000	470 000	35 000	48 000	2 200	3 000	
<b>83.345</b>	125.412	25.400	25.400	19.845	3.5	1.5	102 000	164 000	10 400	16 700	2 600	3 600
	125.412	25.400	25.400	19.845	0.8	1.5	102 000	164 000	10 400	16 700	2 600	3 600

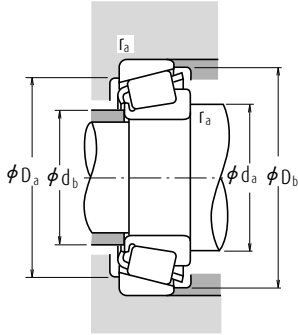

**Dynamic Equivalent Load**  $P = X F_r + Y F_a$

$F_a/F_r \leq e$		$F_a/F_r > e$	
X	Y	X	Y
1	0	0.4	$Y_1$

**Static Equivalent Load**

$P_0 = 0.5 F_r + Y_0 F_a$   
 When  $F_r > 0.5 F_r + Y_0 F_a$ , use  $P_0 = F_r$

The values of  $e$ ,  $Y_1$  and  $Y_0$  are given in the table below.

Bearing Numbers		Abutment and Fillet Dimensions (mm)						Eff. Load Centers (mm)	Constant	Axial Load Factors		Mass (kg)	
CONE	CUP	$d_a$	$d_b$	$D_a$	$D_b$	Cone $r_a$ max.	Cup			$a$	$e$	$Y_1$	$Y_0$
843	832	101	89	149	155	6.4	3.3	35.2	0.30	2.0	1.1	4.11	1.74
837	832	90	89	149	155	0.8	3.3	35.2	0.30	2.0	1.1	4.13	1.74
9380	9321	105	98	147	164	3.5	3.3	54.1	0.76	0.79	0.43	3.47	1.51
9378	9320	105	98	148	164	3.5	3.3	57.3	0.76	0.79	0.43	3.71	2.24
34306	34478	90	84	110	116	3.5	2	26.3	0.45	1.3	0.73	0.612	0.316
42690	42620	91	85	114	121	3.5	3.3	27.3	0.42	1.4	0.79	0.976	0.438
5795	5735	96	89	119	130	3.5	3.3	32.9	0.41	1.5	0.81	1.79	0.887
661	653	96	90	131	139	3.5	3.3	33.2	0.41	1.5	0.81	1.99	0.891
750	742	96	90	134	142	3.5	3.3	32.5	0.33	1.8	1.0	2.42	1.07
▲ JM 515649	▲ JM 515610	94	88	117	125	3	2.5	29.9	0.39	1.5	0.85	1.18	0.583
496	493	95	89	122	130	3.5	3.3	28.7	0.44	1.4	0.74	1.13	0.55
581	572 X	96	90	125	133	3.5	3.3	31.1	0.40	1.5	0.82	1.44	0.774
581	572	96	90	125	133	3.5	3.3	31.1	0.40	1.5	0.82	1.44	0.788
27687	27620	96	89	115	120	3.5	1.5	25.7	0.42	1.4	0.79	0.747	0.348
495	492 A	97	90	120	128	3.5	3.3	28.7	0.44	1.4	0.74	1.08	0.434
47686	47620	97	90	119	128	3.5	3.3	29.0	0.40	1.5	0.82	1.18	0.577
47685	47620	90	90	119	128	0.8	3.3	29.0	0.40	1.5	0.82	1.18	0.577
47687	47620	103	90	119	128	6.8	3.3	29.0	0.40	1.5	0.82	1.16	0.577
HM 516448	HM 516410	105	92	118	128	6.8	3.3	32.4	0.40	1.5	0.82	1.35	0.767
495	493	97	90	122	130	3.5	3.3	28.7	0.44	1.4	0.74	1.08	0.55
580	572 X	98	91	125	133	3.5	3.3	31.1	0.40	1.5	0.82	1.39	0.774
580	572	98	91	125	133	3.5	3.3	31.1	0.40	1.5	0.82	1.39	0.788
582	572	104	91	125	133	6.8	3.3	31.1	0.40	1.5	0.82	1.37	0.788
663	653	99	92	131	139	3.5	3.3	33.2	0.41	1.5	0.81	1.85	0.891
749 A	743	99	93	134	142	3.5	3.3	32.5	0.33	1.8	1.0	2.26	1.04
749 A	742	98	93	135	143	3.5	3.3	32.5	0.33	1.8	1.0	2.26	1.07
663	652	99	92	134	141	3.5	3.3	33.2	0.41	1.5	0.81	1.85	1.26
757	752	100	94	144	150	3.5	3.3	35.6	0.34	1.8	0.97	2.79	1.61
6559	6535	104	98	141	154	3.5	3.3	40.7	0.40	1.5	0.82	3.4	1.67
757	753	100	94	147	150	3.5	3.3	35.6	0.34	1.8	0.97	2.79	2.1
842	832	101	94	149	155	3.5	3.3	35.2	0.30	2.0	1.1	3.76	1.74
27690	27620	96	90	115	120	3.5	1.5	25.7	0.42	1.4	0.79	0.727	0.348
27689	27620	90	90	115	120	0.8	1.5	25.7	0.42	1.4	0.79	0.732	0.348

**Note** ▲ The tolerances are listed in Tables 2, 3 and 4 on Pages B139 and B140.

# Single-Row Tapered Roller Bearings (Inch Design)

Bore Diameter 84.138 – 90.488 mm

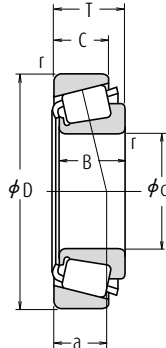

d	Boundary Dimensions (mm)					Cone		Basic Load Ratings (N)		Limiting Speeds (min <sup>-1</sup> )		
	D	T	B	C	r min.	Cup	C <sub>r</sub>	C <sub>0r</sub>	C <sub>r</sub>	C <sub>0r</sub>	Grease	Oil
<b>84.138</b>	136.525	30.162	29.769	22.225	3.5	3.3	130 000	192 000	13 300	19 600	2 600	3 400
	146.050	41.275	41.275	31.750	3.5	3.3	207 000	296 000	21 100	30 000	2 400	3 200
<b>85.000</b>	171.450	49.212	46.038	31.750	3.5	3.3	257 000	310 000	26 200	32 000	2 000	2 800
	130.000	30.000	29.000	24.000	6.0	2.5	138 000	222 000	14 100	22 700	2 600	3 600
<b>85.026</b>	130.000	30.000	29.000	24.000	3.0	2.5	138 000	222 000	14 100	22 700	2 600	3 600
	140.000	39.000	38.000	31.500	3.0	2.5	202 000	305 000	20 600	31 000	2 400	3 400
<b>85.725</b>	150.000	46.000	46.000	38.000	3.0	2.5	275 000	390 000	28 000	40 000	2 400	3 200
	150.089	44.450	46.672	36.512	3.5	3.3	265 000	370 000	27 000	37 500	2 400	3 200
<b>87.312</b>	150.089	44.450	46.672	36.512	5.0	3.3	265 000	370 000	27 000	37 500	2 400	3 200
	133.350	30.162	29.769	22.225	3.5	3.3	130 000	192 000	13 300	19 600	2 600	3 400
<b>88.900</b>	136.525	30.162	29.769	22.225	3.5	3.3	130 000	192 000	13 300	19 600	2 600	3 400
	142.138	42.862	42.862	34.133	4.8	3.3	221 000	360 000	22 500	36 500	2 400	3 400
<b>88.900</b>	146.050	41.275	41.275	31.750	6.4	3.3	207 000	296 000	21 100	30 000	2 400	3 200
	146.050	41.275	41.275	31.750	3.5	3.3	207 000	296 000	21 100	30 000	2 400	3 200
<b>87.312</b>	152.400	39.688	36.322	30.162	3.5	3.2	183 000	285 000	18 700	29 100	2 200	3 200
	161.925	47.625	48.260	38.100	3.5	3.3	274 000	390 000	28 000	40 000	2 200	3 000
<b>87.312</b>	168.275	41.275	41.275	30.162	3.5	3.3	223 000	345 000	22 700	35 000	2 000	2 800
	190.500	57.150	57.531	46.038	8.0	3.3	390 000	520 000	39 500	53 500	1 900	2 600
<b>88.900</b>	149.225	31.750	28.971	24.608	3.0	3.3	140 000	218 000	14 300	22 300	2 200	3 000
	152.400	39.688	36.322	30.162	3.5	3.2	183 000	285 000	18 700	29 100	2 200	3 200
<b>88.900</b>	152.400	39.688	39.688	30.162	6.4	3.3	253 000	365 000	25 800	37 500	2 200	3 200
	161.925	47.625	48.260	38.100	3.5	3.3	274 000	390 000	28 000	40 000	2 200	3 000
<b>88.900</b>	161.925	47.625	48.260	38.100	7.0	3.3	274 000	390 000	28 000	40 000	2 200	3 000
	161.925	53.975	55.100	42.862	3.5	3.3	325 000	480 000	33 000	49 000	2 200	3 000
<b>88.900</b>	168.275	47.625	48.260	38.100	3.5	3.3	274 000	390 000	28 000	40 000	2 200	3 000
	168.275	53.975	56.363	41.275	3.5	3.3	345 000	470 000	35 000	48 000	2 200	3 000
<b>88.900</b>	190.500	57.150	57.531	44.450	8.0	3.3	355 000	500 000	36 000	51 000	1 900	2 600
	190.500	57.150	57.531	46.038	8.0	3.3	390 000	520 000	39 500	53 500	1 900	2 600
<b>90.000</b>	145.000	35.000	34.000	27.000	3.0	2.5	190 000	285 000	19 400	29 000	2 400	3 200
	147.000	40.000	40.000	32.500	7.0	3.5	229 000	345 000	23 400	35 000	2 400	3 200
<b>90.488</b>	155.000	44.000	44.000	35.500	3.0	2.5	274 000	395 000	28 000	40 000	2 200	3 000
	161.925	47.625	48.260	38.100	3.5	3.3	274 000	390 000	28 000	40 000	2 200	3 000

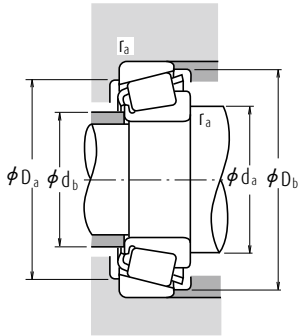

**Dynamic Equivalent Load**  $P = X F_r + Y F_a$

$F_a/F_r \leq e$		$F_a/F_r > e$	
X	Y	X	Y
1	0	0.4	$Y_1$

**Static Equivalent Load**

$P_0 = 0.5 F_r + Y_0 F_a$   
 When  $F_r > 0.5 F_r + Y_0 F_a$ , use  $P_0 = F_r$

The values of  $e$ ,  $Y_1$  and  $Y_0$  are given in the table below.

Bearing Numbers		Abutment and Fillet Dimensions (mm)					Eff. Load Centers (mm)	Constant	Axial Load Factors		Mass (kg)		
CONE	CUP	$d_a$	$d_b$	$D_a$	$D_b$	Cone Cup $r_a$ max.			a	e	$Y_1$	$Y_0$	CONE
498	493	98	91	122	130	3.5	3.3	28.7	0.44	1.4	0.74	1.04	0.55
664	653	99	93	131	139	3.5	3.3	33.2	0.41	1.5	0.81	1.79	0.891
9385	9321	111	98	147	164	3.5	3.3	54.1	0.76	0.79	0.43	3.11	1.51
▲ JM 716648	▲ JM 716610	104	92	117	125	6	2.5	29.5	0.44	1.4	0.74	0.931	0.461
▲ JM 716649	▲ JM 716610	98	92	117	125	3	2.5	29.5	0.44	1.4	0.74	0.943	0.461
▲ JHM 516849	▲ JHM 516810	100	94	125	134	3	2.5	33.3	0.41	1.5	0.81	1.55	0.768
▲ JH 217249	▲ JH 217210	101	95	134	142	3	2.5	33.9	0.33	1.8	0.99	2.29	1.09
749	742	101	95	134	142	3.5	3.3	32.5	0.33	1.8	1.0	2.14	1.07
749 S	742	104	95	134	142	5	3.3	32.5	0.33	1.8	1.0	2.14	1.07
497	492 A	99	93	120	128	3.5	3.3	28.7	0.44	1.4	0.74	0.987	0.434
497	493	99	93	122	130	3.5	3.3	28.7	0.44	1.4	0.74	0.987	0.55
HM 617049	HM 617010	106	95	125	137	4.8	3.3	35.4	0.43	1.4	0.76	1.77	0.911
665 A	653	107	95	131	139	6.4	3.3	33.2	0.41	1.5	0.81	1.71	0.891
665	653	102	95	131	139	3.5	3.3	33.2	0.41	1.5	0.81	1.72	0.891
596	592 A	102	96	135	144	3.5	3.2	37.1	0.44	1.4	0.75	1.85	1.06
758	752	103	97	144	150	3.5	3.3	35.6	0.34	1.8	0.97	2.63	1.61
677	672	105	99	149	160	3.5	3.3	38.3	0.47	1.3	0.70	2.91	1.24
HH 221432	HH 221410	118	103	171	179	8	3.3	42.3	0.33	1.8	0.99	5.51	2.24
42350	42587	104	98	134	143	3	3.3	34.9	0.49	1.2	0.67	1.39	0.711
593	592 A	104	98	135	144	3.5	3.2	37.1	0.44	1.4	0.75	1.73	1.06
HM 518445	HM 518410	107	96	137	148	6.4	3.3	33.1	0.40	1.5	0.82	2.11	0.776
759	752	106	99	144	150	3.5	3.3	35.6	0.34	1.8	0.97	2.47	1.61
766	752	113	99	144	150	7	3.3	35.6	0.34	1.8	0.97	2.45	1.61
6580	6535	109	102	141	154	3.5	3.3	40.7	0.40	1.5	0.82	3.03	1.67
759	753	106	99	147	150	3.5	3.3	35.6	0.34	1.8	0.97	2.47	2.1
850	832	106	100	149	155	3.5	3.3	35.2	0.30	2.0	1.1	3.39	1.74
855	854	118	103	170	174	8	3.3	41.8	0.33	1.8	0.99	4.99	2.55
HH 221434	HH 221410	120	105	171	179	8	3.3	42.3	0.33	1.8	0.99	5.41	2.24
▲ JM 718149	▲ JM 718110	105	99	131	139	3	2.5	33.0	0.44	1.4	0.74	1.49	0.66
*HM 218248	**HM 218210	111	98	133	141	7	3.5	30.8	0.33	1.8	0.99	1.77	0.796
▲ JHM 318448	▲ JHM 318410	106	100	140	148	3	2.5	34.1	0.34	1.7	0.96	2.32	1.01
760	752	107	101	144	150	3.5	3.3	35.6	0.34	1.8	0.97	2.38	1.61

- Notes**
- \* The maximum bore diameter is listed and its tolerance is negative (See Table 8.4.1 on Page A70).
  - \*\* The maximum outside diameter is listed and its tolerance is negative (See Table 8.4.2 on Pages A70 and A71).
  - ▲ The tolerances are listed in Tables 2, 3 and 4 on Pages B139 and B140.

# Single-Row Tapered Roller Bearings (Inch Design)

Bore Diameter 92.075 – 100.012 mm

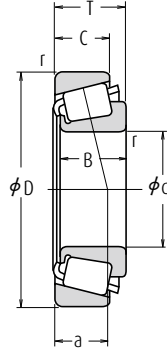

d	Boundary Dimensions (mm)					Cone		Basic Load Ratings (N)		Basic Load Ratings {kgf}		Limiting Speeds (min <sup>-1</sup> )	
	D	T	B	C	r min.	Cup	C <sub>r</sub>	C <sub>0r</sub>	C <sub>r</sub>	C <sub>0r</sub>	Grease	Oil	
92.075	146.050	33.338	34.925	26.195	3.5	3.3	169 000	280 000	17 300	28 500	2 400	3 200	
	148.430	28.575	28.971	21.433	3.5	3.0	140 000	218 000	14 300	22 300	2 200	3 000	
	152.400	39.688	36.322	30.162	3.5	3.2	183 000	285 000	18 700	29 100	2 200	3 200	
	152.400	39.688	36.322	30.162	6.4	3.2	183 000	285 000	18 700	29 100	2 200	3 200	
93.662	168.275	41.275	41.275	30.162	3.5	3.3	223 000	345 000	22 700	35 000	2 000	2 800	
	190.500	57.150	57.531	44.450	8.0	3.3	355 000	500 000	36 000	51 000	1 900	2 600	
	148.430	28.575	28.971	21.433	3.0	3.0	140 000	218 000	14 300	22 300	2 200	3 000	
	149.225	31.750	28.971	24.608	3.0	3.3	140 000	218 000	14 300	22 300	2 200	3 000	
95.000	152.400	39.688	36.322	30.162	3.5	3.2	183 000	285 000	18 700	29 100	2 200	3 200	
	150.000	35.000	34.000	27.000	3.0	2.5	183 000	285 000	18 700	29 100	2 200	3 200	
	148.430	28.575	28.971	21.433	3.0	3.0	140 000	218 000	14 300	22 300	2 200	3 000	
	149.225	31.750	28.971	24.608	3.5	3.3	140 000	218 000	14 300	22 300	2 200	3 000	
95.250	152.400	39.688	36.322	30.162	3.5	3.2	183 000	285 000	18 700	29 100	2 200	3 200	
	168.275	41.275	41.275	30.162	3.5	3.3	223 000	345 000	22 700	35 000	2 000	2 800	
	171.450	47.625	48.260	38.100	3.5	3.3	282 000	415 000	28 800	42 500	2 000	2 800	
	180.975	47.625	48.006	38.100	3.5	3.3	258 000	375 000	26 300	38 500	2 000	2 600	
	190.500	57.150	57.531	44.450	8.0	3.3	355 000	500 000	36 000	51 000	1 900	2 600	
	190.500	57.150	57.531	46.038	8.0	3.3	390 000	520 000	39 500	53 500	1 900	2 600	
	148.430	28.575	28.971	21.433	3.5	3.0	140 000	218 000	14 300	22 300	2 200	3 000	
	149.225	31.750	28.971	24.606	3.5	3.3	140 000	218 000	14 300	22 300	2 200	3 000	
98.425	161.925	36.512	36.116	26.195	3.5	3.3	191 000	310 000	19 500	31 500	2 000	2 800	
	168.275	41.275	41.275	30.162	3.5	3.3	223 000	345 000	22 700	35 000	2 000	2 800	
	180.975	47.625	48.006	38.100	3.5	3.3	258 000	375 000	26 300	38 500	2 000	2 600	
	190.500	57.150	57.531	44.450	3.5	3.3	355 000	500 000	36 000	51 000	1 900	2 600	
99.982	190.500	57.150	57.531	46.038	3.5	3.3	390 000	520 000	39 500	53 500	1 900	2 600	
	190.500	57.150	57.531	46.038	6.4	3.3	390 000	520 000	39 500	53 500	1 900	2 600	
	100.000	150.000	32.000	30.000	26.000	2.3	2.3	146 000	235 000	14 900	24 000	2 200	3 000
	155.000	36.000	35.000	28.000	3.0	2.5	191 000	325 000	19 500	33 000	2 000	2 800	
100.012	160.000	41.000	40.000	32.000	3.0	2.5	239 000	380 000	24 400	38 500	2 000	2 800	
	157.162	36.512	36.116	26.195	3.5	3.3	191 000	310 000	19 500	31 500	2 000	2 800	

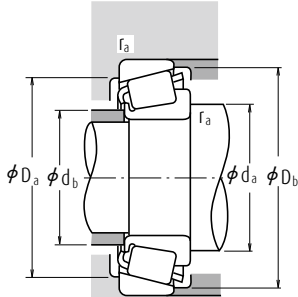

### Dynamic Equivalent Load $P = X F_r + Y F_a$

$F_a/F_r \leq e$		$F_a/F_r > e$	
X	Y	X	Y
1	0	0.4	$Y_1$

### Static Equivalent Load

$P_0 = 0.5 F_r + Y_0 F_a$   
 When  $F_r > 0.5 F_r + Y_0 F_a$ , use  $P_0 = F_r$

The values of  $e$ ,  $Y_1$  and  $Y_0$  are given in the table below.

Bearing Numbers		Abutment and Fillet Dimensions (mm)					Cone	Cup	Eff. Load Centers (mm)	Constant	Axial Load Factors		Mass (kg)	
CONE	CUP	$d_a$	$d_b$	$D_a$	$D_b$	$r_a$ max.					a	e	$Y_1$	$Y_0$
47890	47820	107	101	131	140	3.5	3.3	32.3	0.45	1.3	0.74	1.46	0.664	
42362	42584	107	101	134	142	3.5	3	31.8	0.49	1.2	0.67	1.29	0.553	
598	592 A	107	101	135	144	3.5	3.2	37.1	0.44	1.4	0.75	1.6	1.06	
598 A	592 A	113	101	135	144	6.4	3.2	37.1	0.44	1.4	0.75	1.59	1.06	
681	672	110	104	149	160	3.5	3.3	38.3	0.47	1.3	0.70	2.62	1.24	
857	854	121	106	170	174	8	3.3	41.8	0.33	1.8	0.99	4.78	2.55	
42368	42584	107	102	134	142	3	3	31.8	0.49	1.2	0.67	1.24	0.553	
42368	42587	107	102	134	143	3	3.3	34.9	0.49	1.2	0.67	1.24	0.711	
597	592 A	109	102	135	144	3.5	3.2	37.1	0.44	1.4	0.75	1.54	1.06	
▲ JM 719149	▲ JM 719113	109	104	135	143	3	2.5	33.4	0.44	1.4	0.75	1.46	0.765	
47896	47820	110	103	131	140	3.5	3.3	32.3	0.45	1.3	0.74	1.33	0.664	
42375	42584	108	103	134	142	3	3	31.8	0.49	1.2	0.67	1.18	0.553	
42376	42587	109	103	134	143	3.5	3.3	34.9	0.49	1.2	0.67	1.18	0.711	
594	592 A	110	104	135	144	3.5	3.2	37.1	0.44	1.4	0.75	1.47	1.06	
594	592	109	103	135	145	3.5	3.3	37.1	0.44	1.4	0.75	1.47	1.12	
683	672	113	106	149	160	3.5	3.3	38.3	0.47	1.3	0.70	2.47	1.24	
77375	77675	117	105	152	159	3.5	3.3	37.8	0.37	1.6	0.90	2.91	1.67	
776	772	114	107	161	168	3.5	3.3	39.1	0.39	1.6	0.86	3.25	1.99	
864	854	123	108	170	174	8	3.3	41.8	0.33	1.8	0.99	4.57	2.55	
HH 221440	HH 221410	125	110	171	179	8	3.3	42.3	0.33	1.8	0.99	5.0	2.24	
42381	42584	110	104	134	142	3.5	3	31.8	0.49	1.2	0.67	1.13	0.553	
42381	42587	111	105	135	143	3.5	3.3	34.9	0.49	1.2	0.67	1.13	0.711	
52387	52637	114	108	144	154	3.5	3.3	36.1	0.47	1.3	0.69	1.89	0.942	
685	672	116	109	149	160	3.5	3.3	38.3	0.47	1.3	0.70	2.32	1.24	
779	772	116	110	161	168	3.5	3.3	39.1	0.39	1.6	0.86	3.06	1.99	
866	854	118	111	170	174	3.5	3.3	41.8	0.33	1.8	0.99	4.38	2.55	
HH 221442	HH 221410	119	113	171	179	3.5	3.3	42.3	0.33	1.8	0.99	4.81	2.24	
HH 221447	HH 221410	126	114	171	179	6.4	3.3	42.3	0.33	1.8	0.99	4.68	2.24	
▲ JLM 820048	▲ JLM 820012	111	107	135	144	2.3	2.3	36.8	0.50	1.2	0.66	1.27	0.616	
▲ JM 720249	▲ JM 720210	115	109	140	149	3	2.5	36.8	0.47	1.3	0.70	1.68	0.772	
▲ JHM 720249	▲ JHM 720210	117	109	143	154	3	2.5	38.2	0.47	1.3	0.70	2.09	0.974	
52393	52618	116	109	142	152	3.5	3.3	36.1	0.47	1.3	0.69	1.81	0.702	

Note ▲ The tolerances are listed in Tables 2, 3 and 4 on Pages B139 and B140.



# Single-Row Tapered Roller Bearings (Inch Design)

Bore Diameter 101.600 - 117.475 mm

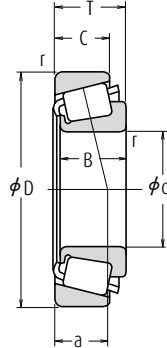

d	Boundary Dimensions (mm)					Cone		Basic Load Ratings (N)				Limiting Speeds (min <sup>-1</sup> )	
	D	T	B	C	r	min.	C <sub>r</sub>	C <sub>or</sub>	C <sub>r</sub>	C <sub>or</sub>	Grease	Oil	
101.600	157.162	36.512	36.116	26.195	3.5	3.3	191 000	310 000	19 500	31 500	2 000	2 800	
	161.925	36.512	36.116	26.195	3.5	3.3	191 000	310 000	19 500	31 500	2 000	2 800	
168.275	41.275	41.275	30.162	3.5	3.3	223 000	345 000	22 700	35 000	2 000	2 800		
180.975	47.625	48.006	38.100	3.5	3.3	258 000	375 000	26 300	38 500	2 000	2 600		
190.500	57.150	57.531	44.450	8.0	3.3	355 000	500 000	36 000	51 000	1 900	2 600		
190.500	57.150	57.531	46.038	8.0	3.3	390 000	520 000	39 500	53 500	1 900	2 600		
212.725	66.675	66.675	53.975	7.0	3.3	570 000	810 000	58 000	82 500	1 700	2 200		
104.775	180.975	47.625	48.006	38.100	7.0	3.3	258 000	375 000	26 300	38 500	2 000	2 600	
	180.975	47.625	48.006	38.100	3.5	3.3	258 000	375 000	26 300	38 500	2 000	2 600	
190.500	47.625	49.212	34.925	3.5	3.3	296 000	465 000	30 000	47 000	1 800	2 400		
106.362	165.100	36.512	36.512	26.988	3.5	3.3	195 000	320 000	19 800	33 000	2 000	2 600	
	158.750	23.020	21.438	15.875	3.5	3.3	102 000	165 000	10 400	16 800	2 000	2 800	
107.950	159.987	34.925	34.925	26.988	3.5	3.3	164 000	315 000	16 700	32 000	2 000	2 800	
	161.925	34.925	34.925	26.988	3.5	3.3	164 000	280 000	16 800	28 600	2 000	2 800	
165.100	36.512	36.512	26.988	3.5	3.3	195 000	320 000	19 800	33 000	2 000	2 600		
190.500	47.625	49.212	34.925	3.5	3.3	296 000	465 000	30 000	47 000	1 800	2 400		
212.725	66.675	66.675	53.975	8.0	3.3	570 000	810 000	58 000	82 500	1 700	2 200		
109.987	159.987	34.925	34.925	26.988	3.5	3.3	164 000	315 000	16 700	32 000	2 000	2 800	
	159.987	34.925	34.925	26.988	8.0	3.3	164 000	315 000	16 700	32 000	2 000	2 800	
109.992	177.800	41.275	41.275	30.162	3.5	3.3	232 000	375 000	23 700	38 000	1 800	2 600	
110.000	165.000	35.000	35.000	26.500	3.0	2.5	195 000	320 000	19 800	33 000	2 000	2 600	
	180.000	47.000	46.000	38.000	3.0	2.5	310 000	490 000	31 500	50 000	1 900	2 600	
111.125	190.500	47.625	49.212	34.925	3.5	3.3	296 000	465 000	30 000	47 000	1 800	2 400	
114.300	152.400	21.433	21.433	16.670	1.5	1.5	89 500	178 000	9 100	18 100	2 000	2 800	
	177.800	41.275	41.275	30.162	3.5	3.3	232 000	375 000	23 700	38 000	1 800	2 600	
180.000	34.925	31.750	25.400	3.5	0.8	174 000	254 000	17 800	25 900	1 800	2 400		
190.500	47.625	49.212	34.925	3.5	3.3	296 000	465 000	30 000	47 000	1 800	2 400		
212.725	66.675	66.675	53.975	7.0	3.3	475 000	700 000	48 500	71 500	1 700	2 400		
212.725	66.675	66.675	53.975	7.0	3.3	570 000	810 000	58 000	82 500	1 700	2 200		
115.087	190.500	47.625	49.212	34.925	3.5	3.3	296 000	465 000	30 000	47 000	1 800	2 400	
117.475	180.975	34.925	31.750	25.400	3.5	3.3	174 000	254 000	17 800	25 900	1 800	2 400	

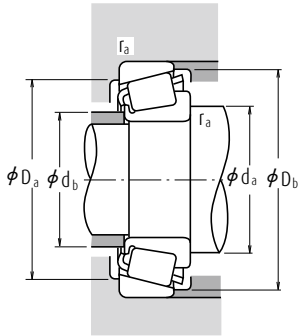

**Dynamic Equivalent Load**  $P = X F_r + Y F_a$

$F_a/F_r \leq e$		$F_a/F_r > e$	
X	Y	X	Y
1	0	0.4	$Y_1$

**Static Equivalent Load**

$$P_0 = 0.5 F_r + Y_0 F_a$$

When  $F_r > 0.5 F_r + Y_0 F_a$ , use  $P_0 = F_r$

The values of  $e$ ,  $Y_1$  and  $Y_0$  are given in the table below.

Bearing Numbers		Abutment and Fillet Dimensions (mm)					Cone	Cup	Eff. Load Centers (mm)	Constant	Axial Load Factors		Mass (kg)	
CONE	CUP	$d_a$	$d_b$	$D_a$	$D_b$	$r_a$ max.					a	e	$Y_1$	$Y_0$
52400	52618	117	111	142	152	3.5	3.3	36.1	0.47	1.3	0.69	1.75	0.702	
52400	52637	117	111	144	154	3.5	3.3	36.1	0.47	1.3	0.69	1.75	0.942	
687	672	118	112	149	160	3.5	3.3	38.3	0.47	1.3	0.70	2.15	1.24	
780	772	119	113	161	168	3.5	3.3	39.1	0.39	1.6	0.86	2.88	1.99	
861	854	129	114	170	174	8	3.3	41.8	0.33	1.8	0.99	4.13	2.55	
HH 221449	HH 221410	131	116	171	179	8	3.3	42.3	0.33	1.8	0.99	4.55	2.24	
HH 224335	HH 224310	132	121	192	202	7	3.3	47.3	0.33	1.8	1.0	8.14	3.06	
787	772	129	116	161	168	7	3.3	39.1	0.39	1.6	0.86	2.66	1.99	
782	772	122	116	161	168	3.5	3.3	39.1	0.39	1.6	0.86	2.68	1.99	
71412	71750	124	118	171	181	3.5	3.3	40.1	0.42	1.4	0.79	4.0	1.71	
56418	56650	122	116	149	159	3.5	3.3	38.6	0.50	1.2	0.66	1.87	0.861	
37425	37625	122	115	143	152	3.5	3.3	37.0	0.61	0.99	0.54	0.886	0.488	
LM 522546	LM 522510	122	116	146	154	3.5	3.3	33.7	0.40	1.5	0.82	1.65	0.784	
48190	48120	122	116	146	156	3.5	3.3	38.7	0.51	1.2	0.65	1.59	0.83	
56425	56650	123	117	149	159	3.5	3.3	38.6	0.50	1.2	0.66	1.8	0.861	
71425	71750	126	120	171	181	3.5	3.3	40.1	0.42	1.4	0.79	3.79	1.71	
HH 224340	HH 224310	139	126	192	202	8	3.3	47.3	0.33	1.8	1.0	7.58	3.06	
LM 522549	LM 522510	124	118	146	154	3.5	3.3	33.7	0.40	1.5	0.82	1.55	0.784	
LM 522548	LM 522510	133	118	146	154	8	3.3	33.7	0.40	1.5	0.82	1.53	0.784	
64433	64700	128	121	160	172	3.5	3.3	42.4	0.52	1.2	0.64	2.64	1.11	
▲ JM 822049	▲ JM 822010	124	119	149	159	3	2.5	38.3	0.50	1.2	0.66	1.64	0.842	
▲ JHM 522649	▲ JHM 522610	127	122	162	172	3	2.5	40.9	0.41	1.5	0.81	3.12	1.51	
71437	71750	129	123	171	181	3.5	3.3	40.1	0.42	1.4	0.79	3.58	1.71	
L 623149	L 623110	123	121	143	148	1.5	1.5	27.4	0.41	1.5	0.80	0.725	0.344	
64450	64700	131	125	160	172	3.5	3.3	42.4	0.52	1.2	0.64	2.39	1.11	
68450	** 68709	130	123	165	172	3.5	0.8	40.0	0.50	1.2	0.66	1.95	1.0	
71450	71750	132	125	171	181	3.5	3.3	40.1	0.42	1.4	0.79	3.37	1.71	
938	932	141	128	187	193	7	3.3	46.9	0.33	1.8	1.0	6.01	4.11	
HH 224346	HH 224310	143	131	192	202	7	3.3	47.3	0.33	1.8	1.0	7.01	3.06	
71453	71750	133	126	171	181	3.5	3.3	40.1	0.42	1.4	0.79	3.31	1.71	
68462	68712	132	125	163	172	3.5	3.3	40.0	0.50	1.2	0.66	1.73	1.05	

**Notes** \*\* The maximum outside diameter is listed and its tolerance is negative (See Table 8.4.2 on Pages A70 and A71).

▲ The tolerances are listed in Tables 2, 3 and 4 on Pages B139 and B140.

# Single-Row Tapered Roller Bearings (Inch Design)

Bore Diameter 120.000 – 165.100 mm

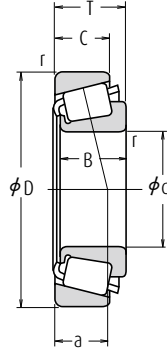

Boundary Dimensions (mm)							Basic Load Ratings (N) {kgf}				Limiting Speeds (min <sup>-1</sup> )	
d	D	T	B	C	Cone	Cup	C <sub>r</sub>	C <sub>0r</sub>	C <sub>r</sub>	C <sub>0r</sub>	Grease	Oil
					r	r						
					min.	min.						
120.000	170.000	25.400	25.400	19.050	3.3	3.3	130 000	219 000	13 200	22 300	1 900	2 600
	174.625	35.720	36.512	27.783	3.5	1.5	212 000	385 000	21 600	39 000	1 900	2 600
120.650	182.562	39.688	38.100	33.338	3.5	3.3	228 000	445 000	23 200	45 000	1 800	2 400
	206.375	47.625	47.625	34.925	3.3	3.3	320 000	530 000	32 500	54 000	1 600	2 200
123.825	182.562	39.688	38.100	33.338	3.5	3.3	228 000	445 000	23 200	45 000	1 800	2 400
125.000	175.000	25.400	25.400	18.288	3.3	3.3	134 000	232 000	13 700	23 600	1 800	2 400
127.000	165.895	18.258	17.462	13.495	1.5	1.5	84 500	149 000	8 650	15 200	1 900	2 600
	182.562	39.688	38.100	33.338	3.5	3.3	228 000	445 000	23 200	45 000	1 800	2 400
	196.850	46.038	46.038	38.100	3.5	3.3	315 000	560 000	32 000	57 500	1 700	2 200
	215.900	47.625	47.625	34.925	3.5	3.3	287 000	495 000	29 300	50 000	1 500	2 000
128.588	206.375	47.625	47.625	34.925	3.3	3.3	320 000	530 000	32 500	54 000	1 600	2 200
	206.375	47.625	47.625	34.925	3.5	3.3	320 000	530 000	32 500	54 000	1 600	2 200
130.175	203.200	46.038	46.038	38.100	3.5	3.3	315 000	560 000	32 000	57 500	1 700	2 200
	206.375	47.625	47.625	34.925	3.5	3.3	320 000	530 000	32 500	54 000	1 600	2 200
133.350	177.008	25.400	26.195	20.638	1.5	1.5	124 000	258 000	12 700	26 300	1 800	2 400
	190.500	39.688	39.688	33.338	3.5	3.3	240 000	485 000	24 500	49 500	1 700	2 200
	196.850	46.038	46.038	38.100	3.5	3.3	315 000	560 000	32 000	57 500	1 700	2 200
	215.900	47.625	47.625	34.925	3.5	3.3	287 000	495 000	29 300	50 000	1 500	2 000
136.525	190.500	39.688	39.688	33.338	3.5	3.3	216 000	440 000	22 000	45 000	1 700	2 200
	217.488	47.625	47.625	34.925	3.5	3.3	287 000	495 000	29 300	50 000	1 500	2 000
139.700	187.325	28.575	29.370	23.020	1.5	1.5	153 000	305 000	15 600	31 500	1 700	2 200
	215.900	47.625	47.625	34.925	3.5	3.3	287 000	495 000	29 300	50 000	1 500	2 000
142.875	254.000	66.675	66.675	47.625	7.0	3.3	515 000	830 000	52 500	84 500	1 300	1 800
	200.025	41.275	39.688	34.130	3.5	3.3	227 000	460 000	23 100	46 500	1 600	2 200
146.050	193.675	28.575	28.575	23.020	1.5	1.5	170 000	355 000	17 300	36 500	1 600	2 200
	236.538	57.150	56.642	44.450	3.5	3.3	455 000	720 000	46 000	73 500	1 400	1 900
149.225	254.000	66.675	66.675	47.625	7.0	3.3	515 000	830 000	52 500	84 500	1 300	1 800
	254.000	66.675	66.675	47.625	7.0	3.3	515 000	830 000	52 500	84 500	1 300	1 800
152.400	254.000	66.675	66.675	47.625	7.0	3.3	515 000	830 000	52 500	84 500	1 300	1 800
158.750	225.425	41.275	39.688	33.338	3.5	3.3	240 000	540 000	24 400	55 000	1 400	1 900
165.100	247.650	47.625	47.625	38.100	3.5	3.3	345 000	705 000	35 500	71 500	1 300	1 700

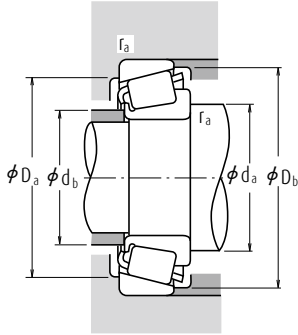

**Dynamic Equivalent Load**  $P = X F_r + Y F_a$

$F_a/F_r \leq e$		$F_a/F_r > e$	
X	Y	X	Y
1	0	0.4	$Y_1$

**Static Equivalent Load**

$P_0 = 0.5 F_r + Y_0 F_a$   
 When  $F_r > 0.5 F_r + Y_0 F_a$ , use  $P_0 = F_r$

The values of  $e$ ,  $Y_1$  and  $Y_0$  are given in the table below.

Bearing Numbers		Abutment and Fillet Dimensions (mm)					Eff. Load Centers (mm)	Constant	Axial Load Factors		Mass (kg)		
CONE	CUP	$d_a$	$d_b$	$D_a$	$D_b$	Cone Cup $r_a$ max.			a	e	$Y_1$	$Y_0$	approx. CONE
▲ JL 724348	▲ JL 724314	132	127	156	163	3.3	3.3	32.9	0.46	1.3	0.72	1.08	0.591
* M 224748	M 224710	135	129	163	168	3.5	1.5	32.2	0.33	1.8	0.99	1.9	0.866
48282	48220	136	133	168	176	3.5	3.3	34.2	0.31	2.0	1.1	2.56	1.14
795	792	139	134	186	198	3.3	3.3	45.7	0.46	1.3	0.72	4.44	1.9
48286	48220	139	133	168	176	3.5	3.3	34.2	0.31	2.0	1.1	2.37	1.14
▲ JL 725346	▲ JL 725316	138	133	161	168	3.3	3.3	34.3	0.48	1.3	0.69	1.19	0.573
LL 225749	LL 225710	135	132	158	160	1.5	1.5	24.2	0.33	1.8	0.99	0.647	0.288
48290	48220	141	135	168	176	3.5	3.3	34.2	0.31	2.0	1.1	2.19	1.14
67388	67322	144	138	180	189	3.5	3.3	39.7	0.34	1.7	0.96	3.74	1.46
74500	74850	148	141	196	208	3.5	3.3	48.4	0.49	1.2	0.68	4.92	1.99
799	792	146	140	186	198	3.3	3.3	45.7	0.46	1.3	0.72	3.86	1.9
797	792	148	141	186	198	3.5	3.3	45.7	0.46	1.3	0.72	3.76	1.9
67389	67320	146	141	183	191	3.5	3.3	39.7	0.34	1.7	0.96	3.51	2.06
799 A	792	148	142	186	198	3.5	3.3	45.7	0.46	1.3	0.72	3.74	1.9
L 327249	L 327210	143	141	167	171	1.5	1.5	29.5	0.35	1.7	0.95	1.18	0.55
48385	48320	148	142	177	184	3.5	3.3	35.9	0.32	1.9	1.0	2.58	1.16
67390	67322	149	143	180	189	3.5	3.3	39.7	0.34	1.7	0.96	3.27	1.46
74525	74850	152	146	196	208	3.5	3.3	48.4	0.49	1.2	0.68	4.44	1.99
48393	48320	151	144	177	184	3.5	3.3	35.9	0.32	1.9	1.0	2.31	1.16
74537	74856	155	148	197	210	3.5	3.3	48.4	0.49	1.2	0.68	4.19	2.13
LM 328448	LM 328410	149	147	176	182	1.5	1.5	31.7	0.36	1.7	0.93	1.59	0.67
74550	74850	158	151	196	208	3.5	3.3	48.4	0.49	1.2	0.68	3.93	1.99
99550	99100	170	156	227	238	7	3.3	55.3	0.41	1.5	0.81	9.99	3.83
48685	48620	158	151	185	193	3.5	3.3	37.6	0.34	1.8	0.98	2.63	1.19
36690	36620	155	154	182	188	1.5	1.5	33.5	0.37	1.6	0.90	1.64	0.725
HM 231140	HM 231110	164	160	217	224	3.5	3.3	45.9	0.32	1.9	1.0	6.07	2.93
99575	99100	175	162	227	238	7	3.3	55.3	0.41	1.5	0.81	9.24	3.83
99587	99100	178	165	227	238	7	3.3	55.3	0.41	1.5	0.81	8.86	3.83
99600	99100	181	167	227	238	7	3.3	55.3	0.41	1.5	0.81	8.46	3.83
46780	46720	176	169	209	218	3.5	3.3	44.3	0.38	1.6	0.86	3.69	1.66
67780	67720	185	179	229	240	3.5	3.3	52.4	0.44	1.4	0.75	5.83	2.33

- Notes**
- \* The maximum bore diameter is listed and its tolerance is negative (See Table 8.4.1 on Page A70).
  - ▲ The tolerances are listed in Tables 2, 3 and 4 on Pages B139 and B140.

# Single-Row Tapered Roller Bearings (Inch Design)

Bore Diameter 170.000 – 206.375 mm

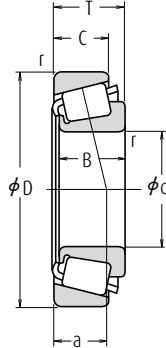

Boundary Dimensions (mm)							Basic Load Ratings (N) {kgf}				Limiting Speeds (min <sup>-1</sup> )	
d	D	T	B	C	Cone Cup		C <sub>r</sub>	C <sub>0r</sub>	C <sub>r</sub>	C <sub>0r</sub>	Grease	Oil
					r	r min.						
<b>170.000</b>	230.000	39.000	38.000	31.000	3.0	2.5	278 000	520 000	28 300	53 000	1 300	1 800
	240.000	46.000	44.500	37.000	3.0	2.5	380 000	720 000	39 000	73 000	1 300	1 800
<b>174.625</b>	247.650	47.625	47.625	38.100	3.5	3.3	345 000	705 000	35 500	71 500	1 300	1 700
	<b>177.800</b>	227.012	30.162	30.162	23.020	1.5	1.5	181 000	415 000	18 500	42 000	1 300
<b>177.800</b>	247.650	47.625	47.625	38.100	3.5	3.3	345 000	705 000	35 500	71 500	1 300	1 700
	260.350	53.975	53.975	41.275	3.5	3.3	455 000	835 000	46 500	85 000	1 200	1 700
	<b>190.000</b>	260.000	46.000	44.000	36.500	3.0	2.5	370 000	730 000	38 000	74 500	1 100
<b>190.500</b>	266.700	47.625	46.833	38.100	3.5	3.3	345 000	720 000	35 000	73 000	1 100	1 500
<b>200.000</b>	300.000	65.000	62.000	51.000	3.5	2.5	615 000	1 130 000	62 500	116 000	1 000	1 400
<b>203.200</b>	282.575	46.038	46.038	36.512	3.5	3.3	365 000	800 000	37 500	81 500	1 000	1 400
<b>206.375</b>	282.575	46.038	46.038	36.512	3.5	3.3	365 000	800 000	37 500	81 500	1 000	1 400

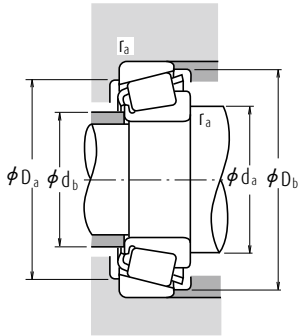

### Dynamic Equivalent Load $P = XF_r + YF_a$

$F_a/F_r \leq e$		$F_a/F_r > e$	
X	Y	X	Y
1	0	0.4	$Y_1$

### Static Equivalent Load

$$P_0 = 0.5F_r + Y_0F_a$$

When  $F_r > 0.5F_r + Y_0F_a$ , use  $P_0 = F_r$

The values of  $e$ ,  $Y_1$  and  $Y_0$  are given in the table below.

Bearing Numbers		Abutment and Fillet Dimensions (mm)						Eff. Load Centers (mm)	Constant	Axial Load Factors		Mass (kg)	
CONE	CUP	$d_a$	$d_b$	$D_a$	$D_b$	Cone $r_a$ max.	Cup			$e$	$Y_1$	$Y_0$	CONE
▲ JHM 534149	▲ JHM 534110	184	178	217	224	3	2.5	43.2	0.38	1.6	0.86	3.1	1.3
▲ JM 734449	▲ JM 734410	185	180	222	232	3	2.5	50.5	0.44	1.4	0.75	4.42	2.02
67787	67720	192	185	229	240	3.5	3.3	52.4	0.44	1.4	0.75	4.88	2.33
36990	36920	189	186	214	221	1.5	1.5	42.9	0.44	1.4	0.75	2.1	0.907
67790	67720	194	188	229	240	3.5	3.3	52.4	0.44	1.4	0.75	4.56	2.33
M 236849	M 236810	195	192	241	249	3.5	3.3	47.5	0.33	1.8	0.99	6.49	2.86
▲ JM 738249	▲ JM 738210	206	200	242	252	3	2.5	56.4	0.48	1.3	0.69	4.73	2.2
67885	67820	209	203	246	259	3.5	3.3	57.9	0.48	1.3	0.69	5.4	2.64
▲ JHM 840449	▲ JHM 840410	223	215	273	289	3.5	2.5	73.1	0.52	1.2	0.63	10.3	5.19
67983	67920	222	216	260	275	3.5	3.3	61.9	0.51	1.2	0.65	6.03	2.82
67985	67920	224	219	260	275	3.5	3.3	61.9	0.51	1.2	0.65	5.66	2.82

**Note** ▲ The tolerances are listed in Tables 2, 3 and 4 on Pages B139 and B140.

# Double-Row Tapered Roller Bearings

Bore Diameter 40 - 90 mm

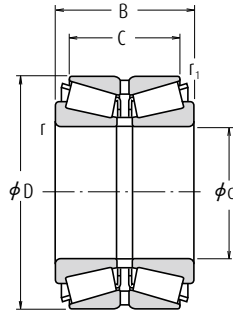

Boundary Dimensions (mm)						Basic Load Ratings (N)		Limiting Speeds (min <sup>-1</sup> )	
d	D	B <sub>2</sub>	C	r min.	r <sub>1</sub> min.	C <sub>r</sub>	C <sub>0r</sub>	Grease	Oil
40	80	45	37.5	1.5	0.6	109 000	140 000	3 700	5 100
45	85	47	37.5	1.5	0.6	117 000	159 000	3 400	4 700
	85	55	43.5	1.5	0.6	143 000	204 000	3 400	4 700
50	90	48	38.5	1.5	0.6	131 000	183 000	3 200	4 400
	90	49	39.5	1.5	0.6	131 000	183 000	3 200	4 400
	90	55	43.5	1.5	0.6	150 000	218 000	3 200	4 400
	110	64	51.5	2.5	0.6	224 000	297 000	2 700	3 700
55	100	51	41.5	2	0.6	162 000	226 000	2 900	3 900
	100	52	42.5	2	0.6	162 000	226 000	2 900	3 900
	100	60	48.5	2	0.6	188 000	274 000	2 900	3 900
	120	70	57	2.5	0.6	256 000	342 000	2 500	3 400
60	110	53	43.5	2	0.6	178 000	246 000	2 700	3 600
	110	66	54.5	2	0.6	225 000	335 000	2 700	3 600
	130	74	59	3	1	298 000	405 000	2 300	3 200
65	120	56	46.5	2	0.6	210 000	300 000	2 400	3 200
	120	57	47.5	2	0.6	210 000	300 000	2 400	3 200
	120	73	61.5	2	0.6	269 000	405 000	2 400	3 300
65	140	79	63	3	1	340 000	465 000	2 100	2 900
70	125	57	46.5	2	0.6	227 000	325 000	2 300	3 100
	125	59	48.5	2	0.6	227 000	325 000	2 300	3 100
	125	74	61.5	2	0.6	270 000	410 000	2 300	3 100
	150	83	67	3	1	390 000	535 000	2 000	2 700
75	130	62	51.5	2	0.6	245 000	365 000	2 200	3 000
	130	74	61.5	2	0.6	283 000	440 000	2 200	3 000
	160	87	69	3	1	435 000	600 000	1 900	2 500
80	140	61	49	2.5	0.6	269 000	390 000	2 000	2 800
	140	64	51.5	2.5	0.6	269 000	390 000	2 000	2 800
	140	78	63.5	2.5	0.6	330 000	505 000	2 000	2 800
	170	92	73	3	1	475 000	655 000	1 700	2 400
85	150	70	57	2.5	0.6	315 000	465 000	1 900	2 600
	150	86	69	2.5	0.6	360 000	555 000	1 900	2 600
	180	98	77	4	1	530 000	745 000	1 600	2 200
90	160	71	58	2.5	0.6	345 000	510 000	1 800	2 400
	160	74	61	2.5	0.6	345 000	510 000	1 800	2 400
	160	94	77	2.5	0.6	440 000	700 000	1 800	2 400

**Remarks** For other double-row tapered roller bearings not listed above, please contact NSK.

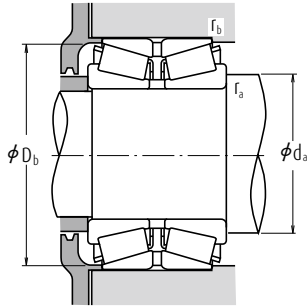

**Dynamic Equivalent Load**  $P = X F_r + Y F_a$

$F_a/F_r \leq e$		$F_a/F_r > e$	
X	Y	X	Y
1	$Y_3$	0.67	$Y_3$

**Static Equivalent Load**

$$P_0 = F_r + Y_0 F_a$$

The values of  $e$ ,  $Y_2$ ,  $Y_3$  and  $Y_0$  are given in the table below.

Bearing Numbers	Abutment and Fillet Dimensions (mm)				Constant $e$	Axial Load Factors			Mass (kg) approx.
	$d_a$ min.	$D_b$ min.	$r_a$ max.	$r_b$ max.		$Y_2$	$Y_3$	$Y_0$	
HR 40 KBE 42+L	51	75	1.5	0.6	0.37	2.7	1.8	1.8	0.97
HR 45 KBE 42+L	56	81	1.5	0.6	0.40	2.5	1.7	1.6	1.08
HR 45 KBE 52X+L	56	81	1.5	0.6	0.40	2.5	1.7	1.6	1.31
HR 50 KBE 042+L	61	87	1.5	0.6	0.42	2.4	1.6	1.6	1.20
HR 50 KBE 42+L	61	87	1.5	0.6	0.42	2.4	1.6	1.6	1.22
HR 50 KBE 52X+L	61	87	1.5	0.6	0.42	2.4	1.6	1.6	1.39
HR 50 KBE 043+L	65	104	2	0.6	0.35	2.9	2.0	1.9	2.77
HR 55 KBE 042+L	67	96	2	0.6	0.40	2.5	1.7	1.6	1.59
HR 55 KBE 1003+L	67	96	2	0.6	0.40	2.5	1.7	1.6	1.63
HR 55 KBE 52X+L	67	97	2	0.6	0.40	2.5	1.7	1.6	1.88
HR 55 KBE 43+L	70	113	2	0.6	0.35	2.9	2.0	1.9	3.52
HR 60 KBE 042+L	72	105	2	0.6	0.40	2.5	1.7	1.6	2.03
HR 60 KBE 52X+L	72	106	2	0.6	0.40	2.5	1.7	1.6	2.52
HR 60 KBE 43+L	78	122	2.5	1	0.35	2.9	2.0	1.9	4.40
HR 65 KBE 42+L	77	115	2	0.6	0.40	2.5	1.7	1.6	2.58
HR 65 KBE 1202+L	77	115	2	0.6	0.40	2.5	1.7	1.6	2.61
HR 65 KBE 52X+L	77	117	2	0.6	0.40	2.5	1.7	1.6	3.35
HR 65 KBE 43+L	83	132	2.5	1	0.35	2.9	2.0	1.9	5.42
HR 70 KBE 042+L	82	120	2	0.6	0.42	2.4	1.6	1.6	2.79
HR 70 KBE 42+L	82	120	2	0.6	0.42	2.4	1.6	1.6	2.85
HR 70 KBE 52X+L	82	121	2	0.6	0.42	2.4	1.6	1.6	3.58
HR 70 KBE 43+L	88	142	2.5	1	0.35	2.9	2.0	1.9	6.45
HR 75 KBE 42+L	87	126	2	0.6	0.44	2.3	1.6	1.5	3.15
HR 75 KBE 52X+L	87	127	2	0.6	0.44	2.3	1.6	1.5	3.73
HR 75 KBE 043+L	93	151	2.5	1	0.35	2.9	2.0	1.9	7.66
HR 80 KBE 042+L	95	134	2	0.6	0.42	2.4	1.6	1.6	3.70
HR 80 KBE 42+L	95	134	2	0.6	0.42	2.4	1.6	1.6	3.70
HR 80 KBE 52X+L	95	136	2	0.6	0.42	2.4	1.6	1.6	4.59
HR 80 KBE 043+L	98	161	2.5	1	0.35	2.9	2.0	1.9	9.02
HR 85 KBE 42+L	100	143	2	0.6	0.42	2.4	1.6	1.6	4.69
HR 85 KBE 52X+L	100	144	2	0.6	0.42	2.4	1.6	1.6	5.70
HR 85 KBE 043+L	106	169	3	1	0.35	2.9	2.0	1.9	10.8
HR 90 KBE 042+L	105	152	2	0.6	0.42	2.4	1.6	1.6	5.53
HR 90 KBE 42+L	105	152	2	0.6	0.42	2.4	1.6	1.6	5.71
HR 90 KBE 52X+L	105	154	2	0.6	0.42	2.4	1.6	1.6	7.26



# Double-Row Tapered Roller Bearings

Bore Diameter 90 – 120 mm

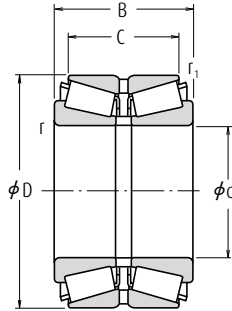

Boundary Dimensions (mm)						Basic Load Ratings (N)		Limiting Speeds (min <sup>-1</sup> )	
d	D	B <sub>2</sub>	C	r min.	r <sub>1</sub> min.	C <sub>r</sub>	C <sub>0r</sub>	Grease	Oil
90	190	102	81	4	1	595 000	845 000	1 600	2 100
	190	144	115	4	1	770 000	1 180 000	1 600	2 200
95	170	78	63	3	1	385 000	570 000	1 700	2 300
	170	100	83	3	1	495 000	800 000	1 700	2 300
100	200	108	85	4	1	640 000	910 000	1 500	2 000
	165	52	46	2.5	0.6	222 000	340 000	1 700	2 300
	180	81	64	3	1	435 000	665 000	1 600	2 200
	180	81	65	3	1	435 000	665 000	1 600	2 200
	180	82	66	3	1	435 000	665 000	1 600	2 200
	180	83	67	3	1	435 000	665 000	1 600	2 200
	180	105	85	3	1	555 000	905 000	1 600	2 200
	180	107	87	3	1	555 000	905 000	1 600	2 200
105	180	110	90	3	1	555 000	905 000	1 600	2 200
	215	112	87	4	1	725 000	1 050 000	1 400	1 900
	190	88	70	3	1	480 000	735 000	1 500	2 000
	190	117	96	3	1	620 000	1 020 000	1 500	2 000
	190	115	95	3	1	620 000	1 020 000	1 500	2 000
	225	116	91	4	1	780 000	1 130 000	1 300	1 800
110	180	56	50	2.5	0.6	264 000	400 000	1 500	2 000
	180	70	56	2.5	0.6	340 000	555 000	1 500	2 000
	180	125	100	2.5	0.6	550 000	1 060 000	1 500	2 100
	200	90	72	3	1	540 000	840 000	1 400	1 900
	200	92	74	3	1	540 000	840 000	1 400	1 900
	200	120	100	3	1	685 000	1 130 000	1 400	1 900
	200	121	101	3	1	685 000	1 130 000	1 400	1 900
	240	118	93	4	1.5	830 000	1 190 000	1 200	1 700
120	180	46	41	2.5	0.6	184 000	296 000	1 500	2 000
	180	58	46	2.5	0.6	260 000	450 000	1 500	2 000
	200	62	55	2.5	0.6	310 000	500 000	1 400	1 800
	200	78	62	2.5	0.6	415 000	690 000	1 400	1 900
	200	100	84	2.5	0.6	515 000	885 000	1 400	1 800
	215	97	78	3	1	575 000	900 000	1 300	1 800
	215	132	109	3	1	750 000	1 270 000	1 300	1 800
	260	128	101	4	1	915 000	1 310 000	1 100	1 500
	260	188	145	4	1	1 320 000	2 110 000	1 100	1 500

**Remarks** For other double-row tapered roller bearings not listed above, please contact NSK.

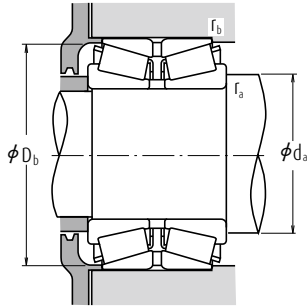

**Dynamic Equivalent Load**  $P = X F_r + Y F_a$

$F_a/F_r \leq e$		$F_a/F_r > e$	
X	Y	X	Y
1	$Y_3$	0.67	$Y_3$

**Static Equivalent Load**

$$P_0 = F_r + Y_0 F_a$$

The values of  $e$ ,  $Y_2$ ,  $Y_3$  and  $Y_0$  are given in the table below.

Bearing Numbers	Abutment and Fillet Dimensions (mm)				Constant $e$	Axial Load Factors			Mass (kg) approx.
	$d_a$ min.	$D_b$ min.	$r_a$ max.	$r_b$ max.		$Y_2$	$Y_3$	$Y_0$	
HR 90 KBE 043+L	111	178	3	1	0.35	2.9	2.0	1.9	12.7
HR 90 KBE 1901+L	111	179	3	1	0.35	2.9	2.0	1.9	17.9
HR 95 KBE 42+L	113	161	2.5	1	0.42	2.4	1.6	1.6	6.75
HR 95 KBE 52+L	113	163	2.5	1	0.42	2.4	1.6	1.6	8.60
HR 95 KBE 43+L	116	187	3	1	0.35	2.9	2.0	1.9	14.7
100 KBE 31+L	115	156	2	0.6	0.33	3.0	2.0	2.0	4.04
HR100 KBE 1805+L	118	170	2.5	1	0.42	2.4	1.6	1.6	8.16
HR100 KBE 042+L	118	170	2.5	1	0.42	2.4	1.6	1.6	8.13
HR100 KBE 1801+L	118	170	2.5	1	0.42	2.4	1.6	1.6	8.22
HR100 KBE 42+L	118	170	2.5	1	0.42	2.4	1.6	1.6	8.7
HR100 KBE 1802+L	118	173	2.5	1	0.42	2.4	1.6	1.6	10.6
HR100 KBE 52X+L	118	173	2.5	1	0.42	2.4	1.6	1.6	10.7
HR100 KBE 1804+L	118	173	2.5	1	0.42	2.4	1.6	1.6	11
HR100 KBE 043+L	121	200	3	1	0.35	2.9	2.0	1.9	18.1
HR105 KBE 42X+L	123	179	2.5	1	0.42	2.4	1.6	1.6	9.76
HR105 KBE 1902+L	123	182	2.5	1	0.42	2.4	1.6	1.6	13.4
HR105 KBE 52+L	123	182	2.5	1	0.42	2.4	1.6	1.6	13.1
HR105 KBE 043+L	126	209	3	1	0.35	2.9	2.0	1.9	20.4
110 KBE 31+L	125	172	2	0.6	0.39	2.6	1.7	1.7	5.11
110 KBE 031+L	125	172	2	0.6	0.39	2.6	1.7	1.7	6.33
110 KBE 1802+L	125	172	2	0.6	0.26	3.8	2.6	2.5	11.4
HR110 KBE 42+L	128	190	2.5	1	0.42	2.4	1.6	1.6	11.2
HR110 KBE 42X+L	128	190	2.5	1	0.42	2.4	1.6	1.6	11.5
HR110 KBE 2001+L	128	193	2.5	1	0.42	2.4	1.6	1.6	15.4
HR110 KBE 52X+L	128	193	2.5	1	0.42	2.4	1.6	1.6	15.2
HR110 KBE 043+L	131	223	3	1.5	0.35	2.9	2.0	1.9	23.6
120 KBE 30+L	135	172	2	0.6	0.40	2.5	1.7	1.6	3.75
120 KBE 030+L	135	172	2	0.6	0.39	2.6	1.7	1.7	4.64
120 KBE 31+L	135	190	2	0.6	0.39	2.6	1.7	1.7	7.35
120 KBE 031+L	135	190	2	0.6	0.39	2.6	1.7	1.7	8.97
120 KBE 2001+L	135	193	2	0.6	0.37	2.7	1.8	1.8	11.3
HR120 KBE 42X+L	138	204	2.5	1	0.44	2.3	1.6	1.5	13.7
HR120 KBE 52X+L	138	207	2.5	1	0.44	2.3	1.6	1.5	18.8
HR120 KBE 43+L	141	240	3	1	0.35	2.9	2.0	1.9	29.4
HR120 KBE 2601+L	141	242	3	1	0.35	2.9	2.0	1.9	44.6

# Double-Row Tapered Roller Bearings

Bore Diameter 125 – 150 mm

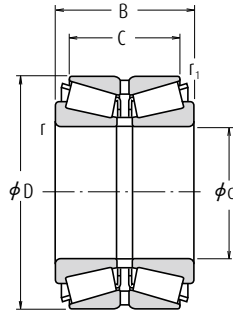

Boundary Dimensions (mm)						Basic Load Ratings (N)		Limiting Speeds (min <sup>-1</sup> )	
d	D	B <sub>2</sub>	C	r min.	r <sub>1</sub> min.	C <sub>r</sub>	C <sub>0r</sub>	Grease	Oil
125	210	110	88	4	1	560 000	1 030 000	1 300	1 800
130	230	98	78.5	4	1	640 000	1 010 000	1 200	1 600
	230	100	80.5	4	1	640 000	1 010 000	1 200	1 600
	280	137	107.5	5	1.5	940 000	1 350 000	1 000	1 400
	230	145	115	4	1	905 000	1 580 000	1 200	1 700
	230	145	117.5	4	1	905 000	1 580 000	1 200	1 700
	230	150	120	4	1	905 000	1 580 000	1 200	1 700
140	210	53	47	2.5	0.6	280 000	495 000	1 200	1 700
	210	66	53	2.5	1	305 000	530 000	1 200	1 700
	210	106	94	2.5	0.6	555 000	1 200 000	1 300	1 700
	225	68	61	3	1	400 000	630 000	1 200	1 600
	225	84	68	3	1	490 000	850 000	1 200	1 600
	225	85	68	3	1	490 000	850 000	1 200	1 600
	230	120	94	3	1	685 000	1 270 000	1 200	1 600
	230	140	110	3	1	820 000	1 550 000	1 200	1 600
	240	132	106	4	1.5	685 000	1 360 000	1 100	1 500
	250	102	82.5	4	1	670 000	1 030 000	1 100	1 500
	250	153	125.5	4	1	1 040 000	1 830 000	1 100	1 500
	300	145	115.5	5	1.5	1 030 000	1 480 000	1 000	1 300
150	225	56	50	3	1	300 000	545 000	1 200	1 600
	225	70	56	3	1	395 000	685 000	1 200	1 600
	250	80	71	3	1	510 000	810 000	1 100	1 400
	250	100	80	3	1	630 000	1 090 000	1 100	1 400
	250	115	95	3	1	745 000	1 320 000	1 100	1 500
	260	150	115	4	1	815 000	1 520 000	1 100	1 400
	270	109	87	4	1	830 000	1 330 000	1 000	1 400
	270	164	130	4	1	1 210 000	2 150 000	1 000	1 400
	270	174	140	4	1	1 210 000	2 150 000	1 000	1 400
	320	154	120	5	1.5	1 420 000	2 130 000	900	1 200

**Remarks** For other double-row tapered roller bearings not listed above, please contact NSK.

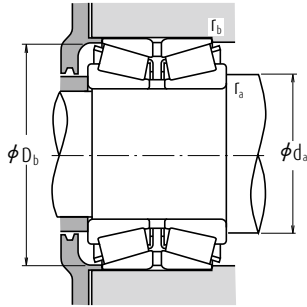

**Dynamic Equivalent Load**  $P = XF_r + YF_a$

$F_a/F_r \leq e$		$F_a/F_r > e$	
X	Y	X	Y
1	$Y_3$	0.67	$Y_3$

**Static Equivalent Load**

$$P_0 = F_r + Y_0 F_a$$

The values of  $e$ ,  $Y_2$ ,  $Y_3$  and  $Y_0$  are given in the table below.

Bearing Numbers	Abutment and Fillet Dimensions (mm)				Constant $e$	Axial Load Factors			Mass (kg) approx.
	$d_a$ min.	$D_b$ min.	$r_a$ max.	$r_b$ max.		$Y_2$	$Y_3$	$Y_0$	
125 KBE 2101+L	146	201	3	1	0.43	2.3	1.6	1.5	14.5
HR130 KBE 42+L	151	220	3	1	0.44	2.3	1.6	1.5	15.8
HR130 KBE 2301+L	151	220	3	1	0.44	2.3	1.6	1.5	15.9
130 KBE 43+L	157	258	4	1.5	0.36	2.8	1.9	1.8	35
HR130 KBE 2302+L	151	221	3	1	0.44	2.3	1.6	1.5	24.1
HR130 KBE 52+L	151	222	3	1	0.44	2.3	1.6	1.5	23.8
HR130 KBE 2303+L	151	221	3	1	0.44	2.3	1.6	1.5	24.2
140 KBE 30+L	155	202	2	0.6	0.39	2.6	1.7	1.7	6.02
140 KBE 030+L	155	202	2	1	0.40	2.5	1.7	1.6	7.02
140 KBE 2101+L	155	202	2	0.6	0.33	3.0	2.0	2.0	12.3
140 KBE 31+L	158	216	2.5	1	0.39	2.6	1.7	1.7	9.31
140 KBE 031+L	158	215	2.5	1	0.39	2.6	1.7	1.7	11.6
140 KBE 2201+L	158	215	2.5	1	0.39	2.6	1.7	1.7	11.7
140 KBE 2301+L	158	220	2.5	1	0.33	3.0	2.0	2.0	17.6
140 KBE 2302+L	158	221	2.5	1	0.35	2.9	2.0	1.9	20.7
140 KBE 2401+L	161	227	3	1.5	0.44	2.3	1.5	1.5	22.7
HR140 KBE 42+L	161	237	3	1	0.44	2.3	1.6	1.5	18.9
HR140 KBE 52X+L	161	241	3	1	0.44	2.3	1.6	1.5	29.6
140 KBE 43+L	167	275	4	1.5	0.36	2.8	1.9	1.8	42.6
150 KBE 30+L	168	213	2.5	1	0.35	2.9	2.0	1.9	7.41
150 KBE 030+L	168	215	2.5	1	0.35	2.9	2.0	1.9	8.70
150 KBE 31+L	168	240	2.5	1	0.40	2.5	1.7	1.6	14.2
150 KBE 031+L	168	238	2.5	1	0.39	2.6	1.7	1.7	17.8
150 KBE 2502+L	168	238	2.5	1	0.37	2.7	1.8	1.8	20.9
150 KBE 2601+L	171	242	3	1	0.43	2.3	1.6	1.5	30.0
HR150 KBE 42+L	171	253	3	1	0.44	2.3	1.6	1.5	24.3
HR150 KBE 52X+L	171	257	3	1	0.44	2.3	1.6	1.5	37.3
HR150 KBE 2701+L	171	257	3	1	0.44	2.3	1.6	1.5	39.7
HR150 KBE 43+L	177	295	4	1.5	0.35	2.9	2.0	1.9	53.4

# Double-Row Tapered Roller Bearings

Bore Diameter 160 – 200 mm

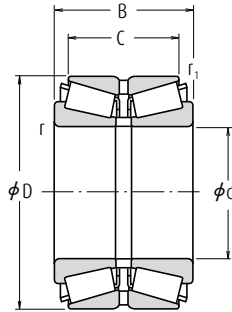

Boundary Dimensions (mm)						Basic Load Ratings (N)		Limiting Speeds (min <sup>-1</sup> )	
d	D	B <sub>2</sub>	C	r min.	r <sub>1</sub> min.	C <sub>r</sub>	C <sub>0r</sub>	Grease	Oil
160	240	60	53	3	1	355 000	580 000	1 100	1 500
	240	75	60	3	1	395 000	710 000	1 100	1 500
	240	110	90	3	1	650 000	1 290 000	1 100	1 500
	270	86	76	3	1	540 000	885 000	1 000	1 300
	270	108	86	3	1	775 000	1 380 000	1 000	1 300
	270	140	120	3	1	990 000	1 880 000	1 000	1 300
	280	150	125	4	1	1 100 000	2 020 000	1 000	1 300
	290	115	91	4	1	800 000	1 220 000	900	1 300
	290	178	144	4	1	1 360 000	2 440 000	1 000	1 300
	340	160	126	5	1.5	1 310 000	1 920 000	800	1 100
165	290	150	125	4	1	1 140 000	2 130 000	900	1 300
170	250	85	65	3	1	435 000	845 000	1 000	1 400
	260	67	60	3	1	400 000	700 000	1 000	1 300
260	84	67	3	1	575 000	1 030 000	1 000	1 300	
280	88	78	3	1	630 000	1 040 000	900	1 300	
280	110	88	3	1	820 000	1 450 000	900	1 300	
280	150	130	3	1	1 110 000	2 160 000	1 000	1 300	
310	192	152	5	1.5	1 590 000	2 910 000	900	1 200	
180	280	74	66	3	1	455 000	810 000	900	1 300
	280	93	74	3	1	655 000	1 220 000	900	1 200
	300	96	85	4	1.5	725 000	1 210 000	900	1 200
	300	120	96	4	1.5	940 000	1 690 000	900	1 200
	320	127	99	5	1.5	895 000	1 390 000	800	1 200
	320	192	152	5	1.5	1 640 000	3 050 000	900	1 200
340	180	140	5	1.5	1 410 000	2 510 000	800	1 100	
190	290	75	67	3	1	490 000	845 000	900	1 200
	290	94	75	3	1	670 000	1 230 000	900	1 200
	320	104	92	4	1.5	800 000	1 380 000	800	1 100
	320	130	104	4	1.5	1 070 000	1 960 000	800	1 100
340	133	105	5	1.5	990 000	1 580 000	800	1 100	
340	204	160	5	1.5	1 910 000	3 550 000	800	1 100	
200	310	152	123	3	1	1 300 000	2 740 000	800	1 100
	320	146	110	5	1.5	990 000	2 120 000	800	1 100
	330	180	140	5	1.5	1 390 000	2 730 000	800	1 100
	340	112	100	4	1.5	940 000	1 670 000	800	1 000
	340	140	112	4	1.5	1 260 000	2 250 000	800	1 000
	360	142	110	5	1.5	1 100 000	1 780 000	700	1 000
	360	218	174	5	1.5	2 070 000	3 850 000	800	1 000

**Remarks** For other double-row tapered roller bearings not listed above, please contact NSK.

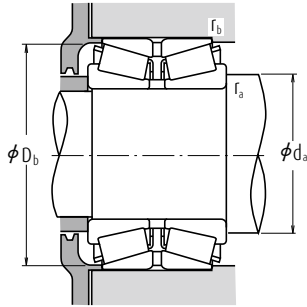

**Dynamic Equivalent Load**  $P = X F_r + Y F_a$

$F_a/F_r \leq e$		$F_a/F_r > e$	
X	Y	X	Y
1	$Y_3$	0.67	$Y_3$

**Static Equivalent Load**

$$P_0 = F_r + Y_0 F_a$$

The values of  $e$ ,  $Y_2$ ,  $Y_3$  and  $Y_0$  are given in the table below.

Bearing Numbers	Abutment and Fillet Dimensions (mm)				Constant $e$	Axial Load Factors			Mass (kg) approx.
	$d_a$ min.	$D_b$ min.	$r_a$ max.	$r_b$ max.		$Y_2$	$Y_3$	$Y_0$	
160 KBE 30+L	178	231	2.5	1	0.37	2.7	1.8	1.8	8.56
160 KBE 030+L	178	230	2.5	1	0.40	2.5	1.7	1.6	10.5
160 KBE 2401+L	178	232	2.5	1	0.38	2.6	1.8	1.7	16.2
160 KBE 31+L	178	255	2.5	1	0.40	2.5	1.7	1.6	18.6
160 KBE 031+L	178	256	2.5	1	0.39	2.6	1.7	1.7	23.1
160 KBE 2701+L	178	261	2.5	1	0.39	2.6	1.7	1.7	30.6
160 KBE 2801+L	181	266	3	1	0.32	3.2	2.1	2.1	35.9
160 KBE 42+L	181	275	3	1	0.43	2.3	1.6	1.5	28.2
HR160 KBE 52X+L	181	277	3	1	0.44	2.3	1.6	1.5	47.3
160 KBE 43+L	187	314	4	1.5	0.36	2.8	1.9	1.8	60.4
165 KBE 2901+L	186	272	3	1	0.33	3.1	2.1	2.0	39.5
170 KBE 2501+L	188	241	2.5	1	0.44	2.3	1.5	1.5	12.3
170 KBE 30+L	188	248	2.5	1	0.40	2.5	1.7	1.6	11.8
170 KBE 030+L	188	249	2.5	1	0.39	2.6	1.7	1.7	14.4
170 KBE 31+L	188	266	2.5	1	0.39	2.6	1.7	1.7	19.7
170 KBE 031+L	188	268	2.5	1	0.39	2.6	1.7	1.7	24.2
170 KBE 2802+L	188	269	2.5	1	0.39	2.6	1.7	1.7	34.6
HR170 KBE 52X+L	197	297	4	1.5	0.44	2.3	1.6	1.5	57.3
180 KBE 30+L	198	265	2.5	1	0.40	2.5	1.7	1.6	15.4
180 KBE 030+L	198	265	2.5	1	0.35	2.9	2.0	1.9	14.4
180 KBE 31+L	201	284	3	1.5	0.39	2.6	1.7	1.7	24.8
180 KBE 031+L	201	287	3	1.5	0.39	2.6	1.7	1.7	31.1
180 KBE 42+L	207	300	4	1.5	0.44	2.3	1.5	1.5	36.5
HR180 KBE 52X+L	207	308	4	1.5	0.45	2.2	1.5	1.5	59.2
180 KBE 3401+L	207	305	4	1.5	0.43	2.3	1.6	1.5	68.1
190 KBE 30+L	208	279	2.5	1	0.39	2.6	1.7	1.7	16.2
190 KBE 030+L	208	279	2.5	1	0.40	2.5	1.7	1.6	20.1
190 KBE 31+L	211	301	3	1.5	0.40	2.5	1.7	1.6	30.9
190 KBE 031+L	211	302	3	1.5	0.39	2.6	1.7	1.7	39.0
190 KBE 42+L	217	320	4	1.5	0.40	2.5	1.7	1.6	43.9
HR190 KBE 52X+L	217	327	4	1.5	0.44	2.3	1.6	1.5	70.8
HR200 KBE 3101+L	218	301	2.5	1	0.43	2.3	1.6	1.5	40.1
200 KBE 3201+L	227	301	4	1.5	0.52	1.9	1.3	1.3	41.6
200 KBE 3301+L	227	316	4	1.5	0.42	2.4	1.6	1.6	54.4
200 KBE 31+L	221	321	3	1.5	0.40	2.5	1.7	1.6	38.8
200 KBE 031+L	221	324	3	1.5	0.39	2.6	1.7	1.7	47.0
200 KBE 42+L	227	338	4	1.5	0.40	2.5	1.7	1.6	52.6
HR200 KBE 52+L	227	344	4	1.5	0.41	2.5	1.7	1.6	88.3

# Double-Row Tapered Roller Bearings

Bore Diameter 206 – 260 mm

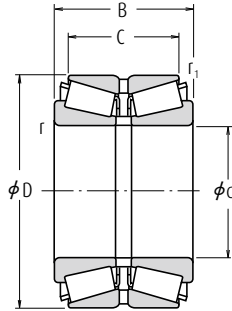

Boundary Dimensions (mm)						Basic Load Ratings (N)		Limiting Speeds (min <sup>-1</sup> )	
d	D	B <sub>2</sub>	C	r min.	r <sub>1</sub> min.	C <sub>r</sub>	C <sub>0r</sub>	Grease	Oil
206	283	102	83	4	1.5	580 000	1 430 000	900	1 200
210	355	116	103	4	1.5	905 000	1 520 000	700	1 000
220	300	110	88	3	1	730 000	1 710 000	800	1 100
	340	90	80	4	1.5	695 000	1 280 000	700	1 000
	340	113	90	4	1.5	920 000	1 830 000	700	1 000
	370	120	107	5	1.5	1 110 000	1 940 000	700	1 000
	370	150	120	5	1.5	1 460 000	2 760 000	700	1 000
	400	158	122	5	1.5	1 390 000	2 300 000	600	900
240	360	92	82	4	1.5	780 000	1 490 000	700	900
	360	115	92	4	1.5	1 020 000	2 040 000	700	900
	400	128	114	5	1.5	1 180 000	2 190 000	600	900
	400	160	128	5	1.5	1 620 000	3 050 000	600	900
	400	209	168	5	1.5	2 220 000	4 450 000	600	900
250	380	98	87	4	1	795 000	1 460 000	600	900
260	400	104	92	5	1.5	895 000	1 670 000	600	800
	400	130	104	5	1.5	1 210 000	2 460 000	600	800
	440	144	128	5	1.5	1 540 000	2 760 000	600	800
	440	172	145	5	1.5	1 870 000	3 500 000	600	800
	440	180	144	5	1.5	2 110 000	4 150 000	600	800

**Remarks** For other double-row tapered roller bearings not listed above, please contact NSK.

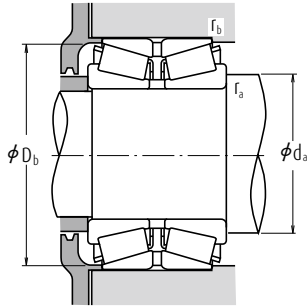

### Dynamic Equivalent Load $P = X F_r + Y F_a$

$F_a/F_r \leq e$		$F_a/F_r > e$	
X	Y	X	Y
1	$Y_3$	0.67	$Y_3$

### Static Equivalent Load

$$P_0 = F_r + Y_0 F_a$$

The values of  $e$ ,  $Y_2$ ,  $Y_3$  and  $Y_0$  are given in the table below.

Bearing Numbers	Abutment and Fillet Dimensions (mm)				Constant $e$	Axial Load Factors			Mass (kg) approx.
	$d_a$ min.	$D_b$ min.	$r_a$ max.	$r_b$ max.		$Y_2$	$Y_3$	$Y_0$	
206 KBE 2801+L	227	275	3	1.5	0.51	2.0	1.3	1.3	18.1
210 KBE 31+L	231	338	3	1.5	0.46	2.2	1.5	1.4	41.7
220 KBE 3001+L	238	292	2.5	1	0.37	2.7	1.8	1.8	21.2
220 KBE 30+L	241	324	3	1.5	0.40	2.5	1.7	1.6	27.9
220 KBE 030+L	241	327	3	1.5	0.40	2.5	1.7	1.6	34.7
220 KBE 31+L	247	345	4	1.5	0.39	2.6	1.7	1.7	48.3
220 KBE 031+L	247	349	4	1.5	0.39	2.6	1.7	1.7	60.2
220 KBE 42+L	247	371	4	1.5	0.40	2.5	1.7	1.6	74.2
240 KBE 30+L	261	344	3	1.5	0.39	2.6	1.7	1.7	30.1
240 KBE 030+L	261	344	3	1.5	0.35	2.9	2.0	1.9	37.3
240 KBE 31+L	267	380	4	1.5	0.43	2.3	1.6	1.5	60.0
240 KBE 031+L	267	378	4	1.5	0.39	2.6	1.7	1.7	73.6
240 KBE 4003+L	267	384	4	1.5	0.33	3.0	2.0	2.0	96.4
250 KBE 3801+L	271	365	3	1	0.40	2.5	1.7	1.6	35.5
260 KBE 30+L	287	379	4	1.5	0.40	2.5	1.7	1.6	43.4
260 KBE 030+L	287	382	4	1.5	0.40	2.5	1.7	1.6	54.1
260 KBE 31+L	287	416	4	1.5	0.39	2.6	1.7	1.7	82.5
260 KBE 4401+L	287	414	4	1.5	0.38	2.6	1.8	1.7	98.1
260 KBE 031+L	287	416	4	1.5	0.39	2.6	1.7	1.7	104.0